

# New Hampshire DOT

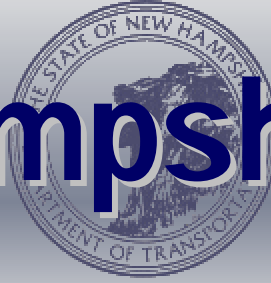

## Research Record



## Winter Tenting of Highway Pavements



Prepared in cooperation with the U.S. Army Corps of Engineers, Cold Regions Research and Engineering Laboratory, and the U.S. DOT, Federal Highway Administration

1. Report No. FHWA-NH-RD-12323C		2. Gov. Accession No.	3. Recipient's Catalog No.
4. Title and Subtitle <b>Winter Tenting of Highway Pavements;</b> Test Program and Discussion of Causes and Mechanisms		5. Report Date Oct 28, 2000	
		6. Performing Organization Code	
7. Author(s) Maureen A. Kestler, Audrey S. Krat, and Glenn E. Roberts		8. Performing Organization Report No.	
9. Performing Organization Name and Address US Army Cold Regions Research and Engineering Laboratory 72 Lyme Road Hanover, NH 03755-1290		10. Work Unit No. (TRAIS)	
		11. Contract or Grant No. 12323C, SPR-0004(6)	
12. Sponsoring Agency Name and Address New Hampshire Department of Transportation Bureau of Materials and Research Box 483, Stickney Avenue Concord, New Hampshire 03302-0483		13. Type of Report and Period Covered FINAL REPORT	
		14. Sponsoring Agency Code	
15. Supplementary Notes In cooperation with the U.S. DEPARTMENT OF TRANSPORTATION, FEDERAL HIGHWAY ADMINISTRATION			
16. Abstract <p>Tenting consists of localized frost heaving in the immediate vicinity of transverse pavement cracks. It produces a highly irregular riding surface, leads to premature pavement-surface deterioration, occurs on highways designed for high traffic volumes and to withstand freezing and thawing, and is frequently exhibited by pavements in otherwise good condition.</p> <p>The objective of the project discussed was to investigate causes and mechanics of the phenomenon. Several transverse cracks at four test sites were monitored for salt concentration, moisture content, subsurface temperature, freezing point depression, and heaving throughout several winter/spring seasons.</p> <p>Tenting on NH highways was determined to be a near-surface phenomenon caused by a complex combination of factors, with the underlying cause being intrusion of road salt-sand mix into the base course. Available water (meltwater and precipitation serving as a transport medium), cracked asphalt (providing a water entry point), salt-sand mix (for winter road maintenance), freeze-thaw cycling of the base course (due to temperature fluctuations and saline-induced freezing point depression), and the phase diagram of NaCl (salt coming out of solution as freezing occurs, thereby increasing salt concentration adjacent to the freezing front, increasing the freezing point depression even further) all appear to be necessary components for tenting to occur.</p>			
17. Key Words Tenting, lipping, heaving, frost heave, frost action, deicing salts, pavement cracks, pavements in cold regions		18. Distribution Statement No Restrictions. This document is available to the public through the National Technical Information Service (NTIS), Springfield, Virginia, 22161.	
19. Security Classif. (of this report) UNCLASSIFIED	20. Security Classif. (of this page) UNCLASSIFIED	21. No. of Pages	22. Price

# **Winter Tenting of Highway Pavements; Test Program and Discussion of Causes and Mechanisms**

for

New Hampshire  
Department of Transportation

by

Maureen A. Kestler <sup>1</sup>  
Audrey S. Krat <sup>2</sup>  
and  
Glenn E. Roberts <sup>3</sup>

April 1999  
Revised October 2000

---

<sup>1</sup> Research Civil Engineer, US Army Cold Regions Research and Engineering Laboratory, 72 Lyme Road, Hanover, NH 03755-1290, Tel: 603-646-4215, Fax: 603-646-4640, Email: mkestler@crrel.usace.army.mil

<sup>2</sup> Former Research Geologist, US Army Cold Regions Research and Engineering Laboratory, 72 Lyme Road, Hanover, NH 03755-1290, Tel: 603-646-4677, Fax: 603-646-4640, Email: akrat@crrel.usace.army.mil, current Email: audrey\_krat@hotmail.com

<sup>3</sup> Research Engineer, NH Department of Transportation, Bureau of Materials & Research, Concord, NH 03302 Tel: 603-271-1660, groberts@dot.state.nh.us

Prepared in cooperation with the New Hampshire Department of Transportation and the U.S. Department of Transportation, Federal Highway Administration.

The contents of this report reflect the views of the authors who are responsible for the facts and the accuracy of the data presented herein. The contents do not necessarily reflect the official views or policies of the New Hampshire Department of Transportation or the Federal Highway Administration at the time of publication. This report does not constitute a standard, specification, or regulation.

## TABLE OF CONTENTS

LIST OF FIGURES AND TABLES .....	5
ABSTRACT.....	6
INTRODUCTION.....	7
PROBLEM AND ITS OCCURRENCE .....	7
PHASE I.....	8
<b>Sites and Field Test Procedure</b> .....	8
<b>Phase I Observations</b> .....	9
PHASE II .....	10
<b>General</b> .....	10
<b>Discussion of Phase II</b> .....	11
DISCUSSION .....	11
<b>Freezing Process in the Presence of Road Salt</b> .....	11
<b>Salt Solution Phase Diagram</b> .....	12
<b>Summer Tenting</b> .....	12
<b>More on Tenting</b> .....	13
<b>Survey of Other DOTs and Geographical Occurrence of Tenting</b> .....	13
SUMMARY .....	14
RECOMMENDATIONS .....	15
ACKNOWLEDGMENTS .....	16
LITERATURE CITED .....	16

### FIGURES AND TABLES

**APPENDIX A:** Installation of Vitel Hydra Moisture Sensors, I-89, Northbound Lane

**APPENDIX B:** Vitel Hydra Soil Moisture Sensors (Radio Frequency Probes)

**APPENDIX C:** Progression of Tenting on I-89, 1995-1996 and 1996-1997 Winters

**APPENDIX D:** Salinity as a (Seemingly Random) Function of Distance from Crack

**APPENDIX E:** Results from Informal Survey of (Northern) State Departments of Transportation

## LIST OF FIGURES AND TABLES

### Figures

Figure 1. Tenting .....	19
Figure 2. Test site locations.....	19
Figure 3. Vertical displacement at Site 2 during the 1993-1994 winter.....	20
Figure 4. Surface of base course during pit excavation.....	21
Figure 5. Frost susceptibility chart .....	23
Figure 6. Vertical displacement at Site 4 during the 1996-1997 winter.....	23
Figure 7. Freezing process in the presence of salt.....	24
Figure 8. Phase diagram for sodium chloride.....	25

### Tables

Table 1. Frost design soil classification .....	26
---	----

## **ABSTRACT**

It is estimated that a pavement structure subjected to seasonal freezing has approximately 50% of the maintenance-free life of a similarly designed and constructed pavement structure in a non-frost area. Differential frost heaving during the winter and early spring, and loss of pavement strength during thawing, result in a variety of pavement distresses including cracking and rutting. These distresses have received considerable attention in the literature. In contrast, “tenting” has received only minimal attention.

Tenting consists of localized heaving in the immediate vicinity of transverse pavement cracks. It typically produces a highly irregular riding surface, particularly toward the end of the winter season, and can lead to rapid premature deterioration of the pavement surface. There have been unofficial estimates of as much as 10 cm (4 in.) of rise over a horizontal distance of approximately 3.3 m (10 ft). In contrast to most frost related distresses, tenting is not unique to low volume roads; it occurs just as frequently on highways that have been designed for high volumes of traffic and to withstand freezing and thaw weakening. Furthermore, it is frequently exhibited by pavements that are in otherwise good condition.

Because the distribution of salinity (from road salt) within the base course is suspected to be a primary contributor toward tenting, about a dozen transverse cracks in New Hampshire were monitored throughout several winter/spring seasons. Sensors were installed to monitor salt concentration, moisture content, subsurface temperature, and freezing point depression at one crack, and more limited instrumentation was installed at several other cracks. Pavement elevation surveys were conducted throughout the freeze-season to monitor tent formation. At the end of the winter, arrays of base course samples were collected immediately beneath and adjacent to several of the cracks for subsequent laboratory analysis.

Most frost related distresses can be attributed to the underlying subgrade, or to contamination of the gravel base with subgrade material. However, based upon observed correlations between frost/thaw penetration and tenting progression, tenting on NH highways was determined to be a near-surface phenomenon. Furthermore, it was determined to be caused by a complex combination of factors, with the underlying cause being intrusion of road salt-sand mix into the base course. Available water (meltwater and precipitation serving as a transport medium), cracked asphalt (providing a point of entry for water into the pavement system), salt-sand mix (used for winter road maintenance), freeze-thaw cycling of the base course (due to both temperature fluctuations and saline-induced freezing point depression), and the phase diagram of NaCl (salt coming out of solution as freezing occurs, thereby increasing salt concentration adjacent to the freezing front, increasing the freezing point depression even further) all appear to be necessary components for tenting to occur.

A 1998 ASCE Cold Regions Specialty Conference paper (Kestler et al. 1998) outlines the test program, discusses results from field testing, and theorizes the causes and mechanics of tenting. The following report, prepared for the NHDOT, both incorporates and expands upon the conference paper, and provides a sequel to the 1995 winter tenting report provided for NHDOT (Kestler and Berg 1995).

## **INTRODUCTION**

Localized heaving in the immediate vicinity of transverse pavement cracks has been termed tenting, or lipping (Figure 1). This phenomenon has been observed on numerous roads throughout New Hampshire, however, it is not unique to this state. Although tenting may occur to a lesser degree throughout the year, it typically produces a highly irregular riding surface toward the end of the winter season. Tenting is typically more severe in the passing lane and along the shoulders than in the driving lane. Although maximum tenting measured during the NHDOT research program was in slight excess of 3 cm (1 in.), there have been unofficial reports of as much as 10 cm (4 in.) of vertical rise over a horizontal distance of approximately 3.3 m (10 ft). Of perhaps greatest significance is that tenting is frequently exhibited by pavements that are in otherwise good condition, i.e., pavements that exhibit neither extensive rutting nor fatigue cracking. Additionally, tenting does not necessarily occur each year. It is often particularly severe one year, and negligible the following year.

Following a winter of severe tenting, the New Hampshire Department of Transportation (NHDOT) employed the efforts of the US Army Cold Regions Research and Engineering Laboratory (CRREL) in Hanover, NH in 1993 to investigate the causes and mechanics of the phenomenon. Monitoring was conducted in two phases. The sites selected for observation during Phase I were known to have exhibited substantial tenting in preceding years. Because results from Phase I were not fully conclusive (Kestler and Berg 1995), a more comprehensive Phase II investigation was launched. Phase II included more frequent pavement surface elevation surveys, subsurface instrumentation (not included in Phase I), and a focus on salinity from road salt. The following report describes Phase I and II test programs and observations, then provides a discussion of probable mechanisms and recommendations for future work. Although it was concluded that salinity from sand-salt mixes (used for winter highway maintenance) is the primary cause of the phenomenon, preliminary thoughts throughout both phases are discussed and the thought process outlined through development.

## **PROBLEM AND ITS OCCURRENCE**

Other than thermal cracking, most frost related distresses can be directly or indirectly attributed to the subgrade or to dirty base course material. However, this was not the case for tenting as was observed in NH. Correlations between occurrence of tenting and frost penetration indicate that tenting is a near-surface phenomenon (related to the road salt-



sand mix getting into the base course material). In contrast to conventional frost heaving that occurs when frost reaches the frost susceptible subgrade, tenting occurs while the frost is contained within the upper reaches of the pavement structure when frost doesn't even get near frost susceptible material, whether that be the subgrade or base course with fines that might have migrated up. It should, however, be noted that one study in central Canada did correlate tenting to the subgrade. Undoubtedly, it is a complex phenomenon, and can have many contributing factors.

Tenting has also been observed more frequently in longitudinal slope sections where salt-rich surface water flow is intercepted by transverse cracks than on level road sections. Longitudinal cracks also intercept surface water, but the drainage area is appreciably smaller, and this is reflected in the reduced occurrence and magnitude of tenting observed along longitudinal cracks.

Regarding geographical occurrence, informal telephone discussions were conducted with representatives from several State Departments of Transportation. Survey results will be discussed later in this report.

## **PHASE I**

### **Sites and Field Test Procedure**

In an attempt to identify the causes and mechanics of tenting, cracks at two locations were initially selected for observation and testing: the Hanover-bound lane of Route 120 in Lebanon, NH (Site 1), and the north-bound passing lane of Interstate 93 (I-93) immediately north of exit 29 in Thornton, NH (Site 2) (Figure 2). The proposed plan was to excavate a test pit and collect soil samples immediately beneath the crack in the hot mix asphalt (HMA) and in the material immediately adjacent to the crack at each of the two test sites. Samples were scheduled to be collected in the fall, pavement elevation surveys conducted throughout the winter, and a second test pit excavated with samples collected at each test site near the end of the winter, when tenting is typically at its maximum.

During the fall of 1993, 1.3 x 1.3 x .8 m deep (4 x 4 x 2-1/2 ft deep) test pits were excavated at one of two adjacent cracks selected for testing and monitoring at both locations. Nuclear density and sand cone tests were conducted in each of the test pits to determine in-place density. Subsequent laboratory tests conducted on the samples included moisture contents, sieve and hydrometer analyses, and conductivity tests to determine salt content.

Pavement surface elevation surveys were periodically conducted at Site 1 throughout the 1993-1994 and 1994-1995 winter to monitor the magnitude of the tenting phenomenon. Minor tenting was observed. However, an asphalt overlay was placed over the test site

during the summer of 1995, and further monitoring of surface elevations was discontinued.

Pavement elevation surveys were also conducted at Site 2 during the 1993-1994 winter. The magnitude of tenting was minimal, nevertheless a second test pit was excavated in March 1994, in-situ tests were conducted, and base course samples were collected for laboratory analysis.

## **Phase I Observations**

*General:* Phase I observations are briefly summarized in the following section. Additional photos, discussion, and associated graphs and data are provided in a report by Kestler and Berg (1995) prepared for NHDOT.

*Elevation Surveys:* Vertical displacements for Site 2 during the 1993-1994 winter are shown in Figure 3. The magnitude of tenting was approximately 3 cm (1.2 in.). Peaking at the crack was unquestionable.

Vertical displacement immediately adjacent to the crack at Site 2 occurred during late fall and early winter when the pavement experienced multiple freeze-thaw cycles. In contrast, additional displacement during the month of February, which had only one thaw, was uniform along the entire 9.8 m (30 ft) long survey line. The additional uniform heave most likely resulted from conventional frost heaving as frost penetrated deeper into the pavement section. This indicated a possible correlation between tenting and some factor, or combination of factors, such as freeze-thaw cycles or available water (a possible transport medium), or the salt transported by the water. Unfortunately, surface elevation surveys were not conducted frequently enough, nor were near-surface pavement temperatures being monitored, thus conclusions could not be drawn.

*Test pit excavation:* Transverse pavement cracks, test pit markings, and a pavement surface elevation survey grid at Site 1, but typical of all test sites, is shown in Figure 4a. Test pit excavation necessitated removal of the 11 and 23 cm (4 and 9 in.) thick HMA layers at Sites 1 and 2, respectively, with minimal disturbance to the surface of the underlying base course. The surface of the base course at Site 1 immediately following HMA removal during the first pit excavation is shown in Figure 4b. A well-defined ridge-line conforming to the path of the crack was exposed. Observations resulting from the pit excavation follow discussion of frost susceptible soils:

Casagrande (1938) found that frost susceptibility could be expressed as an empirical function of grain size. This is still accepted today. Generally, soils with 3 or more percent (by weight) finer than .02 mm are frost susceptible. Gravel with 1-1/2 to 3% finer than .02 mm may be frost susceptible. Uniform sandy soils can, however, have up to 10% by weight finer than .02 mm without being frost susceptible. Figure 5 and Table 1

(TM 5-818-2/AFM 88-6, chap 4) show average rates of heave for gravels, sands, silts and clays and frost design soil classifications, respectively.

Sieve and hydrometer analyses for base course samples close to the crack at Site 2 fell within the low to medium range for frost susceptibility. While most samples from Site 1 ranged from 3.3 to 4.9% finer than .02 mm, two samples exhibited very high percentages --11.2% and 17.9%. These corresponded to extremely high percentages (30+/-%) passing the No 200 sieve. These two samples were taken from the ridge-line of very fine material immediately beneath and filling the lower reaches of the crack within the HMA discussed above (Figure 4). This material was appreciably more frost susceptible than the base course. It is possible that this is the result of fines being washed into the crack from road salt-sand mix, plus degradation of the HMA at the crack. Although ridge-line material might account for heave in the immediate vicinity of the crack, the quantity of material composing this ridge is relatively small. It might be a contributor toward tenting, but cannot explain tenting in itself.

No density or salinity trends were detected. However, as discussed above, elevation surveys at one site, in combination with local environmental conditions (air and estimated surface temperatures (Berg draft)), indicated that tenting *might* be related to freeze-thaw cycling and road salt. The salt is transported by available water from snow-melt or rain and surface/near-surface freeze-thaw cycles. These cycles occur at varying temperatures and varying distances from the crack because of road salt induced freezing point depression. Because information was insufficient from Phase I, an extended, more comprehensive Phase II study was recommended and launched.

## **PHASE II**

### **General**

Transverse crack sites selected for Phase II monitoring are shown in Figure 2. Monitoring sites include two transverse cracks on the westbound lane of Route 112 in North Woodstock, NH (Site 3), and several transverse cracks on Interstate 89 (I-89) near the Sutton/Warner town line, NH (Sites 4a-c). Sites 4a and b (including a few cracks each) are located on the south-bound passing lane, and site 4c is located on the northbound passing lane.

In 1996, Sites 3 and 4 were instrumented with thermistors to monitor subsurface temperatures. Additionally, site 4c was instrumented with Vitel hydra soil moisture sensors (Vitel 1994, Kestler et al. 1999, Kestler et al. 1997, and Kestler et al. draft) to monitor subsurface moisture, salinity, temperature, and freezing point depression. A brief construction report and corresponding plan and profile of Vitel hydra soil moisture sensors are provided in Appendix A. Appendix B provides additional information on the Vitel hydra soil moisture sensor as well as sketches/photos of the soil moisture sensor. A Campbell datalogger recorded both thermistor and Vitel data a few times daily. Test pits

were excavated at sites 3 and 4c at the end of the 1996-1997 freeze season, and pavement elevation surveys were conducted approximately every other week.

## **Discussion of Phase II**

*Surface manifestation:* Site 4 pavement elevations through the 1996-1997 winter are shown in Figure 6. Maximum vertical displacement was 1.5 cm (0.6 in). While the magnitude of heave is lower than values observed in the past, data show nearly an order of magnitude more displacement immediately adjacent to the crack than at distances over 2 m (6.6 ft) away. This clearly indicates heave activity by some winter-related phenomenon. Appendix C provides figures showing progression of tenting at each of the site 4 cracks (labeled as 4c northbound, 4c[2] northbound, 4b [a series of cracks on the southbound lane], 4a[1] southbound, and 4a[2] southbound) throughout the 1995-1996 and 1996-1997 winters. Note that the cracks on the southbound lane of I-89 had been sealed with a crack sealer. The magnitude of tenting was slightly less than open cracks. However, it is assumed that some salt still remained in the base course in the vicinity of the crack from before the cracks were sealed, and also that additional salt infiltrated into the cracks where the crack was not perfectly sealed.

*Salinity:* Salinities of base course samples collected during the 1997 springtime test pit excavation provided information about salt concentration that was believed would enable correlations between salinity-induced freezing point depression and vertical displacement over time. Salt concentration was significantly less at substantial vertical and horizontal distances from the HMA crack, as would be expected for contaminant flow. However, concentration was not a simple function of distance from the crack. Results from laboratory testing indicated seemingly random fluctuations in salt content with increasing distance from the crack (Appendix D). This pattern, or rather lack of, was an indicator of the complex history of freezing and thawing of the salt contaminated base course material at varying temperatures and varying vertical and horizontal distances from the HMA crack. Additionally, salt application rate varied thereby causing an additional fluctuation. Laboratory testing in which temperature and application rate of salt are controlled would be necessary to separate variables and detect salinity patterns.

## **DISCUSSION**

### **Freezing Process in the Presence of Road Salt**

The following is based on Shober's work (1971). Subsurface temperatures, frozen/non-frozen ground conditions, and salinities from the NH field test sites conform to such rationale: Figures 7a-d are a simplification of a figure provided by Shober: Curves on the left side show subsurface temperature gradients as freezing and thawing occur. Progressive cross sections of the soil are provided on the right. Figure 7a shows an initial freezing gradient (left) and corresponding state of ground (right). Then assume a thaw

sets in. The new freezing gradient and corresponding state of ground are shown in Figure 7b. Figure 7b (right) also shows a superimposed salinity concentration at time t, after the salt-laden surface water (carrying the salt-sand mix) enters into the crack in the pavement surface, and infiltrates into the thawed base course. Now assume another freeze cycle. The progressive freezing gradient and state of ground are shown in Figure 7c. Note, because of the presence of salt and the associated freezing point depression, the soil no longer freezes uniformly downward and perpendicular to the temperature gradient. Rather the freezing front proceeds in a non-linear fashion with different regions of base course freezing at different temperatures as shown by hashed shading. Figure 7d shows temperature gradient and state of ground as freezing continues. If freezing were to occur from the surface downward, as in the absence of a freezing point depressing agent, the source of water would be cut off from the crack, and the tenting process could not occur. However, in the presence of this ongoing water source, small ice lenses, which are responsible for heaving (or, in this case, tenting because it occurs only at the crack), accumulate at the freezing front.

### **Salt Solution Phase Diagram**

To add yet additional complexity to the above process, consider the phase diagram for salt brine (Figure 8). When salt solutions of less than 23.3% freeze, pure ice freezes out leaving saturated brine. Consequently, the highest concentration salt solution (which occurs at the entrance to the crack) will not remain the highest, but rather be at a lower concentration than the saturated brine that remains as the salt solution freezes. This becomes more complicated as the salt solution dissipates through unfrozen soil to areas of lower salt concentration while air and surface temperatures change. Based upon both the phase diagram and the manner in which a salt contaminated base course freezes (as air temperatures fluctuates and freezing point depression governs freezing), it is not difficult to understand why salt content can fluctuate without any definitive pattern as was the case in samples tested following pit excavations (Appendix D).

### **Summer Tenting**

The following theorizes why tenting does not always fully disappear during the summer: In the presence of fluctuating air temperatures and changing concentrations of road salt through repeated application for snow and ice control, the HMA to either side of the crack is lifted by ice pressure. Sand from the road salt-sand mix continually enters the crack as thaw cycles occur. This exacerbates the localized heaving problem if the salt-sand mix for ice control has a high percentage of fines. This also increases the amount of material, as well as the frost susceptibility of sand immediately beneath the HMA crack.

- 1) This could explain the higher percentages of fines in the immediate vicinity of the crack during pit excavations.

- 2) It could also explain why tenting is generally worse in the passing lane and shoulder than in the travel lane. Constant traffic may accelerate/hasten settling and conformance of the HMA slab to underlying base course before sand can make its way into any void between the HMA and base course at the crack.
- 3) Finally, it could explain why tenting does not always completely disappear during the summer.

### **More on Tenting**

Taking these theories yet a step further, an independent, similar study is also being conducted in Quebec, Canada, where some highways exhibit as much as 70 mm (3 in.) tenting by the end of a typical winter. Dore et al. (1997) hypothesized that:

- 1) Salt concentration gradient and the resulting freezing point depression gradient can take the place of thermal gradient (Konrad and Morgenstern 1980) required for ice segregation (i.e., frost heaving) to occur in salt free frost susceptible soils (in full conformance with above theories), and
- 2) Salt concentration gradient can also contribute to increasing frost susceptibility of non frost susceptible granular materials.

Dore and others (Dore et al. 1997) isothermally cooled 76 mm (3 in.) diameter cylindrical samples of both salt free material and material comprising layers of increasing salinity control. Salt free control samples showed no heaving, yet samples with saline gradients exhibited maximum heave rates of 6 mm (0.24 in.) per day. This *proved* that salt concentration gradient and the resulting freezing point depression gradient can take the place of thermal gradient required for ice segregation to occur in salt free soils.

While Phase II observations do not specifically address the above hypotheses, i.e., controlled laboratory conditions would have been necessary, observations unquestionably support them. It is believed that the Dore et al. hypotheses and lab test results *combined* with additional theories on the salt-sand mix entering the crack during localized thawing (also caused by the salt having lowered the freezing point depression) developed during NHDOT/CRREL Phase I and II could provide the explanation of the complex mechanisms responsible for tenting.

### **Survey of Other DOTs and Geographical Occurrence of Tenting**

Conversations with representatives from State, Federal, and private agencies and organizations in northern United States, Canada, and northern Europe indicate tenting occurs in some seasonal frost areas, yet seemingly not in others. A telephone survey was conducted of state DOTs to determine which states experience, or do not experience, winter pavement tenting, and what these states have in common; e.g., type of road salt (Sodium Chloride, Potassium Chloride, etc.), typical road salt application rates, typical

gradation of sand in road salt-sand mix, specified base course gradation, etc. The specific questions and responses are provided in Appendix E. Most northern states responded that they did not have problems with tenting. However, Quebec and Minnesota report they have, at times and particular locations, observed severe tenting. Tenting in Minnesota has been so severe that they are considering follow-up research. Tenting has also been observed in Vermont, Maine, Wisconsin, and West Virginia. Unfortunately, information necessary to determine what factor tenting states (and provinces) had in common with each other, and not with non-tenting states, was not available, so we cannot look toward this information as an aid in recommending preventive measures. One important piece of information that was simply not available from State DOTs without further testing is the grain size distribution of hydrometer size particles for the road salt-sand mix. Nor is information on grain size distribution as a result of wear of particles available. As discussed earlier, percent of particles smaller than .02 mm (detectable only by hydrometer testing) is correlated to frost susceptibility. However, specifications for road sand never refer to particle sizes that require hydrometer testing.

It is believed that tenting has also been observed in states that responded negatively to the survey, but the particular survey recipient was unaware of tenting. It should be noted that informal conversations with USDA Forest Service representatives indicate that significant tenting has been observed in localized areas of Michigan, but not in others. It is believed that this can be attributed to the higher salt use in regions that have observed tenting. Other unofficial observations have been reported in Montana and Massachusetts. Many states that experience tenting simply attribute it to water getting into the cracks.

## **SUMMARY**

To identify the causes and mechanics of winter tenting, Phase I test pits were excavated and samples collected at two sites where transverse pavement cracks had exhibited tenting in past years. A ridge-line of very fine, highly frost susceptible material was exposed during pit excavation at both sites atop the base course, conforming to the path of each crack. This fine material, plus Phase I pavement elevation surveys hinted that near-surface freeze-thaw cycles and available water (including free water or water in unfrozen soil serving as a transport medium of salt) might be correlated to tenting.

A more comprehensive Phase II test program was launched that included bi-weekly pavement surface elevation surveys and subsurface instrumentation to monitor subsurface temperature, moisture, salinity and freezing point depression. Additionally, large arrays of base course samples were collected from pit excavations and tested for salinity. Elevation surveys showed nearly an order of magnitude greater vertical displacement in the immediate vicinity of the crack than just 2 m (6.6 ft) to either side.

Observations from the two phase test program on a dozen pavement cracks throughout New Hampshire along with ongoing laboratory testing by Dore et al. in Quebec enabled theories on the causes and mechanism behind tenting to be strengthened. In contrast to

most frost related distresses that can be directly or indirectly attributed to subgrade concerns, it was concluded that tenting observed in NH is a near-surface phenomenon. Once the frost reaches an appreciable depth as determined by thermistors and other temperature sensors, water migration from a water table or lower moist material is sealed off, and the crack in the HMA provides the only point of entry for water into the pavement system. Tenting is believed to be the result of salt-contaminated base course undergoing freezing in a non-uniform manner as this plentiful localized water source continues to provide water.

When winter highway maintenance salt-sand mixes are applied to cracked pavements, frost penetration does not progress vertically and uniformly into the pavement system. Rather it progresses non-linearly and at varying lower temperatures than in nearby non-salt-contaminated base material. If material of a higher salt concentration is near the crack, material very close to the crack will remain unfrozen because of the freezing point depression, and the crack allows additional water to enter the system. Thus, freezing and thawing of material near the crack is governed by salt content/gradient. Aggravating the situation, fine grain material from the road salt-sand mix also gets washed into the open crack. The base course immediately adjacent to the crack material undergoes freeze thaw cycling at temperatures different than the uncracked pavement. At the same time, salt concentration in that vicinity continually changes as additional road salt is distributed for snow and ice control as well as from saturated brine coming out of solution right at the freezing front. When freezing does occur, the frost susceptible sand that infiltrated into the crack heaves, then the system undergoes thaw consolidation. Additional road sand can continue to enter through the HMA crack before traffic causes the HMA slab to settle and conform to the underlying base course. This can explain the higher percentage of fines in the immediate vicinity of the crack during pit excavations, why tenting is generally worse in the passing lane and shoulder than in the travel lane, and why tenting does not always completely disappear during the summer months. The heaving of an otherwise non-frost susceptible base course material can be further explained by the work done by Dore et al (Dore et al. 1997) which showed that salt concentration gradient and the resulting freezing point depression gradient can take the place of thermal gradient required for ice segregation to occur in salt free frost susceptible soils.

## **RECOMMENDATIONS**

Conversations with representatives from State, Federal, and private agencies and organizations in northern United States, Canada, and northern Europe indicate tenting occurs in some seasonal frost areas, yet seemingly not in others. A more comprehensive written survey should be distributed to better determine which locations experience, or do not experience, winter pavement tenting. Questions should be similar to those of the informal telephone conversations, i.e., what factors states with tenting have in common; type of road salt (Sodium Chloride, Potassium Chloride, etc.), typical road salt concentrations, typical gradation of sand in road salt-sand mix (both original and some representative post trafficking gradations to account for wear), and specified base course



gradation, etc. Additionally, hydrometer analyses should be conducted on samples of material used in each state to estimate frost susceptibility.

Additional laboratory testing, which enables isolation of variables, should be conducted to determine salinity gradients, soil gradations, and combinations of the two that maximize and minimize salinity-gradient-driven heaving.

For tenting pavements, mitigating measures include removal and replacement of salt-contaminated base course or mixing/grading salt-contaminated base course, then re-surfacing. Alternately, crack sealing and overlays at least prevent *additional* salt water intrusion. However, when pavements are overlaid, reflection cracking often occurs, and the cycle of intrusion of road salt into cracks continues.

## **ACKNOWLEDGMENTS**

We wish to acknowledge the NH Department of Transportation, particularly Alan Rawson, Hiram Morrill, Alan Perkins, Ken Cogswell, Alan Hanscom, Ken Kyle, and Deb Loiselle for their support and assistance. We also thank Dick Berg, Dale Bull, Keith Stebbings, Charlie Smith, Tom Knight, Rosa Affleck, Sherri Orchino, Alan Ricard, Chris Berini, Amy Jacobson, and Carol Morgan (CRREL or formerly CRREL).

## **LITERATURE CITED**

Berg, Richard L. (draft) *A New Method for Estimating Surface Temperatures, Presented at the 4<sup>th</sup> International Symposium on Thermal Engineering and Science for Cold Climates*, 1993, US Army Cold Regions Research and Engineering Laboratory, Hanover, NH.

Campbell, Jeffrey Earle (1988) *Dielectric Properties of Moist Soil at RF and Microwave Frequencies*, Dartmouth College, Hanover, NH, September.

Casagrande, A (1938) *Effects of Frost in Soil*, Proceedings - 8<sup>th</sup> Congress, Permanent International Association of Road Congresses.

Departments of the Army and the Air Force (1985) *Pavement Design for Seasonal Frost Conditions ARMY TM 5-818-2, AIR FORCE AFM 88-6, Chapter 4*.

Dore, Guy, Jean-Marie Konrad and Marius Roy (1997) *The Role of Deicing Salt in Pavement Deterioration by Frost Action*, 76<sup>th</sup> Transportation Research Board Meeting, Washington, D.C.

Kaya, Abidin, C.W. Lovell and A.G. Altschaeffl, (1994) ***The Effective Use of Time Domain Reflectometry (TDR) in Geotechnical Engineering***, Proceedings - Symposium & Workshop on Time Domain Reflectometry in Environmental, Infrastructure, and Mining Applications, pp. 398-409, Northwestern University, Evanston, Illinois, September.

Kestler, Maureen A., Dale C. Bull, Brenda Wright, Gordon Hanek, and Mark Truebe (1997) ***Freeze-Thaw Testing of Time Domain Reflectometry and Radio Frequency Moisture Sensors***, Seasonally Frozen Soils Symposium, Fairbanks, AK, June.

Kestler, Maureen A., Gordon Hanek, Mark Truebe, Peter Bolander (1999) ***Removing Spring Thaw Load Restrictions from Low Volume Roads, Development of a Reliable Cost-Effective Method***, Transportation Research Board Low Volume Roads Conference, May.

Kestler, Maureen A., Jeffrey Stark, Major Bruce Gwilliam, Audrey S. Krat, and Thomas Knight, (draft) ***Field Deployable Soil Moisture Probe for Mobility Predictions***, Concept Evaluation Program report submitted to the US Army Engineer School, Dec 1997, CRREL Special Report undergoing review.

Kestler, Maureen A. and Richard L. Berg (1995) ***Determination of Causes and Mechanics of Winter Tenting or Lipping of Highway Pavements***, Unpublished report submitted to NH Department of Transportation.

Konrad, J.M. and N.R. Morgenstern (1980) ***A Mechanistic Theory of Ice Lens Formation in Fine Grained Soils***, Canadian Geotechnical Journal, Vol 17.

Roth, Kurt, Rainer Schulin, Hannes Fluhler, and Werner Attinger (1990) ***Calibration of Time Domain Reflectometry for Water Content Measurement Using a Composite Dielectric Approach***, Water Resources Research, Vol. 26, No.10, pp. 2267-2273, October.

Schofield, T.G., G.J. Langhorst, G. Trujillo, K. V. Bostick, W.R. Hansen, ***Comparison of Neutron Probe and Time Domain Reflectometry Techniques of Soil Moisture Analysis*** (1994) Proceedings - Symposium & Workshop on Time Domain Reflectometry in Environmental, Infrastructure, and Mining Applications, pp. 130-142, Northwestern University, Evanston, Illinois. September.

Shober, Stephen (1971) ***Frost Tenting***, Wisconsin Department of Transportation.

Topp, G.C., S.J. Zegelin, and I. White (1994) ***Monitoring Soil Water Content Using TDR: An overview of Progress***, Proceedings - Symposium & Workshop on Time Domain Reflectometry in Environmental, Infrastructure, and Mining Applications, pp. 67-80, Northwestern University, Evanston, Illinois. September.

Vitel (1994) *Hydra Soil Moisture Probe User's Manual, Version 1.1*, Chantilly, VA, February.

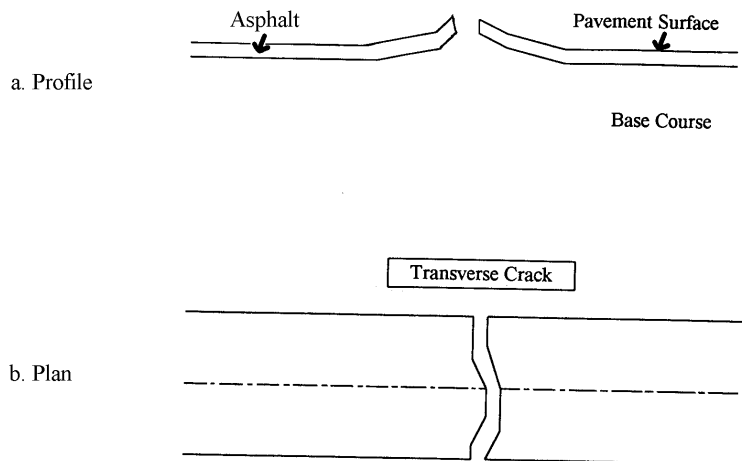

Figure 1. Tenting.

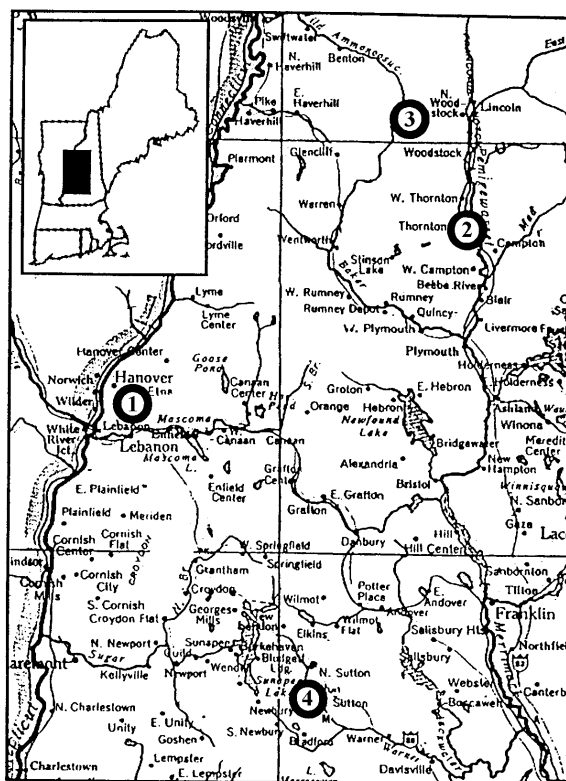

Figure 2. Test site locations.

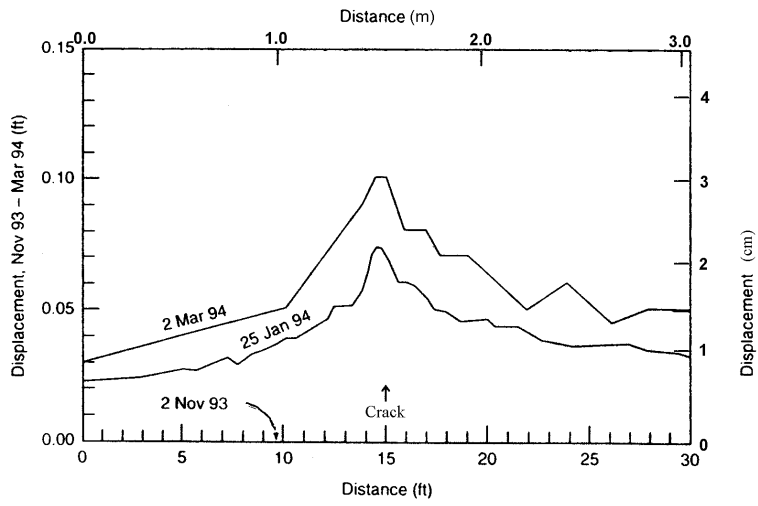

Figure 3. Vertical displacement at Site 2 during the 1993-1994 winter.



- a. Site 1 – transverse cracks and surface elevation grid (longer than typical 30 ft grid).

Figure 4. Test site and excavation pit.



b. Site 1 – surface of base course during pit excavation.

Figure 4. Test site and excavation pit.

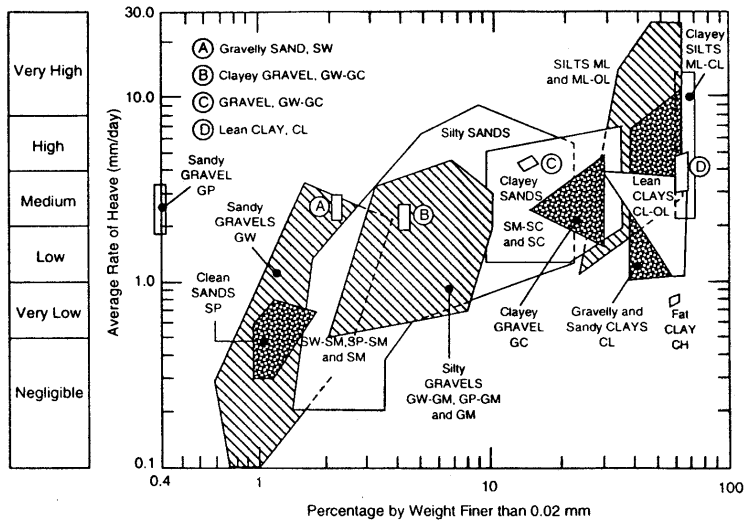

Figure 5. Frost susceptibility chart.

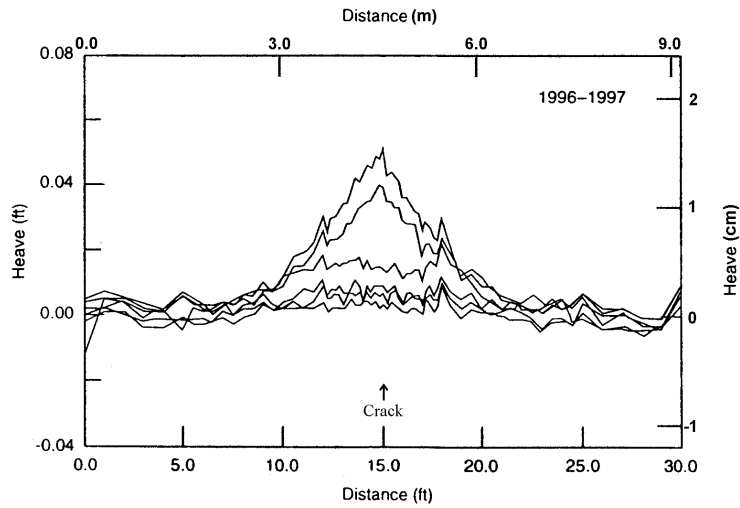

Figure 6. Vertical displacement at Site 4 during the 1966-1997 winter.



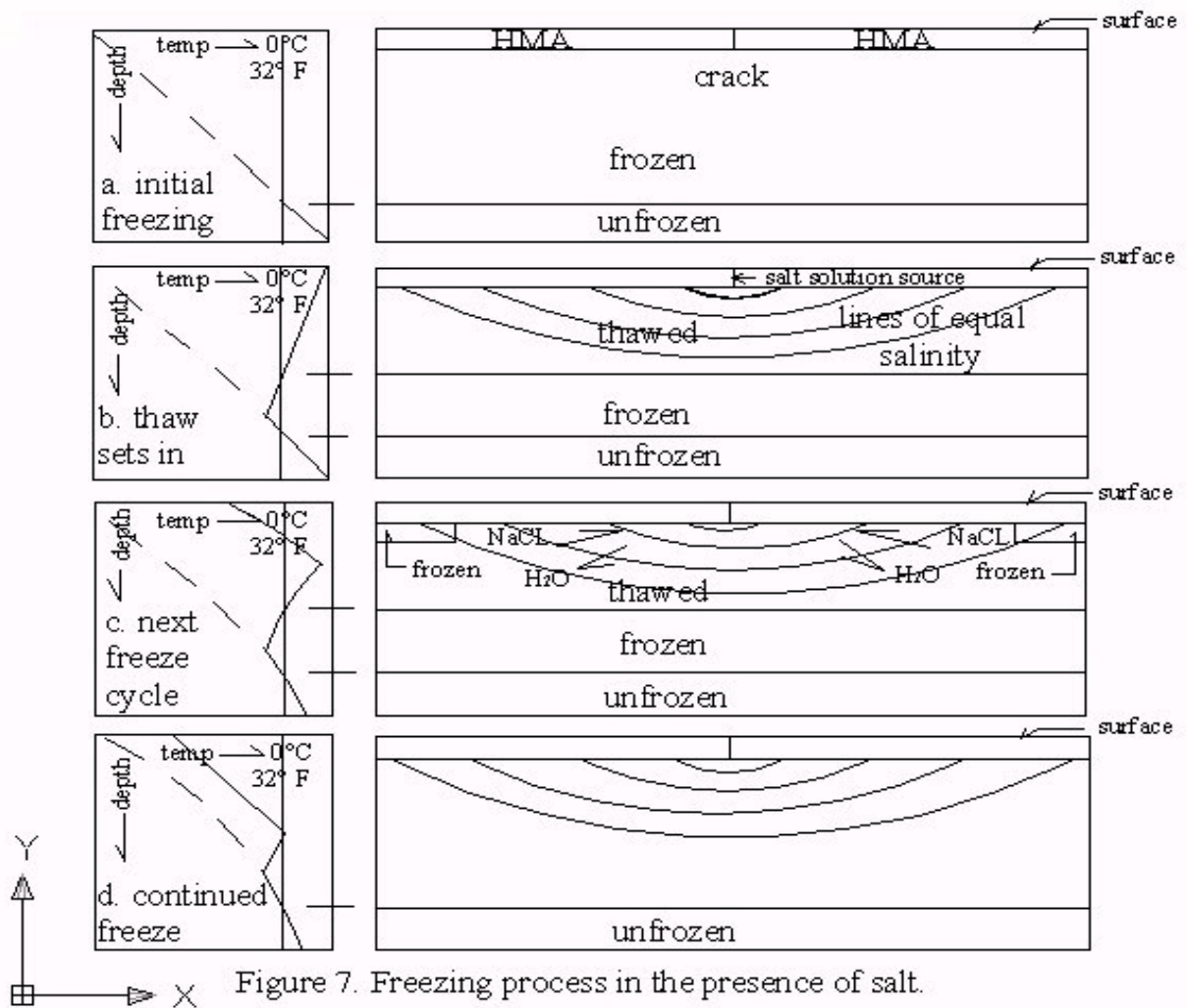

Figure 7. Freezing process in the presence of salt.

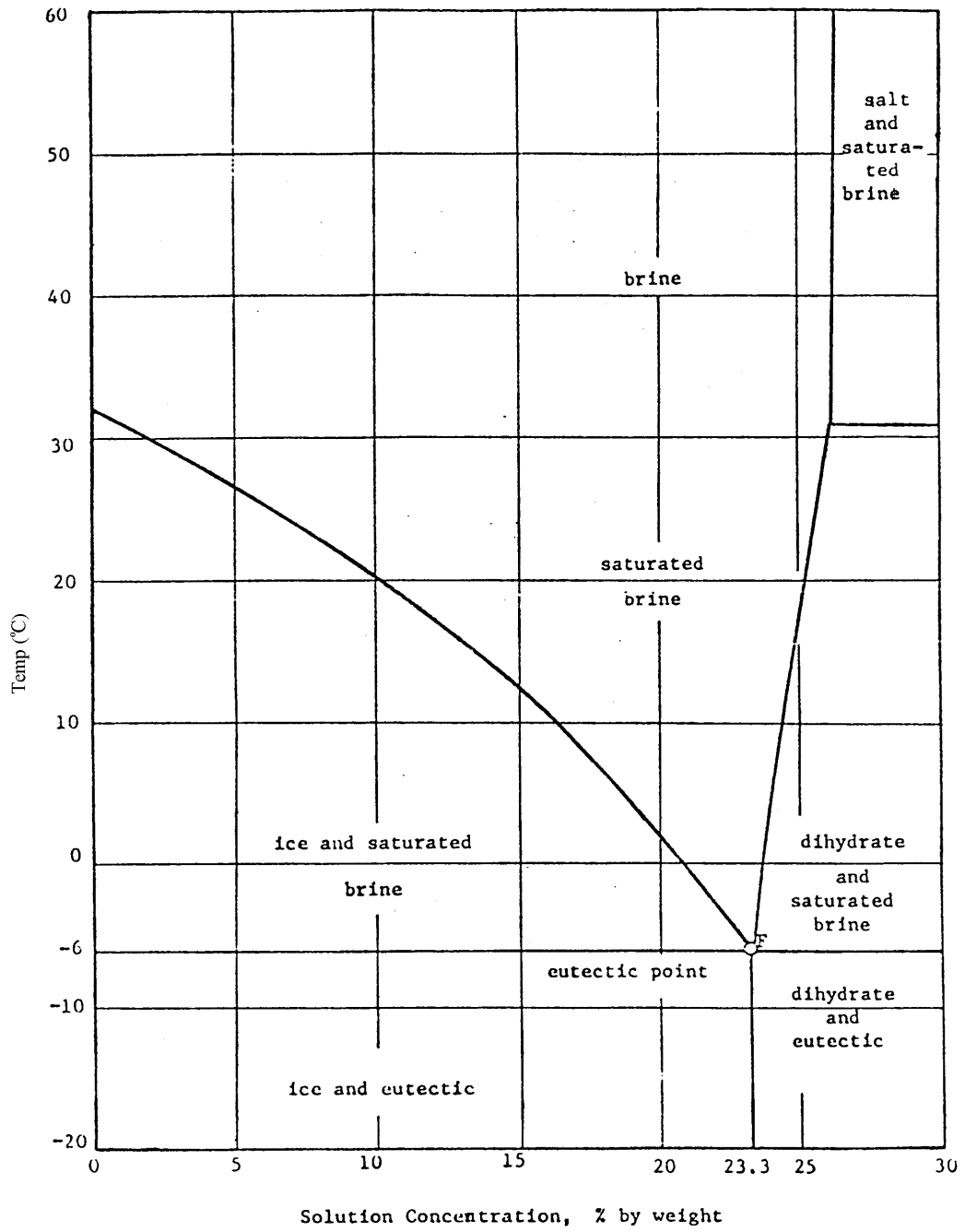

Figure 8. Phase diagram for sodium chloride and water. (Shober 1971).

**Table 1. Frost design soil classification.**

<i>Frost group</i>	<i>Kind of Soil</i>	<i>Percentage finer than 0.02 mm by weight</i>	<i>Typical soil types under Unified Soil Classification System</i>
NSF**	(a) Gravels	0-1.5	GW, GP
	Crushed stone Crushed rock		
PFS†	(b) Sands	0-3	SW, SP
	(a) Gravels	1.5-3	GW, GP
	Crushed stone Crushed rock		
S1	(b) Sands	3-10	SW, SP
	Gravelly soils	3-6	GW, GP, GW-GM, GP-GM
S2	Sandy soils	3-6	SW, SP, SW-SM, SP-SM
F1	Gravelly soils	6-10	GM, GW-GM, GP-GM
F2	(a) Gravelly soils	10-20	GM, GW-GM, GP-GM
	(b) Sands	6-15	SM, SW-SM, SP-SM
F3	(a) Gravelly soils	Over 20	GM, GC
	(b) Sands, except very fine silty sands	Over 15	SM, SC
F4	(c) Clays, PI > 12	—	CL, CH
	(a) All silts	—	ML, MH
	(b) Very fine silty sands	Over 15	SM
	(c) Clays, PI > 12	—	CL, CL-ML
	(d) Varved clays and other fine-grained, banded sediments	—	CL, CL-ML CL and ML CL, ML, and SM CL, CH, and ML CL, CH, ML and SM

\*\*Non-frost-susceptible.

†Possibly frost-susceptible, but requires laboratory test to determine frost design soils classification.  
U.S. Army Corps of Engineers

## **Appendix A**

### **Installation of Vitel Hydra Moisture Sensors, I-89, Northbound Lane Construction Report, Plan, and Profile**

#### Instrumentation Installed in I-89 Northbound Lane Test Pit on December 20, 1996

On December 20 1996, representatives from the Cold Regions Research and Engineering Laboratory (CRREL) and the New Hampshire Department of Transportation (NHDOT) met onsite to excavate a test pit and install instrumentation on the north-bound lane of Interstate 89 (I-89). The test pit was drilled at a crack in the passing lane which had been previously selected for testing and monitoring based on observed tenting. The sealer used to initially close the crack was removed before drilling began. A Mobile B-53 Drill Rig was used to excavate the pit - a series of four 8 inch overlapping circular borings approximately 4 feet deep (Figure A-1). A monitoring boring was also drilled 18.1 feet north of the crack, connected by a wide saw cut.

14 radio frequency probes (RF probe) were installed in the test pit to monitor moisture and salinity in the base over time. One RF probe was placed in the control boring located 18 feet north from the crack. An elevation survey was taken at each RF probe placement. The probes were arranged along the length of the pit ranging 0 to 14 inches from the crack, and at different elevations ranging 9.3 to 46.6 inches from the pavement surface (Figure A2). A Campbell Datalogger will record the moisture, temp, & salinity twice a day and be downloaded weekly. By measuring the moisture concentration in the soil and conducting pavement elevation surveys, a relationship among salinity, temp, moisture, freeze-thaw cycles, and tenting is to be determined.

FIG A-1  
 Plan View - 189 Northbound Lane Warner, NH

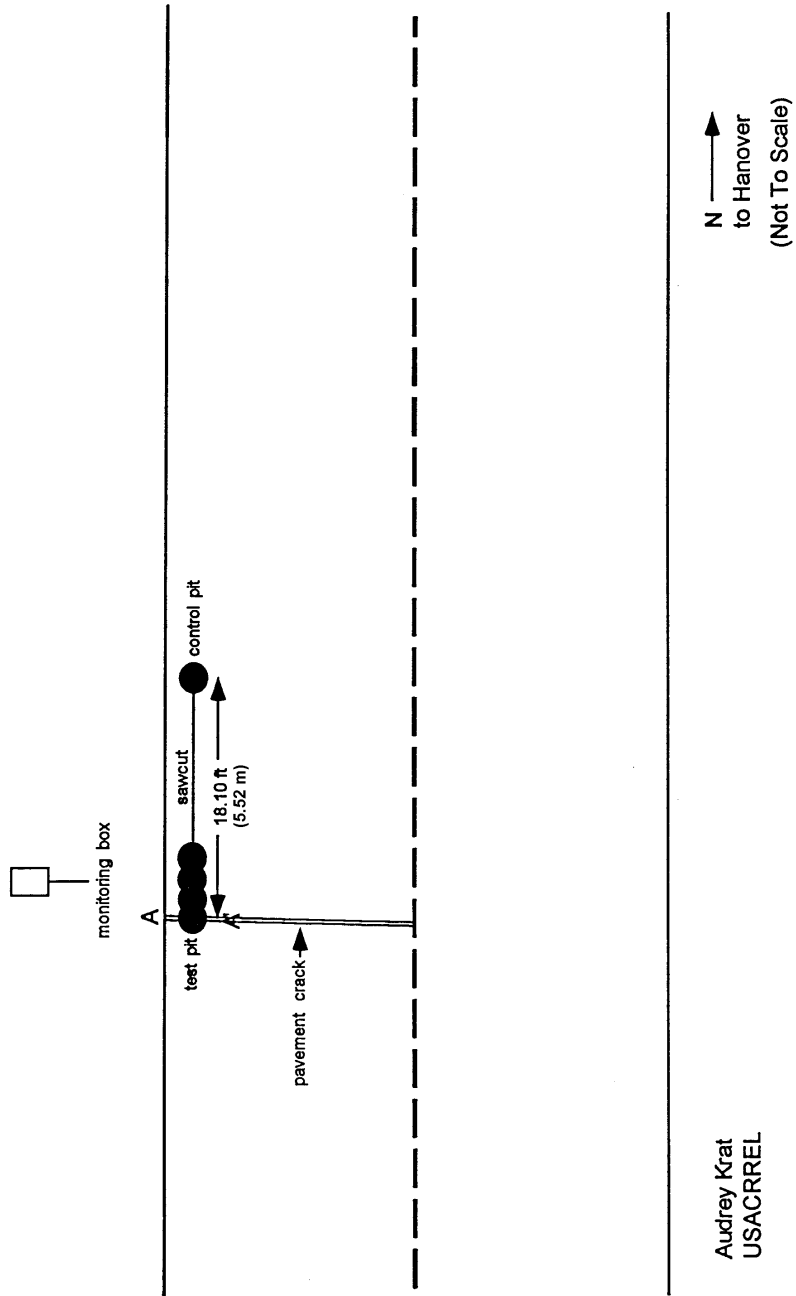

Audrey Krat  
 USACRREL

Figure A-2.

Longitudinal Cross Section of Radio Frequency Probe Locations in Test Pit - I89N

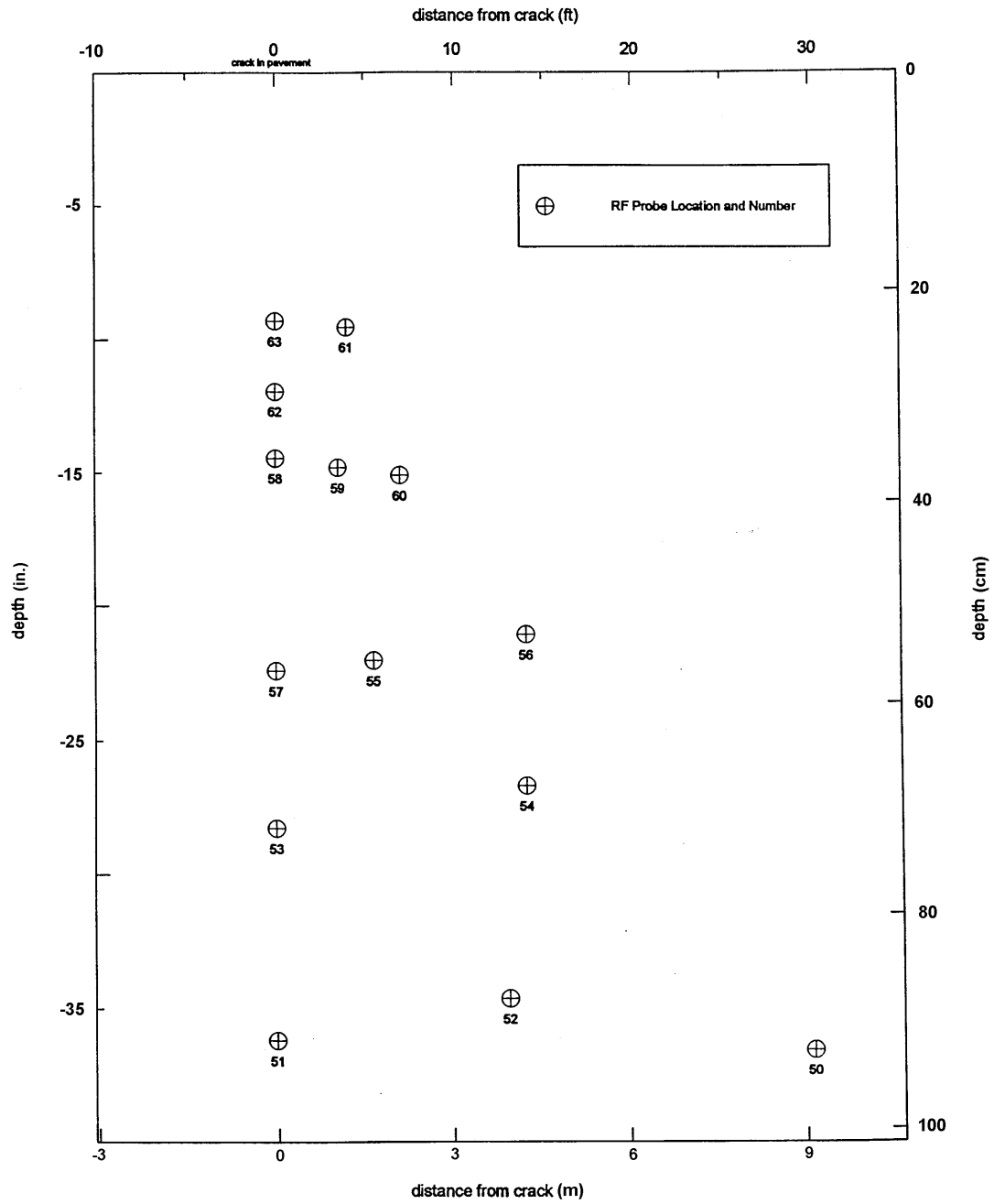

## **Appendix B**

### **Vitel Hydra Soil Moisture Sensors (Radio Frequency Probes)**



## **THEORY**

The Vitel probe measures the dielectric constant of a soil which has been shown by a long line of researchers to be related to the soil's volumetric water content (Roth et al. 1990, Schofield, et al. 1994, Kaya et al. 1994, Topp et al. 1994). Because the dielectric constant of water (80) is so much greater than that of soil particles (4) or air (1), the contribution of water dominates the overall dielectric constant of the soil-water-air mixture. Because the soil's contribution to the overall dielectric constant does not change (only the amount due to water changes as the moisture changes), soil moisture content can be readily determined. A thorough discussion of dielectric properties of moist soils is provided in Campbell (1988).

## **EQUIPMENT**

### **Probe**

Shown in Figure A-1, the moisture sensor / probe was originally developed by Dartmouth College and the US Army Cold Regions Research and Engineering Laboratory (CRREL), both located in Hanover, NH, in the 1980's. It was then further modified by, and is now commercially available from, Vitel, Inc. (Vitel, 1994) (Figure A-2). In the ensuing discussion, the original probe is referred to as the CRREL-Dartmouth probe, and the commercially available probe as the Vitel probe or sensor.

The original CRREL-Dartmouth probe and the Vitel probe function essentially identically. The major difference is that the electronics required to make the measurements were located in a "black" box for the CRREL-Dartmouth probe and have been miniaturized and placed in the probe head for the Vitel probe. High frequency (50 MHz) complex dielectric constant measurements enable determination of both soil moisture and salinity. Soil moisture is determined from the capacitive part of the soil's electrical response and salinity from the conductive part. The manufacturer's literature indicates volumetric water content is accurate within +/- 2% (Vitel, 1994).

As shown in Figure A-3, the probe consists of a multi-conductor cable, a probe head and probe sensing tines. The effective volume of soil sensed is cylindrical, bound by the outer three tines, probe head, and open end of tines (approximately 3.2 cm [1.25 in.] diameter x 5.8 cm [2.25 in.] length). A thermistor is located in the probe head to measure temperature. The probe and cable should be protected from solvents, oils/grease and strong oxidizing or reducing agents. The probe will operate from -10°C (14 °F) to +65°C (149 °F). Below -10°C, the probe will provide unreliable values but will not be damaged until -40°C (-40°F). Using the probe above +65°C (149 °F) can result in permanent damage.

...

The probe requires a 7 to 30 volt DC supply voltage with a preferred range of 7-12 VDC. The probe draws 35 to 40 mA which is a fairly high current demand. The probe outputs four voltages, V1, V2, V3, and V4 which are 0-5 VDC signals. V1 to V3 are used to determine the water content and salinity of the soil and V4 is used to determine temperature.

The cost of an individual Vitel probe with 10 ft of cable and a connector to mate with the Vitel Hydra logger is \$295 (1997 price).

# Coaxial Probe Configuration

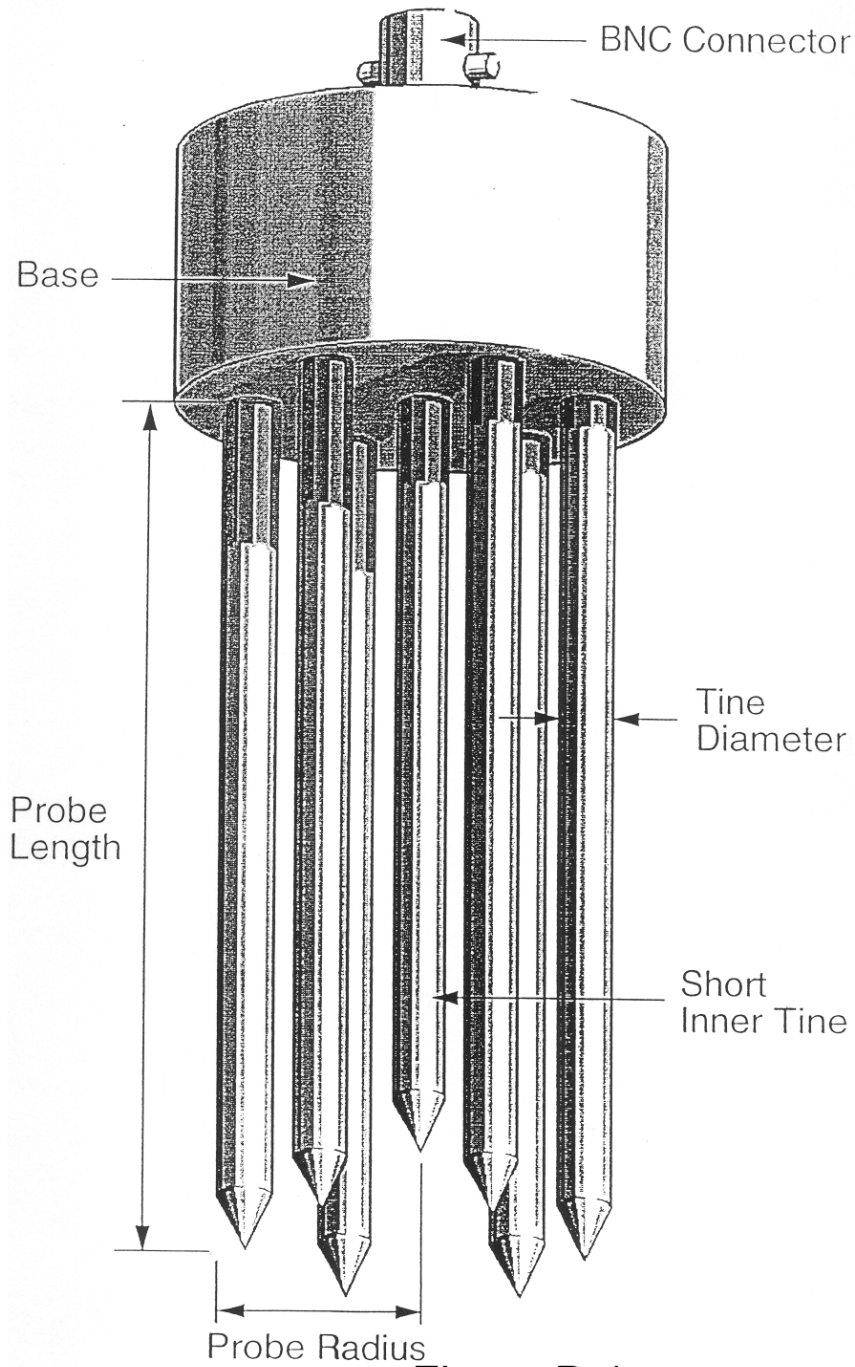

Figure B-1.



Figure B-2. Radio frequency (RF) probe.

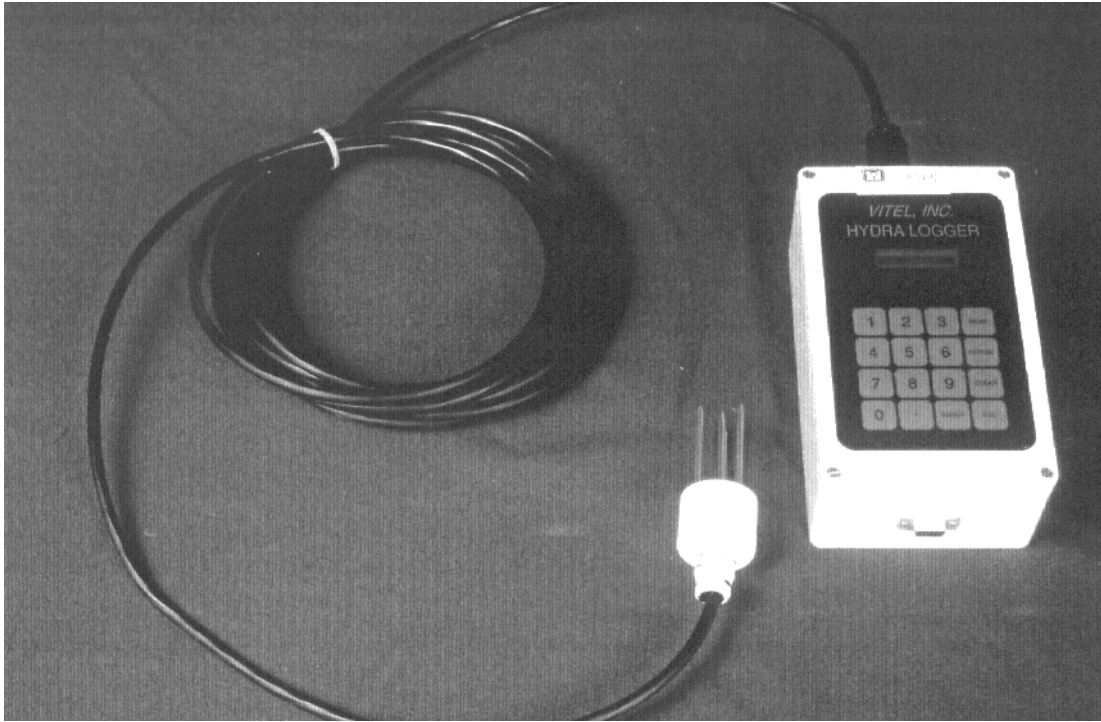
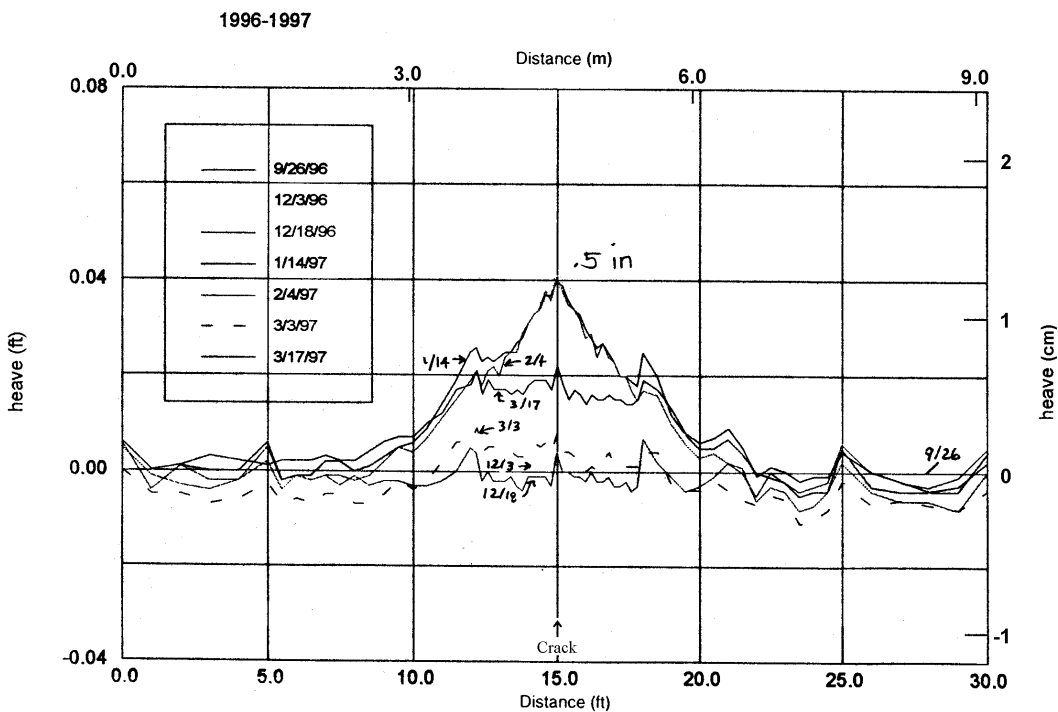
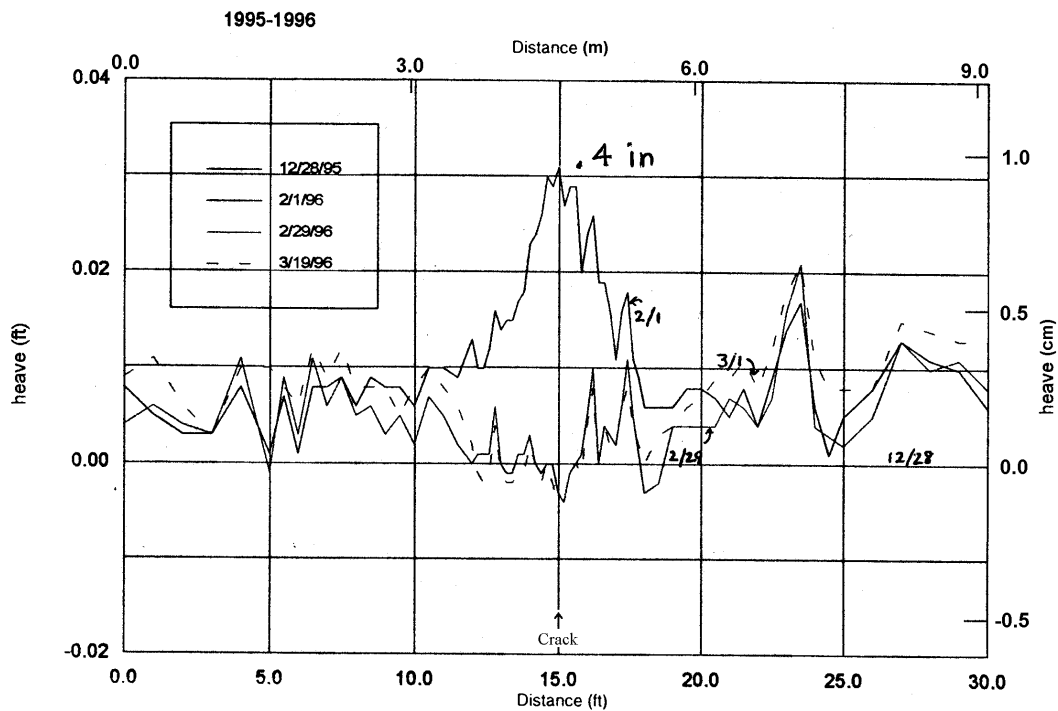

Figure B-3. Radio frequency (RF) probe with hydra logger.

## **Appendix C**

**Progression of Tenting on I-89,  
1995-1996 and 1996-1997 Winters**

SITE 4C NORTHBOUND I-89, 0.15 MI SOUTH FROM THE SUTTON/WARNER TOWN LINE



SITE A-C(2) NORTHBOUND | 89, 0.15 MI SOUTH FROM THE SUTTON/WARNER TOWN LINE

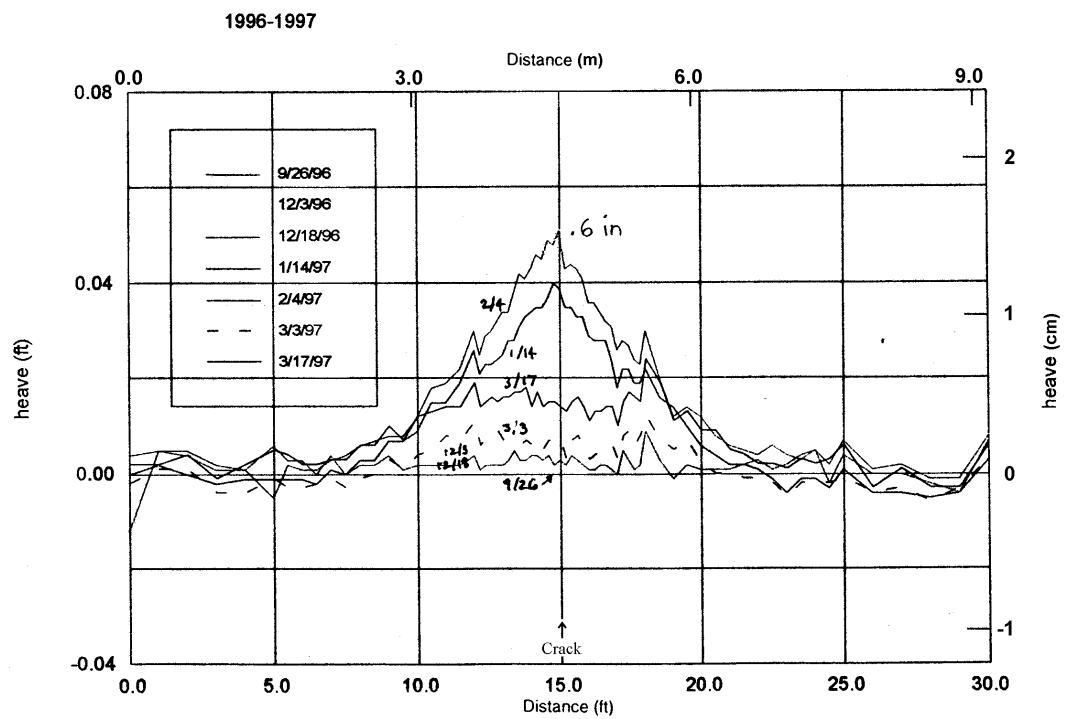
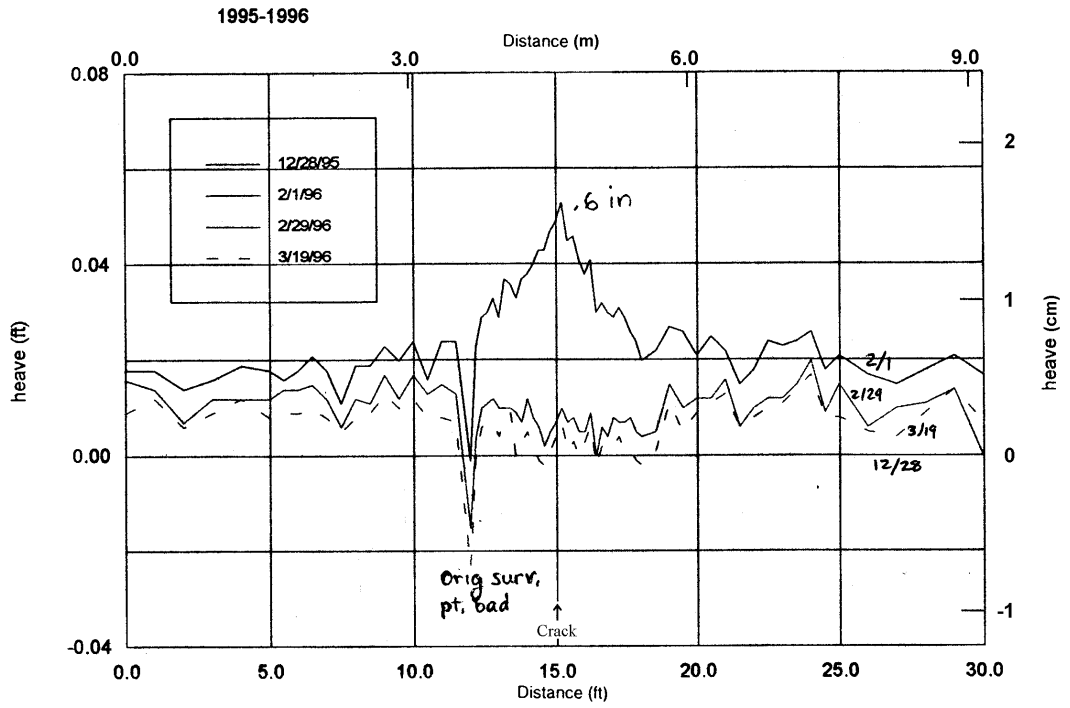



**SITE 4.b**

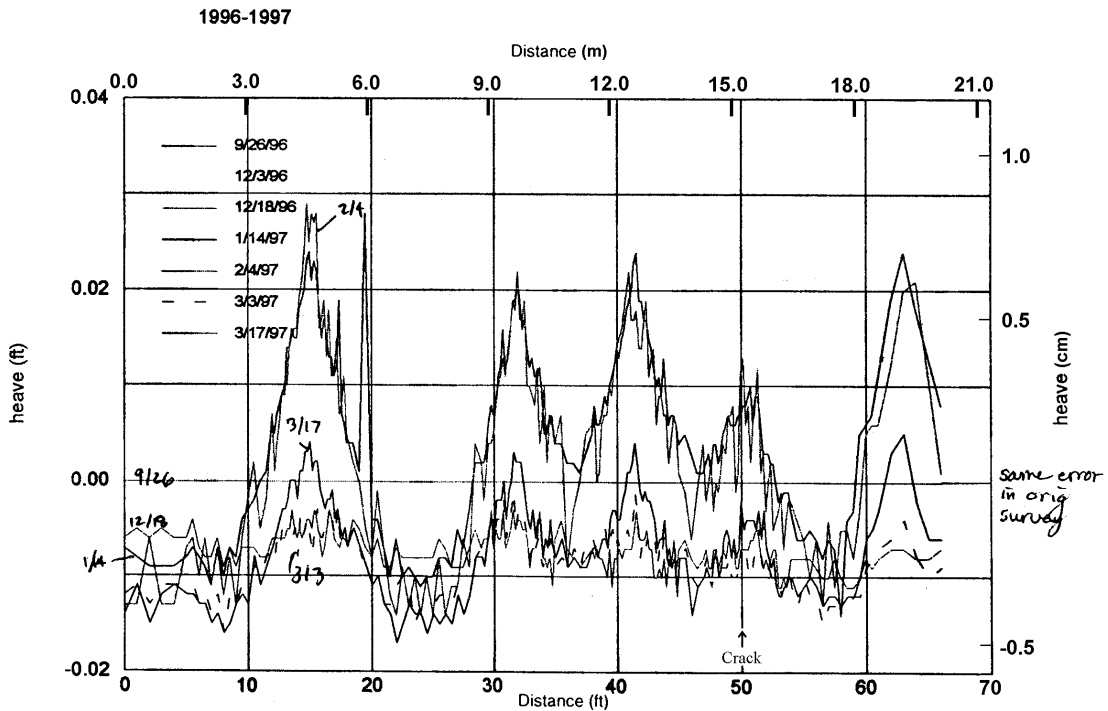
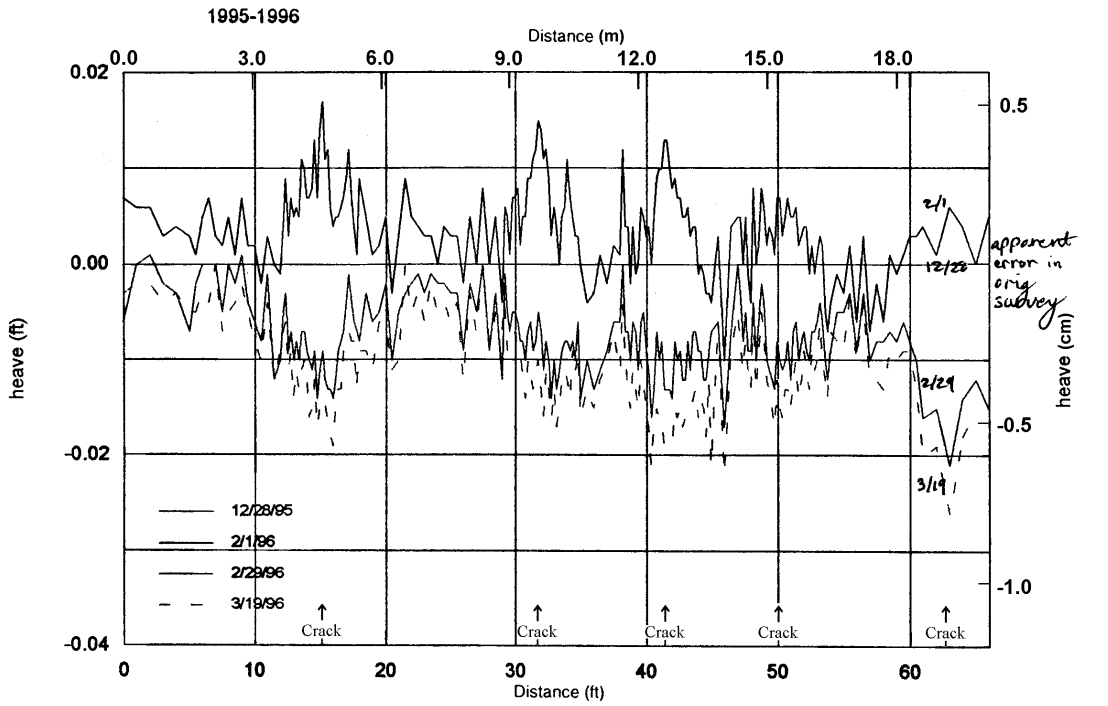

0

**SITE 4-A<sup>(1)</sup> SOUTHBOUND I-89, 0.6 MI SOUTH FROM MILE MARKER 26**  
 1995-1996

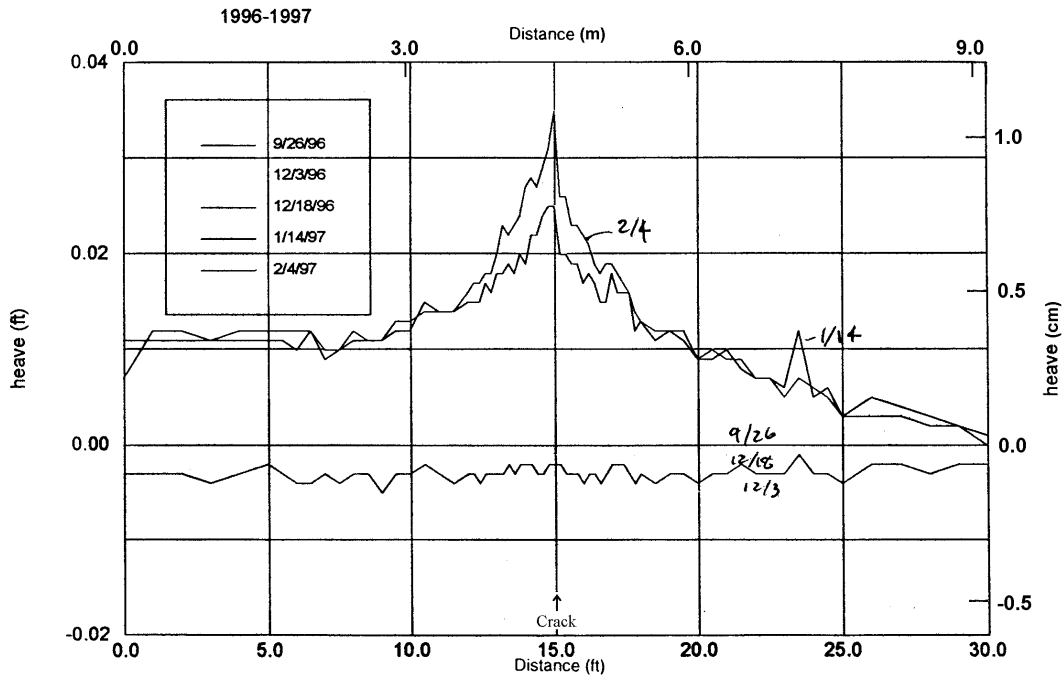
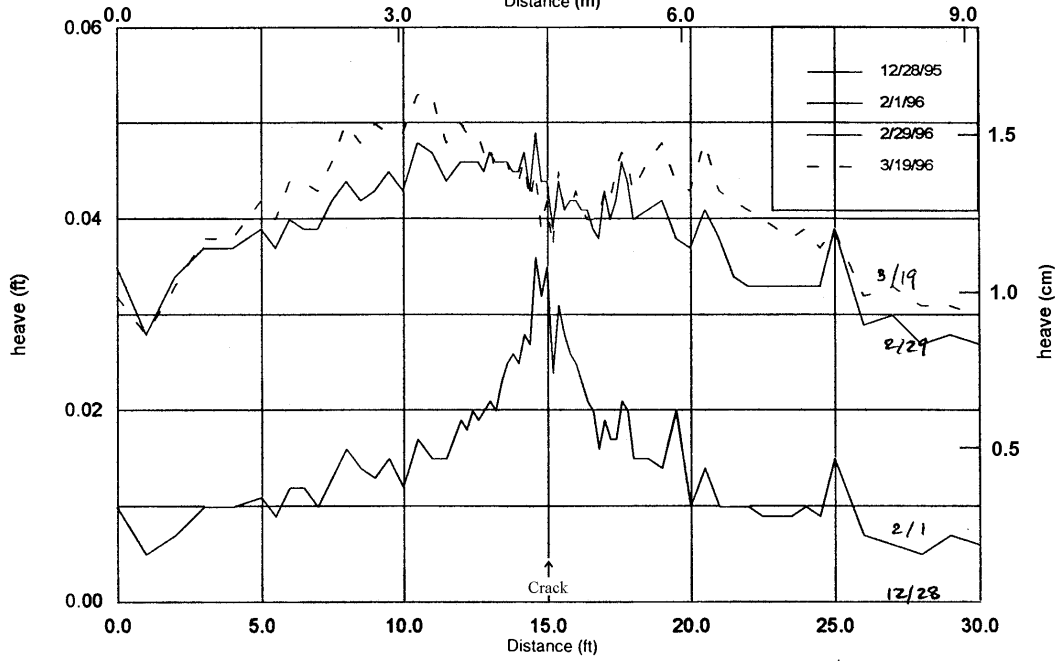

**SITE 4A<sup>(2)</sup> SOUTHBOUND I-89, 0.6 MI SOUTH FROM MILE MARKER 26**

1995-1996

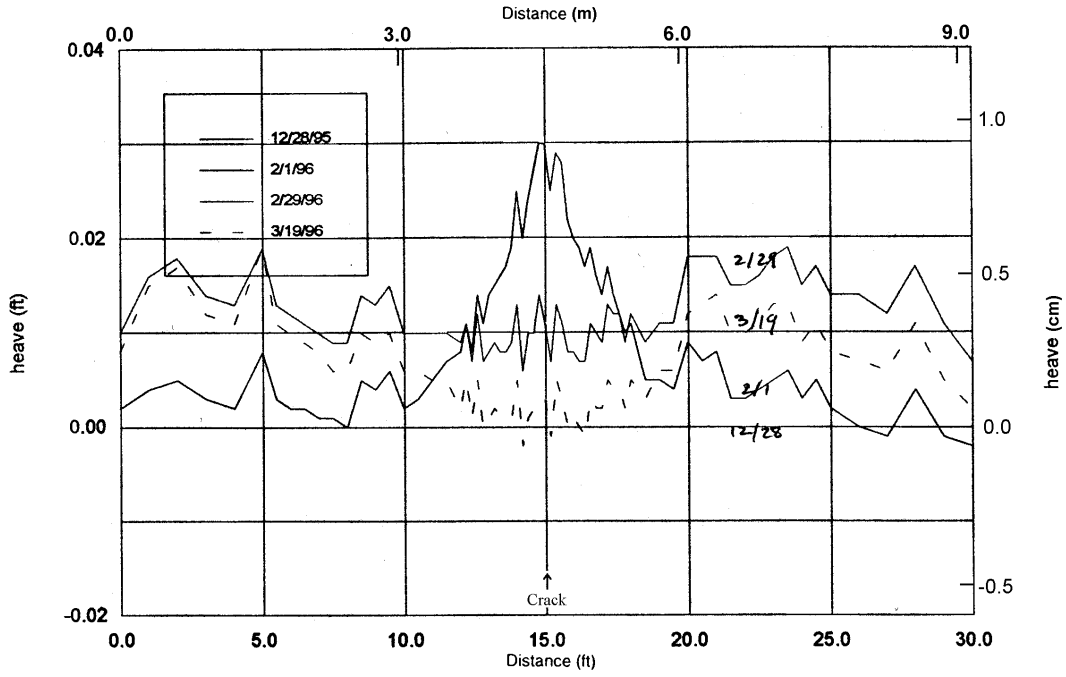

1996-1997

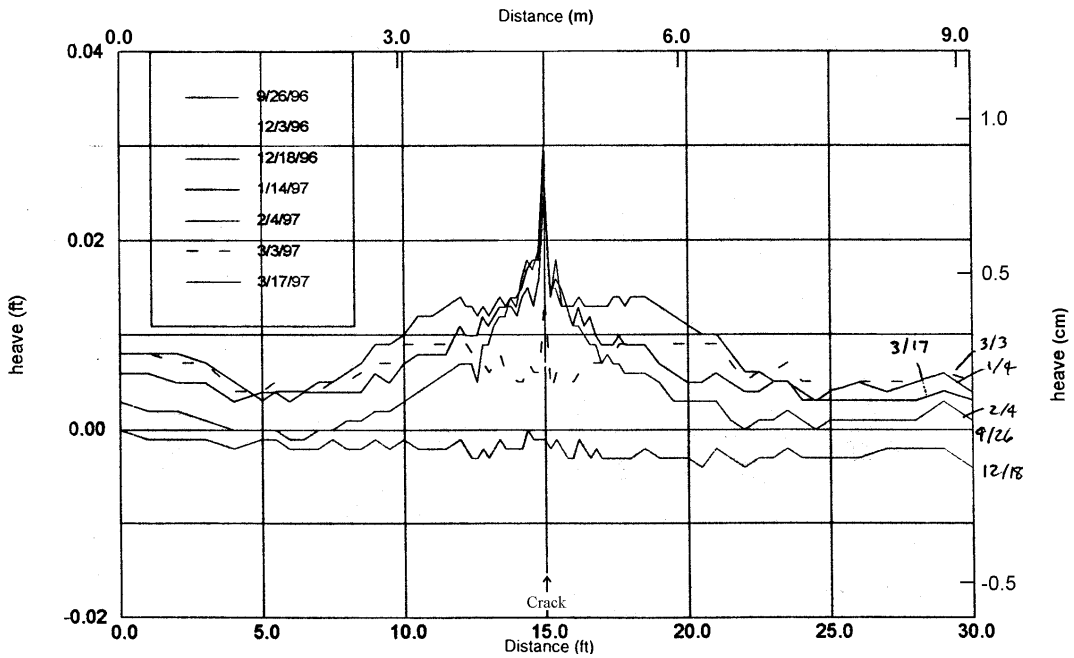

## **Appendix D**

Salinity as a (Seemingly Random) Function of Distance from Crack

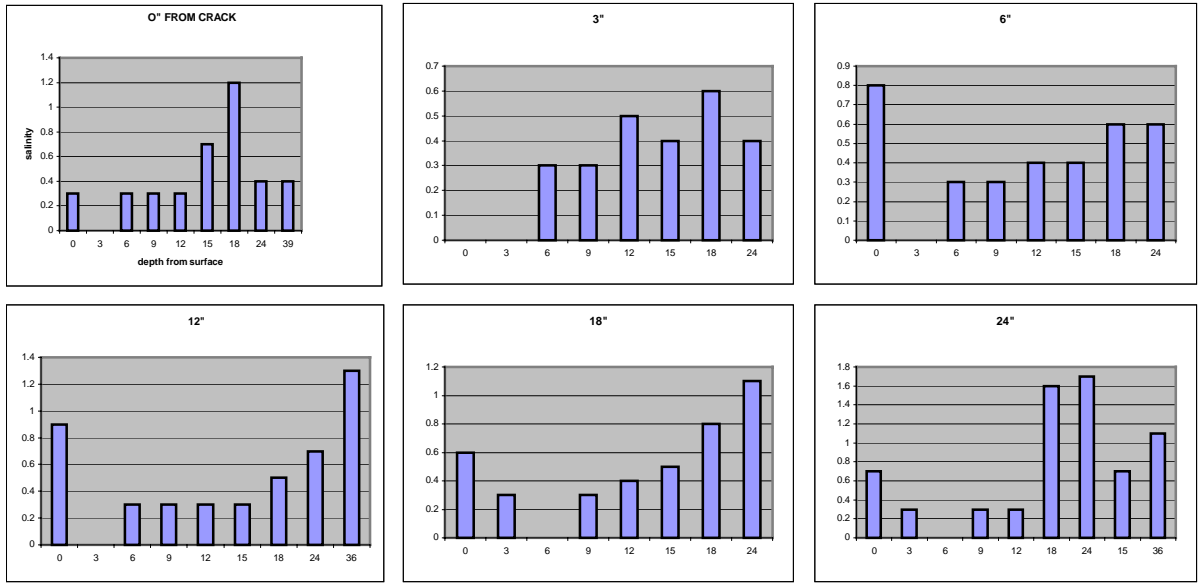

Figure D-1. Salinity – Route 112, x axis = depth from surface, y axis = salinity.

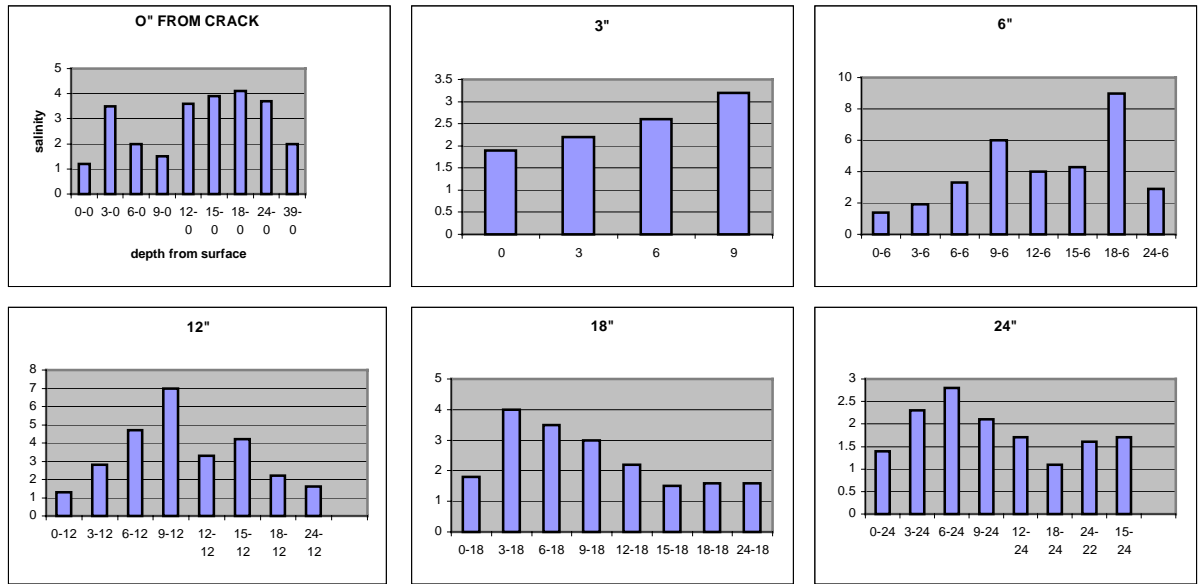

Figure D-2. Salinity – I-89 Salinity, x axis = depth from surface, y axis = salinity.

## **Appendix E**

### **Results from Informal Survey of (Northern) State Departments of Transportation**

## Informal Telephone Survey Conducted of Northern State DOTs

1. Any occurrence of winter tenting?
2. Incidence of occurrence? (i.e., observed during winter with many freeze-thaw cycles, on roads on which salt is more heavily used, only in the northern part of the state, during winters with a lot of snow, or on sloped sections of road more often than along flat sections, etc.)?
3. Theories on causes? (skipped if inferred as part of response to last question).
4. Salt use? (Approximate application rate – i.e., lbs. per mile, or truckloads per mile). Or is another de-icing agent used instead of sodium chloride?
5. Sand-salt mix -- proportions of each.
6. Sand gradation for road sand-salt mix: What % is finer than .02 mm?
7. Base course specifications: What % is finer than .02mm?
8. Other comments.

## Winter Tenting Survey

22 Sept 98

01-Keith Lane CT Dept of Trans Office of Research & Mat 280 W Street Rocky Hill, CT 06067	Ph: 860-258-0371 Fx: 860-258-0399	No, 0-5% (-200)
02-Charles Briggs KY Dept Highways Div of Operations Frankfort, KY 40622	Ph: 502-564-4556 Fx: 502-564-6640	No, Did not get information on %(-200).
03-GR Wertz Director of Maintenance PO Box 191 Columbia, SC 29202	Ph: 803-734-1290	No, Did not get information on %(-200).
04-Pete Byers Assistant Dir of Ops Oklahoma DOT 200 N.E. 21 <sup>st</sup> Street Oklahoma City, OK 73105	405-521-4675	
05-Edward Cox Indiana DOT Hwy Support Manager 100 N Senate Ave. N 925 Indianapolis, IN 46204	Ph: 317-232-5507 Fx: 317-232-5551	No, Did not get information on %(-200).
06-Joe Doherty Trans Operation Div Bldg 5 Rm 312 5 Harriman State Campus Albany, NY 12232	Ph: 518-485-7271	No, will fax sand specs
07-Eric Johnson 5800 E. Tudor Rd. Anchorage, AK 99507	Ph: 907-269-6242 Fx: 907-269-6231	No, 2% (-200) Of the 2%(-200) 50% finer than 0.02mm
08-Ed Fink State Maintenance Office 1325 S. Colorado Blvd Suite 770B Denver, Co 80222	Ph: 303-757-9536 Fx: 303-757-9719	
09-Lynn Millard/D. Anderson 4501 S. 2700 Way SLC, UT 84114	Ph: 801-965-4377 Fx: 801-965-4796	
10-Michael J. Young 700 E Broadway Pierre, SD 57501	Ph: 605-773-3704 Fx: 605-773-3421	No, 0-10% (-200) is acceptable
11-Brian Picard M & O 16 State House Station Augusta, Me 04333-0016	Ph: 207-287-2661 Fx: 207623-2526	Yes, 20 miles north of Augusta Rt 11 and North of Bangor. Not a problem. Very little maintenance. 3-12% (-200)
12-Mike Hedges Vermont Agency of Trans 133 State Street Montpelier, VT 05633	Ph: 802-828-2793 Fx: 802-828-2848	Testing-Allan Schneck(828-2561)



13-Al Hammonds WV Highway Operations Div Rm 350A 1900 Kanawha Blvd East Charleston, WV 25305	Ph: 304-558-2901 Fx: 304-558-2912	Yes, but with 7-10" concrete base course, all interstate system- approx 2,000 miles, up to 1/4" crack
14-Greg Buterbaugh, RPS 55 Walnut Street 7 <sup>th</sup> Floor Forum Place, BOMO Harrisburg, PA 17101-1900	Ph: 717-787-6522 Fx: 717-787-7839	No, 4-5% (-200)
15-Ed Ryen NDDOT-Maint Div 608 E. Boulevard Ave Bismark, ND 58505-0700	Ph: 701-328-4274 Fx: 701-328-4623	
16-David Spangenberg Mich DOT PO Box Lansing, MI 48917	Ph: 517-373-7682	
17-Thomas Martinelli WI DOT Bureau of Hwy Ops PO Box 7986, Rm 951 Madison WI, 53707-7986	Ph: 608-266-3745 Fx: 608-267-7856 Ph: 715-365-5733	Yes, Jim Voborski
18-John Selmer IA DOT 800 Lincoln Way Ames IA, 50010	Ph: 515-239-1589 Fx: 515-239-1005	
19-Thor Dyson 1263 S Stewert St Carson City NV, 89712???	Ph: 702-834-8300	
20-Paul M. Cammack PO Box 94759 Lincoln, NE 60509-4759	Ph: 402-479-4542 Fx: 402-479-3918	
21-Richard R. Stapp, P.E. P.O. Box 1708 Cheyenne, Wy 82003-1708	Ph: 307-777-4456 Fx: 307-777-4765	No, 0-10% (-200)
22-Jeff Gower 800 Airport Rd. Salem, OR 97310	Ph: 503-986-3123 Fx: 503-986-3096	No, use liquid de-icer.

**Appendix E cont'd:**  
**Gradation specifications provided by several states in response to telephone survey.**

STATE OF NEW HAMPSHIRE  
DEPARTMENT OF PUBLIC WORKS AND HIGHWAYS  
MATERIALS AND RESEARCH DIVISION

GRAIN SIZE ANALYSIS  
(MECHANICAL)

PROJECT \_\_\_\_\_ PROJECT NO. \_\_\_\_\_  
 LABORATORY NO. 19 FIELD NO. \_\_\_\_\_  
 TYPE OF MATERIAL Gravel PURPOSE USED (ITEM) \_\_\_\_\_  
 SUBMITTED BY R. Perkins REPORT TO \_\_\_\_\_  
 SAMPLED 5/9/95 FROM Cook QUANTITY REPRESENTED \_\_\_\_\_  
 SOURCE OF MATERIAL Active face TOWN Norwich VT.  
 EXAMINE FOR \_\_\_\_\_ TESTED BY R. Perkins DATE 5/12/95

Sieve Size	TEST NO. <u>19</u>			In Total Percent Passing
	Accum. Weight Retained	Percent Retained	Percent Passing	
3"				
2"	1.9	6		94
1 1/2"	5.0	16		84
1"	7.4	23		77
3/4"				
1/2"	9.8	31		69
3/8"				
#4	12.1	37.8		62.2

Fractured  
Faces

Sieve Size	Minus #4 Fraction			In Total Percent Passing
	Accum. Weight Retained	Percent Retained	Percent Passing	
#10	81	14	86	
#20	232	40	60	
#40	375	65	35	
#100	516	89	11	
#200	546.3	94.3	5.7	3.5

Percent  
Moisture

Sieve Size	TEST NO. _____			In Total Percent Passing
	Accum. Weight Retained	Percent Retained	Percent Passing	
3"				
2"				
1 1/2"				
1"				
3/4"				
1/2"				
3/8"				
#4				

Fractured  
Faces

Sieve Size	Minus #4 Fraction			In Total Percent Passing
	Accum. Weight Retained	Percent Retained	Percent Passing	
#10				
#20				
#40				
#100				
#200				

Percent  
Moisture

REMARKS: \_\_\_\_\_  
 \_\_\_\_\_  
 \_\_\_\_\_  
 \_\_\_\_\_

MGR-1

NH BASES

TABLE 1  
BASE COURSE MATERIALS

SIEVE SIZE	REQUIRED GRADATION						% PASSING BY WEIGHT			
	ITEM NO.	304.1	304.2	304.3	304.33	304.4	304.5			
ITEM		SAND	GRAVEL	CR. GRAVEL	MODIFIED CR. GRAVEL	CR. AGGREGATE FOR SHOULDERS	CR. STONE (FINE)	CR. STONE (COARSE)		
6"		100	100	---	---	---	---	---	---	---
5"		---	---	---	---	---	---	---	---	---
4"		---	---	---	---	---	---	---	---	---
3-1/2"		---	---	---	---	---	---	---	---	---
3"		---	---	100	100	---	---	---	100	85-100
2"		---	---	95-100	95-100	---	100	---	---	---
1-1/2"		---	---	---	---	100	85-100	---	---	60-90
1"		---	---	55-85	---	90-100	---	---	---	---
3/4"		---	---	---	---	---	45-75	---	---	40-70
#4		70-100	25-70	27-52	27-55	30-65	20-45	---	---	15-40
#200 (In Sand Portion)*		0-12	0-12	0-12	0-12	---	---	---	---	---
#200 (In Total Sample)		---	---	---	---	0-10	0-5	---	---	0-5

\* FRACTION PASSING THE NO. 4 SIEVE

CONNECTICUT DEPARTMENT OF TRANSPORTATION  
BUREAU OF ENGINEERING AND HIGHWAY OPERATIONS

SPECIFICATION FOR  
COVER SAND FOR SNOW AND ICE CONTROL

REFERENCE FILE NUMBER 182-F

Issued March 12, 1976  
Revised June 1, 1998

SCOPE: This specification applies to cover sand for snow and ice control.

DESCRIPTION: This sand shall consist of clean, hard, durable and uncoated particles of quartz or other rock and shall be free from lumps of clay, soft or flaky material, loam or other detrimental material.

The sand shall contain not more than five percent (5%) of material finer than the 75  $\mu$ m sieve, using AASHTO Method T 11.

The sand shall conform to the following gradation requirements:

Square Mesh Sieve	% Passing By Mass
9.5 mm	100
4.75 mm	70-100
300 $\mu$ m	0-40
150 $\mu$ m	0-15
Material finer than 75 $\mu$ m	0-5

Washed Sand: If washed sand is supplied, it shall be stockpiled at least twenty-four (24) hours before use.

In no case shall sand be used that contains frozen lumps or other detrimental material.

ATTACHMENT C

UTAH DEPARTMENT OF TRANSPORTATION  
 DESLICKING GRIT TYPE II  
 SPECIFICATIONS

Deslicking grit shall consist of a natural stone or manufactured abrasive material conforming to the following requirements:

- a) The aggregate shall be either a natural or manufactured product which shall have no more than two (2%) by weight of vegetable matter or other deleterious substance.
- b) That portion of the fine aggregate passing the No. 40 sieve shall be non-plastic when tested in accordance with AASHTO Designation T-90.
- c) The portion of fine aggregate passing the No. 200 sieve shall be determined by washing with water in accordance with AASHTO Designation T-11.
- d) The dry mineral aggregate shall be of such size to meet one of the following gradation specifications.

GRADATIONS

Loose Unit Weight

40-60 lb/ft<sup>3</sup>    60-80 lb/ft<sup>3</sup>    80-100 lb/ft<sup>3</sup>    100-125 lb/ft<sup>3</sup>

Screen Passing

¾" - 100	100	---	---
3/8" - 85-100	90-100	100	100
1/4" - ---	---	80-100	95-100
#4 - 60-100	60-100	45-100	45-100
#8 - 15-75	15-75	30-80	30-80
#200 - 0-10	1-10	0-15	0-15

- e) The dry unit weight of the material shall be between 40 lb/ft<sup>3</sup> and 125 lb/ft<sup>3</sup> when measured according to the loose weight determination as described in AASHTO Designation T-19. The moisture content shall be determined according to ASTM D-2216.
- f) The material shall have a sand equivalency of 60 or greater when tested in accordance with Utah Department of Transportation's (UDOT) Materials Manual, Part 8, Sand Equivalency Test, 9-938.

## STOCKPILE METHODS

### DESLICKING GRIT

Stockpile method - The method for stockpiling will be specified in each contract for each station. The method will be one of the following:

- (1) Stockpile by butting loads - Stockpiles shall be built at designated locations. Supplier may use end dumps, end dumps and pups, or belly dumps to haul material. End dump loads shall be butted one against the other in such a manner as to occupy as small a total stockpile area as possible. If the supplier elects to use belly dumps or pups he must supply equipment to keep the stockpile pushed up to cover an area no larger than as if he had used end dumps. If, for any reason, the Engineer is not satisfied with the stockpiling, the supplier will be responsible to reshape the stockpile to an acceptable configuration. If UDOT personnel are forced to reshape the stockpile, the cost of reshaping will be deducted from the contract.
- (2) Stockpile by supplier furnished loader - Stockpiles shall be built at designated locations. Supplier may use end dumps, end dumps and pups or belly dumps. Each load will be placed and "bucked up" by a supplier furnished loader and operator. Stockpiles will be built to occupy as little space as possible and "bucked up" to a uniform 10 foot height. If, for any reason, the Engineer is not satisfied with the stockpiling, the supplier will be responsible to reshape the stockpile to an acceptable configuration. If UDOT personnel are forced to reshape the stockpile, the cost of reshaping will be deducted from the contract.
- (3) Stockpile by state forces shaping pile - Stockpiles shall be built at designated locations. Supplier may use end dumps, end dumps and pups or belly dumps. The stockpiles will be shaped by state forces.

- g) The deslicking grit shall be sampled and tested in stockpiles at maintenance stations to determine compliance with gradation specifications. Out of specification material will be rejected and ordered to be removed. The supplier shall not be paid for any such material or its removal costs.

Method of Measurement - The material will be paid for by the cubic yard with the quantities to be determined using one of the following methods:

- 1) The following formula is to be used to convert pounds of material to cubic yards of material.

$$\text{Cubic Yards} = \frac{W - (WM)}{(U)27}$$

W= Weight of material delivered determined from weight tickets.

M= Percent moisture determined from samples taken when delivered.

U= Unit weight of material as determined in part (e) above. This factor shall be determined from samples obtained by the UDOT Region Materials Lab closest to the source. The determination for the value of this factor shall be made and agreed upon prior to commencement of hauling operations. Once determined and agreed upon this factor shall be used for the entire contract.

- 2) The Contractor will place the material in a uniform stockpiled of such configuration to allow for accurate field measurement. The computation of quantities will be the sole responsibility of the UDOT Engineer.





Fax to:  
~~603~~ 603  
~~603~~ 646-4640  
*[Signature]*

TO Charlie Smith, Corps of Engineers PHONE \_\_\_\_\_

FROM Joe Doherty, NYS DOT PHONE 485-7271  
(518)

PAGES 3 (including cover sheet) DATE 9/21/98  
9/22/98

COMMENTS The attached 2 sheets are our bid  
specs for road sand gradations. Most of  
the state uses "A" gradation, however the  
northernmost areas (Our Regions 7, 2 and upper  
Region 1) use a good deal of "B" and very  
rarely "C".

- DO NOT USE FOR BID ELIGIBILITY -

REJECTION GRADATION SHEET \*\*

GRADATION	SIEVE SIZE	PERCENT PASSING REJECTION GRADATION	PENALTY FACTOR
A	1/2"	100	-
	3/8"	95-100	1
	#4	70-100	1
	#50	0-22	2
	#200	0-5	5
B	1/2"	100	-
	3/8"	95-100	1
	#4	70-100	1
	#50	0-30	2
	#200	0-8	5
C	1/2"	100	-
	3/8"	95-100	1
	#4	70-100	1
	#50	0-40	2
	#200	0-8	5

\*\*NOTE: THE ABOVE TABLE IS NOT TO BE USED TO DETERMINE BID ELIGIBILITY (SEE SPECIFICATION GRADATION SHEET FOR THAT USE). REJECTION GRADATION IS USED TO DETERMINE THE ACCEPTABILITY OF DELIVERED MATERIAL AND CALCULATE APPLICABLE REDUCED PAYMENT.

-USE FOR BID ELIGIBILITY -  
 SPECIFICATION GRADATION SHEET\*

	PERCENT PASSING	
GRADATION	SIEVE SIZE	SPECIFICATION GRADATION
A	1/2"	100
	3/8"	100
	#4	80-100
	#50	0-18
	#200	0-3
<hr/>		
B	1/2"	100
	3/8"	100
	#4	80-100
	#50	0-25
	#200	0-5
<hr/>		
C	1/2"	100
	3/8"	100
	#4	80-100
	#50	0-35
	#200	0-5

\*NOTE: THE ABOVE TABLE IS TO BE USED FOR DETERMINING BID ELIGIBILITY. TO BE ACCEPTABLE, THE GRADATION ANALYSIS SUBMITTED WITH THE BID MUST SHOW THAT THE PROPOSED SOURCE MEETS THE ABOVE SPECIFICATIONS.



Commonwealth  
of Pennsylvania

Department  
of Transportation



From the Desk of  
Greg Buterbaugh, Roadway Programs Specialist  
Bureau of Maintenance & Operations  
555 Walnut Street - 7th Floor Forum Place  
Harrisburg, PA 17101-1900  
Phone: 717-787-6522 -- FAX 717-787-7839

To: Charlie Smith

Number of pages including cover : 3

**703.4 ANTI-SKID MATERIAL —**

(a) **General.** Furnish material, from a supplier listed in Bulletin 14, meeting the gradation of Table E for use on ice or snow-covered pavement surfaces. Only material not containing substances such as metal or glass, substances which may be harmful to automotive equipment and vehicles, and material reasonably free of deleterious substances or foreign materials, will be acceptable. Deleterious substances or foreign materials include, but are not limited to, dirt, shale, slate, incinerated bituminous coal mine waste, and as listed in Section 703.2(a), Table B, Type C.

(b) **Description.**

1. **Types 1 and 1A.** Cinders (dry bottom ash), coke, boiler slag (wet bottom ash), or a combination of these. Boiler slag is the glass residue of water-quenched molten ash, obtained from coal-burning boilers.

Meet the following requirements:

- an air-dry loose weight of not less than 35 pounds per cubic foot, as determined in accordance with PTM No. 609;

703.4(b)

*Aggregate*

703.4(c)

- Type 1, having a unit weight of 76 pounds per cubic foot or less, or Type 1A, having a unit weight of more than 76 pounds per cubic foot;
  - crushed brick, crushed stone, slag, or gravel may be present in amounts not exceeding a total of 3% by weight, as determined by the weight of this material retained on the 1/2-inch sieve and by the total dry weight of the sample; and
  - unburned or partially burned coal may be present in amounts not exceeding 7% by weight, as determined by the weight of this material retained on the 3/8-inch sieve and by the total dry weight of the sample.
2. **Type 2.** Crushed stone, crushed gravel, or crushed slag, meeting the following requirements:
- Not exceeding 105 lbs. per cubic foot;
  - Los Angeles Abrasion loss, not exceeding 55% by weight, as determined in accordance with AASHTO-T96, Gradation D; and
  - When crushed gravel is furnished, not less than 85% of the fragments retained on the #8 sieve are required to be crushed, one face, as determined in accordance with PTM No. 621.
3. **Types 3, 3A, and 3B.** Either natural sand, with not less than 35% of the material retained on the #8 sieve being crushed fragments, as determined in accordance with PTM No. 621; or manufactured sand, except limestone sand; or a combination of these.
4. **Type 6S.** Crushed stone, crushed gravel, or crushed slag meeting the following requirements:
- Not exceeding 105 lbs. per cubic foot;
  - Los Angeles Abrasion loss not exceeding 55% by weight as determined in accordance with AASHTO-T96, Gradation D; and
  - When crushed gravel is furnished, not less than 60% of the fragments retained on the #4 sieve are required to be crushed, one face, as determined in accordance with PTM No. 621.
- (c) **Gradations.** Conforming to the gradation of Table E, as determined in accordance with PTM No. 624.

TABLE E — ANTI-SKID GRADATION									
Anti-Skid Type	Maximum Percent Passing								
	1/4"	3/4"	1/2"	3/8"	#4	#8	#50	#100	#200
Type 1	100					70	18		
Type 1A		100	90-100			55	18		
Type 2			100	95-100		30		8	
Type 3				100		85		8	
Type 3A				100		55		8	
Type 3B				100	85-100	55		5	4*
Type 6S				100	35-85	55		8	5*

\*As determined by PTM No. 100

(d) **Testing.** Test material for moisture content when shipping to Department stockpiles. Conduct tests, in accordance with PTM No. 513. Have the results verified by a Department representative. A minimum of two tests per day is required. When conditions exist which would cause a change in moisture content, additional tests are required. Document tests at the end of delivery tonnage at the end of the day and determine the average moisture content. An adjustment of the delivery tonnage will be required, based on the average moisture content. The percent of moisture will be deducted from the aggregate tonnage shipped, and payment will be based on the calculated oven dry weight.