

GENERAL NOTES

- ITEM 529.6, PRECAST CONCRETE SOUND ABATEMENT WALL (F) SHALL INCLUDE, ALL PRECAST CONCRETE SOUNDWALL PANELS, POSTS, LEVELING PANELS, STEEL BASE PLATES, CLOSED CELL EXPANSION MATERIAL, AND ALL HARDWARE AND INCIDENTAL MATERIALS NECESSARY FOR CONSTRUCTION OF THE SOUNDWALL AS DETAILED ON THE PLANS.
- SEE SECTION 529 SPECIAL PROVISION FOR ADDITIONAL INFORMATION AND REQUIREMENTS.
- THE ANGLE BETWEEN THE PRECAST CONCRETE POST AND WALL PANEL SHALL NOT EXCEED 10 DEGREES. POSTS SHALL BE HORIZONTALLY ALIGNED TO ACHIEVE THE PROPOSED WALL ALIGNMENT WITH ANGLE POINTS NOT TO EXCEED 20 DEGREES.
- TRANSITIONS IN TOP OF WALL ELEVATION SHALL BE AS DETAILED ON THE PLANS.
 - WHERE THE TOP OF WALL ELEVATION IS THE SAME ON BOTH SIDES OF A POST, THE MAXIMUM ALLOWABLE DISTANCE FROM THE TOP OF WALL TO TOP OF POST SHALL BE 6".
 - WHERE THE TOP OF WALL ELEVATION VARIES ON BOTH SIDES OF A POST THE MAXIMUM ALLOWABLE DISTANCE FROM THE TOP OF WALL TO TOP OF POST SHALL BE 12".
- ALL PANELS SHALL BE 4'-0" TALL, EXCEPT FOR THE UPPER TWO PANELS BETWEEN EACH POST, WHICH SHALL VARY IN HEIGHT TO ACHIEVE THE DESIRED TOP OF WALL ELEVATION.
- THE MAXIMUM POST SPACING SHALL BE 18'-0" OR 20'-0" BASED ON EXPOSURE HEIGHT OF WALL (SEE DETAIL AND TABLE THIS SHEET). ALL POSTS SHALL BE SPACED AT THE MAXIMUM POST SPACING UNLESS A REDUCED POST SPACING IS REQUIRED TO AVOID UNDERGROUND OR OTHER CONFLICTS.
- FOR LAYOUT OF SOUNDWALL (INCLUDING POST/SHAFT NUMBERS, WORKING POINT COORDINATES, AND WALL ELEVATIONS), SEE PLAN SHEETS INCLUDED ELSEWHERE IN THIS CONTRACT.
- VERTICAL REINFORCING STEEL FOR THE POSTS SHALL HAVE THE LAST 5" THREADED. ANCHOR RODS SHALL HAVE THE FIRST 8" THREADED. THREADING SHALL BE TO THE SIZE SPECIFIED ON THE PLANS AND IN ACCORDANCE WITH SECTION 550.
- COAT ALL PRECAST SURFACES (SOUNDWALL PANELS, POSTS, AND LEVELING PANELS) WITH WATER REPELLENT (SILANE-SILOXANE) IN ACCORDANCE WITH SECTION 534. ALL COSTS SUBSIDIARY TO ITEM 529.6.
- CLEAR COVER FOR REINFORCEMENT SHALL BE AS SHOWN ON THE PLANS.
- ALL EXPOSED CONCRETE EDGES SHALL BE CHAMFERED 3/4" UNLESS OTHERWISE NOTED.
- PRECAST CONCRETE SOUNDWALL PANELS SHALL HAVE A SC - ASHLAR ARCHITECTURAL FINISH ON BOTH FACES, CAST USING PATTERN NO. 1515 FORM LINERS BY SPEC FORMLINERS, INC. PRECAST CONCRETE LEVELING PANELS SHALL BE CAST SMOOTH. SEE SECTION 529 SPECIAL PROVISION FOR MORE INFORMATION.
- LIFTING POINTS AND DEVICES SHALL BE DESIGNED BY THE CONTRACTOR AND SUBMITTED FOR APPROVAL. ALL UPWARD FACING RECESSES FOR LIFTING DEVICES SHALL BE FILLED WITH AN APPROVED NON-SHRINK GROUT AFTER OR DURING ERECTION.

DESIGN CRITERIA

- SPECIFICATIONS: AASHTO LRFD BRIDGE DESIGN SPECIFICATIONS, 9TH ED., 2020, SECTION 15 NHDOT 2016 STANDARD SPECIFICATIONS AS AMENDED, SPECIAL PROVISION SECTION 529 - PRECAST CONCRETE SOUND ABATEMENT WALL
- DESIGN LOADING: WIND PRESSURE (STRENGTH III):
 - 42 PSF (EXPOSURE HEIGHT = 40')
 - 46 PSF (EXPOSURE HEIGHT = 60')
 WHERE:
 - $V = 123$ MPH (AASHTO FIG. 3.8.1.1.2-1)
 - $Kz(c)$ GROUND SURFACE ROUGHNESS CATEGORY C, OPEN TERRAIN
 - $G = 0.85$
 - $C_D = 1.2$
 - $= 1.05$ (EXPOSURE HEIGHT = 40')
 - $= 1.14$ (EXPOSURE HEIGHT = 60')
- DESIGN DIMENSIONS: MAXIMUM WALL HEIGHT = 25'-0"
MAXIMUM POST SPACING = 18'-0" OR 20'-0" (SEE GENERAL NOTE 6)
- MATERIALS:
 - CONCRETE FOR THE SOUNDWALL PANELS, POSTS, AND LEVELING PANELS SHALL HAVE A MINIMUM 28 DAY COMPRESSIVE STRENGTH OF 4,000 PSI AND SHALL CONFORM TO SECTION 520 FOR CLASS AA CONCRETE UNLESS NOTED OTHERWISE. ALL PRECAST CONCRETE SHALL HAVE CORROSION INHIBITOR (CALCIUM NITRATE) ADMIXTURE ADDED AT A RATE OF 3 GALLONS PER CUBIC YARD.
 - ALL REINFORCING STEEL SHALL CONFORM TO AASHTO M 31, (ASTM A615) GRADE 60. ALL WELDED WIRE FABRIC SHALL CONFORM TO AASHTO M55.
 - VERTICAL REINFORCING STEEL FOR THE POSTS SHALL BE GALVANIZED AFTER FABRICATION IN ACCORDANCE WITH SECTION 529 SPECIAL PROVISION. TIE BARS IN POSTS SHALL BE GALVANIZED OR EPOXY COATED IN ACCORDANCE WITH SECTION 544. REINFORCING BARS AND WELDED WIRE FABRIC IN THE SOUNDWALL PANELS AND LEVELING PANELS SHALL BE BLACK (UNCOATED) STEEL.
 - STRUCTURAL STEEL FOR BASE PLATES SHALL CONFORM TO ASTM A572, GRADE 50 AND BE GALVANIZED AFTER FABRICATION IN ACCORDANCE WITH SPECIAL PROVISION SECTION 529.
 - ANCHOR RODS SHALL CONFORM TO AASHTO M 31 (ASTM A615), GRADE 60 AND SHALL BE FABRICATED IN ACCORDANCE WITH SECTION 550. ANCHOR RODS SHALL BE GALVANIZED IN ACCORDANCE WITH SPECIAL PROVISION SECTION 529.
 - NUTS SHALL CONFORM TO ASTM A563, GRADE DH AND WASHERS SHALL BE HARDENED AND CONFORM TO ASTM F436, TYPE 1. ALL HARDWARE SHALL BE GALVANIZED IN ACCORDANCE WITH SPECIAL PROVISION SECTION 529.

PRECAST CONCRETE TOLERANCES

- POST DIMENSIONAL TOLERANCES:
 - TOTAL HEIGHT = $\pm 1/2"$
 - FLANGE WIDTH = $\pm 1/4"$
 - WEB THICKNESS = $\pm 1/4"$
 - SLOT DEPTH AND LOCATION = $\pm 1/8"$
 - VERTICAL SWEEP POSTS $\leq 15.0'$ = $\pm 1/8"$
 - VERTICAL SWEEP POSTS 15.1' TO 25.0' = $\pm 1/4"$
- PANEL DIMENSIONAL TOLERANCES:
 - LENGTH AND HEIGHT = $\pm 1/4"$
 - STRUCTURAL THICKNESS = $\pm 1/4"$, -0"
 - HORIZONTAL SWEEP = $\pm 1/2"$
 - VERTICAL CAMBER = $\pm 3/8"$, -0"
 - OUT OF SQUARE = $1/8"$ PER 10', WITH $3/8"$ MAX.

DRILLED SHAFT NOTES

- ITEM 509.2, DRILLED SHAFT SHALL INCLUDE CONCRETE, REINFORCING, ANCHOR RODS, WATER REPELLENT AND ALL HARDWARE AND INCIDENTAL MATERIAL NECESSARY FOR THE CONSTRUCTION OF THE DRILLED SHAFTS AS SHOWN ON THE PLANS AND SPECIAL PROVISIONS.
- DRILLED SHAFT CONSTRUCTION METHODS, CONCRETE, AND REINFORCING REQUIREMENTS SHALL BE IN ACCORDANCE WITH THE SECTION 509 SPECIAL PROVISION.
- WHERE FILL EMBANKMENT IS TO BE CONSTRUCTED ABOVE THE EXISTING GROUND, THE EMBANKMENT SHALL BE BUILT PRIOR TO CONSTRUCTING THE SHAFTS. PLACEMENT AND COMPACTION OF THE FILL SHALL BE IN ACCORDANCE WITH SECTION 203.
- SEE PRECAST CONCRETE SOUNDWALL SHEET (4 OF 4) IF BEDROCK IS ENCOUNTERED.
- CONCRETE FOR THE DRILLED SHAFTS SHALL HAVE A MINIMUM 28 DAY COMPRESSIVE STRENGTH OF 3,000 PSI CLASS A CONCRETE AND SHALL CONFORM TO SECTION 520 UNLESS NOTED OTHERWISE.
- ALL REINFORCING STEEL SHALL CONFORM TO AASHTO M 31, GRADE 60. ALL REINFORCING STEEL SHALL BE A MINIMUM OF 3" CLEAR FROM CONCRETE SURFACES UNLESS NOTED OTHERWISE.
- COAT CONCRETE SURFACES OF THE DRILLED SHAFTS TO 1'-0" BELOW FINISHED GRADE WITH WATER REPELLENT (SILANE-SILOXANE) IN ACCORDANCE WITH SECTION 534. ALL COSTS SUBSIDIARY TO ITEM 509.2, DRILLED SHAFT.

TO BE COMPLETED BY DESIGNER:

SUMMARY OF SOUNDWALL QUANTITIES

ITEM NO.	ITEM DESCRIPTION	SOUNDWALL LOCATION & QUANTITY			UNIT
		WALL 1	WALL 2	WALL 3	
509.1	MOBILIZATION AND DEMOBILIZATION OF DRILLED SHAFT DRILLING EQUIPMENT				UNIT
509.2	DRILLED SHAFT				LF
509.3	OBSTRUCTION REMOVAL				LF
509.4	ROCK SOCKET EXCAVATION				LF
529.6	PRECAST CONCRETE SOUND ABATEMENT WALL (F)				SF

NOTES TO DESIGNER:

- THE SOUND ABATEMENT WALL AND DRILLED SHAFTS DETAILED ON THESE PLANS HAVE BEEN DESIGNED IN ACCORDANCE WITH THE DESIGN CRITERIA NOTED ON THIS SHEET. IT IS THE DESIGNER'S RESPONSIBILITY TO DETERMINE THE SUITABILITY OF THESE DETAILS FOR EACH PROJECT BASED ON PROJECT SPECIFIC INFORMATION. IF A REDESIGN IS REQUIRED, NEW DETAILS SHALL BE DEVELOPED AND STAMPED BY A PROFESSIONAL ENGINEER LICENSED IN THE STATE OF NEW HAMPSHIRE. THE TITLE BLOCK SHALL BE UPDATED WITH DESIGNER'S INITIALS.
- THE SOUND ABATEMENT WALL FOUNDATION SHALL BE DESIGNED (DRILLED SHAFT AND ROCK SOCKET LENGTHS) FOR EACH PROJECT BASED ON PROJECT SPECIFIC INFORMATION. THE DESIGNER SHALL WORK CLOSELY WITH THE GEOTECHNICAL ENGINEER FOR THE DESIGN OF THE DRILLED SHAFT FOUNDATIONS.
- THE DESIGNER SHALL COMPLETE PLAN SHEETS THAT INCLUDE A SOUNDWALL LOCATION CHART AND WALL LAYOUT DETAILS SUCH AS ELEVATION, SECTION, AND PLAN VIEWS. THE DESIGNER SHALL DETERMINE THE LOWER SURROUNDING GROUND ELEVATION AND LAYOUT POST LOCATIONS BASED ON THE MAXIMUM POST SPACING SHOWN IN THE TABLE BELOW.
- THE TOP OF WALL ELEVATIONS NOTED IN THE SOUNDWALL NOISE STUDY MAY REQUIRE ADJUSTMENT TO MAINTAIN THE 12" MAX. ELEVATION CHANGE FROM THE POST TO THE NEXT PANEL AS SHOWN ON SHEET 2 OF 4.
- WHEN WALL HEIGHT IS DIFFERENT BETWEEN ADJACENT SEGMENTS, USE HIGHER VALUE FOR SELECTION OF POSTS, BASE PLATES, FOUNDATIONS, ANCHOR BOLTS, AND POST SPACING.
- IF A REDUCED POST SPACING IS USED, THE DESIGNER SHALL CLEARLY NOTE THE REDUCED SPACING ON THE SOUNDWALL LAYOUT SHEETS SO THE FABRICATOR CAN ADJUST THE PANEL LENGTHS AS NEEDED.

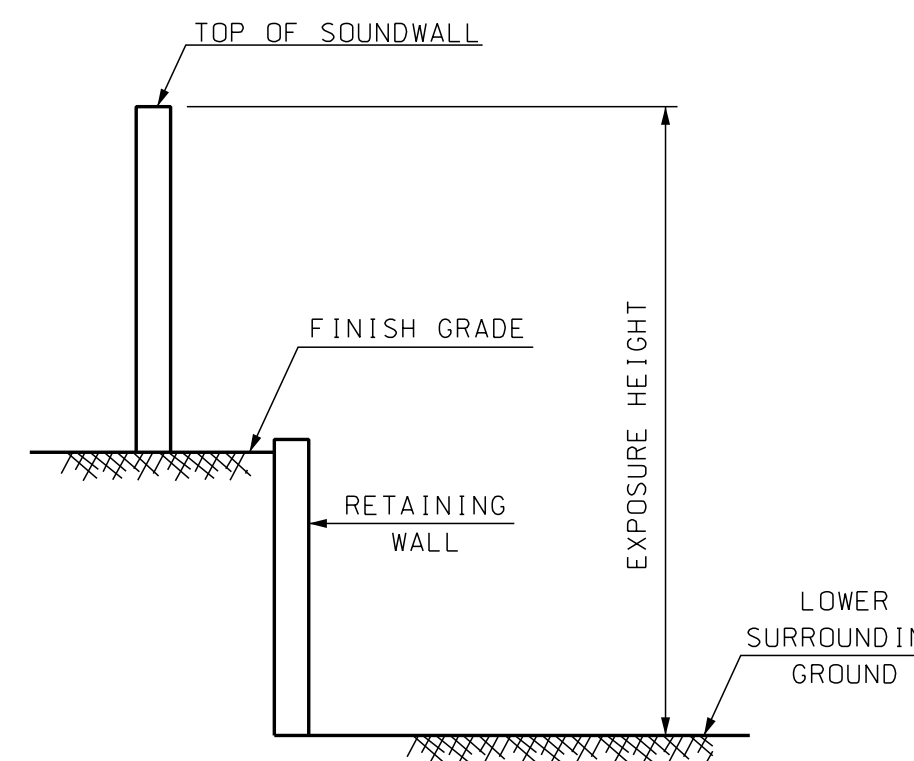

SECTION - RETAINING WALL

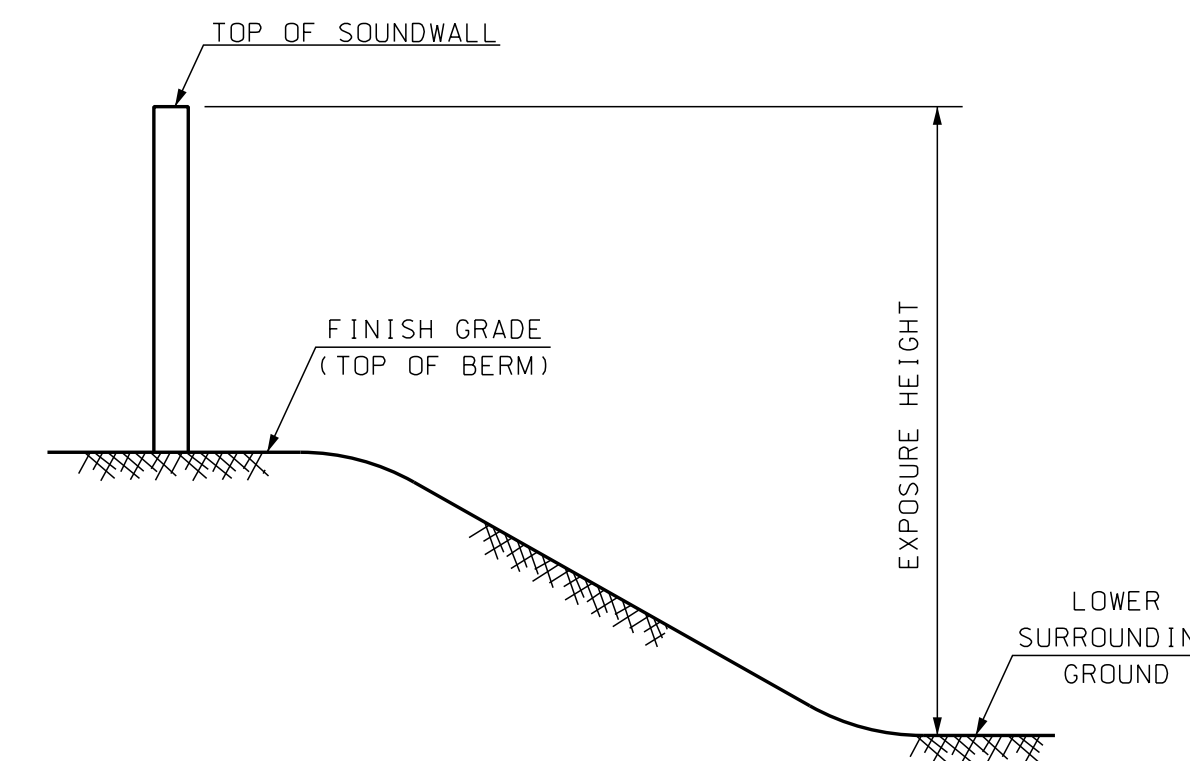

SECTION - BERM

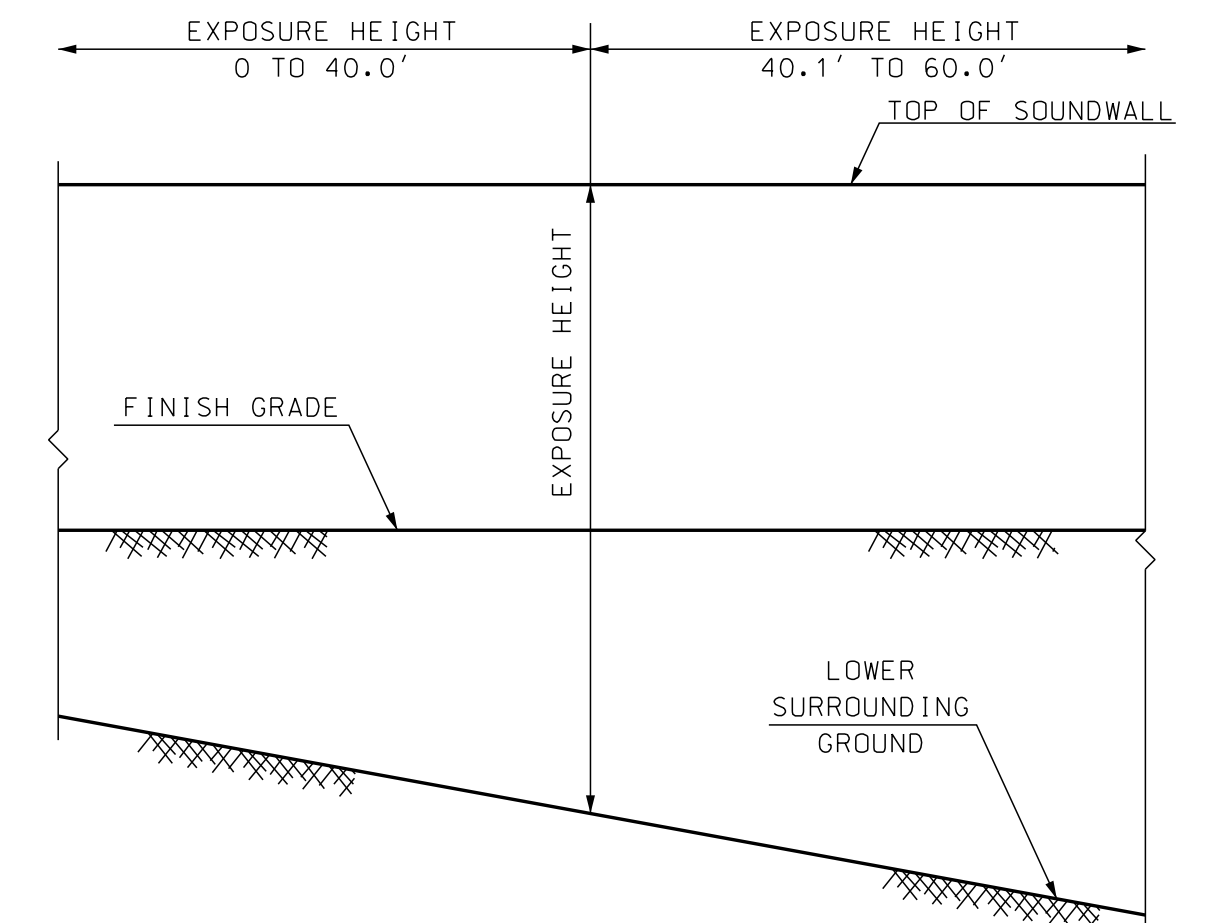

ELEVATION

MAXIMUM POST SPACING AND EXPOSURE HEIGHT DETAIL

MAXIMUM POST SPACING TABLE	
(SEE GENERAL NOTE 6)	
EXPOSURE HEIGHT	MAX. POST SPACING
0 TO 40.0'	20'-0"
40.1' TO 60.0'	18'-0"

SUBDIRECTORY	DGN LOCATOR	SHEET SCALE
English/SNDWALL	SOUNDWALL (1 OF 4)	AS NOTED

STATE OF NEW HAMPSHIRE						
DEPARTMENT OF TRANSPORTATION * BUREAU OF BRIDGE DESIGN						
TOWN		BRIDGE NO.		STATE PROJECT		
LOCATION						BRIDGE SHEET
PRECAST CONCRETE SOUNDWALL (1 OF 4)						OF
REVISIONS AFTER PROPOSAL		BY	DATE	BY	DATE	FILE NUMBER
		DESIGNED	VHB	11/2022	CHECKED	JGM/LRL
		DRAWN	BJM	11/2022	CHECKED	JGM/LRL
		QUANTITIES		CHECKED		
		ISSUE DATE	12/21/2022	FEDERAL PROJECT NO.		SHEET NO.
		REV. DATE				TOTAL SHEETS

NO MODIFICATIONS SHALL BE MADE TO THIS SHEET, EXCEPT AS NOTED IN CLOUDS. IF ANY MODIFICATIONS ARE MADE TO THIS SHEET, THAT PERSON SHALL BECOME THE DESIGNER AND ENGINEER OF RECORD.

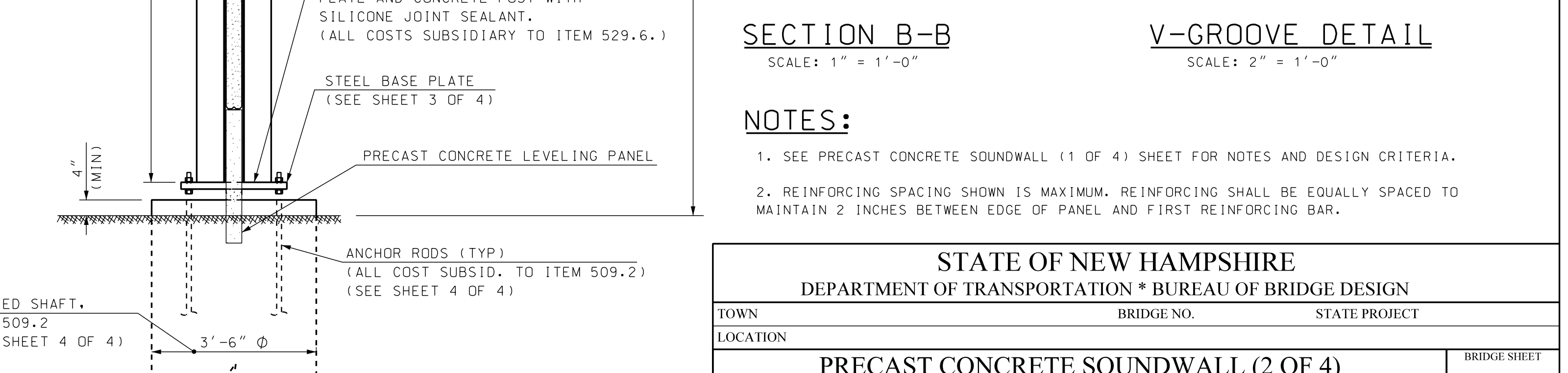
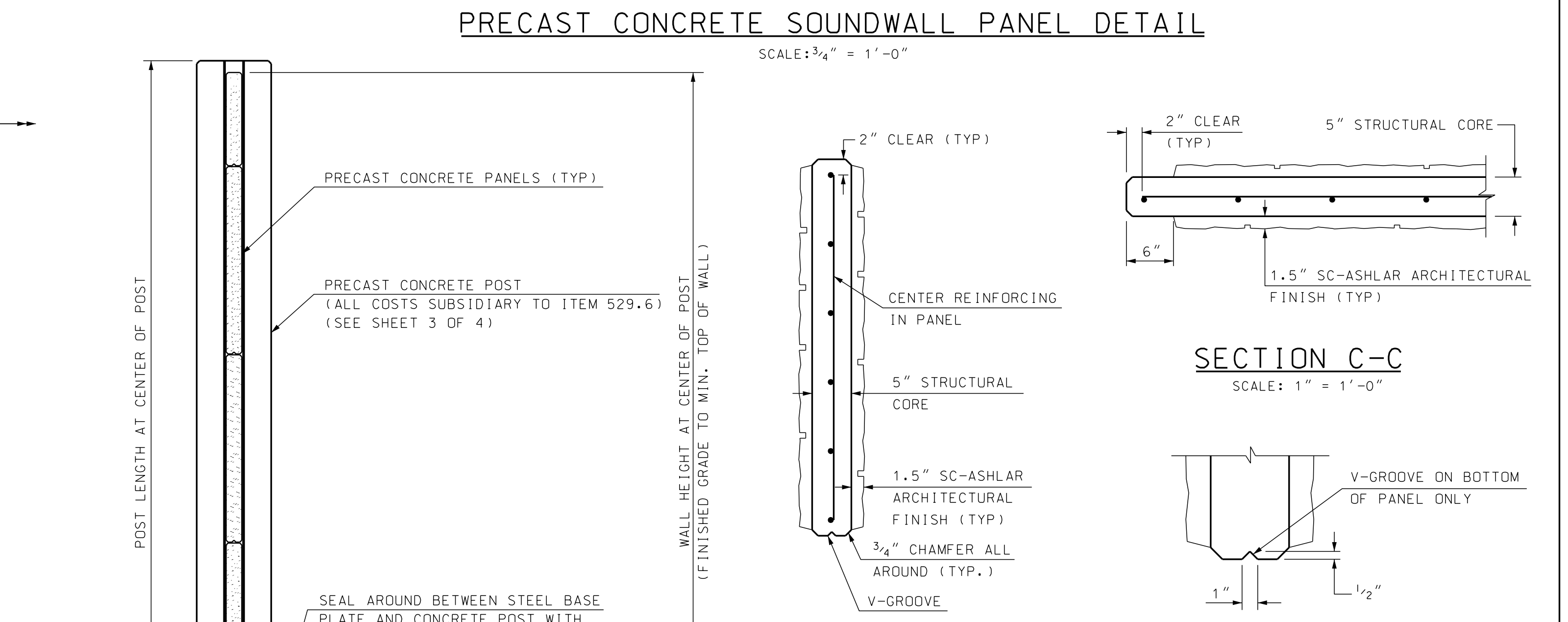
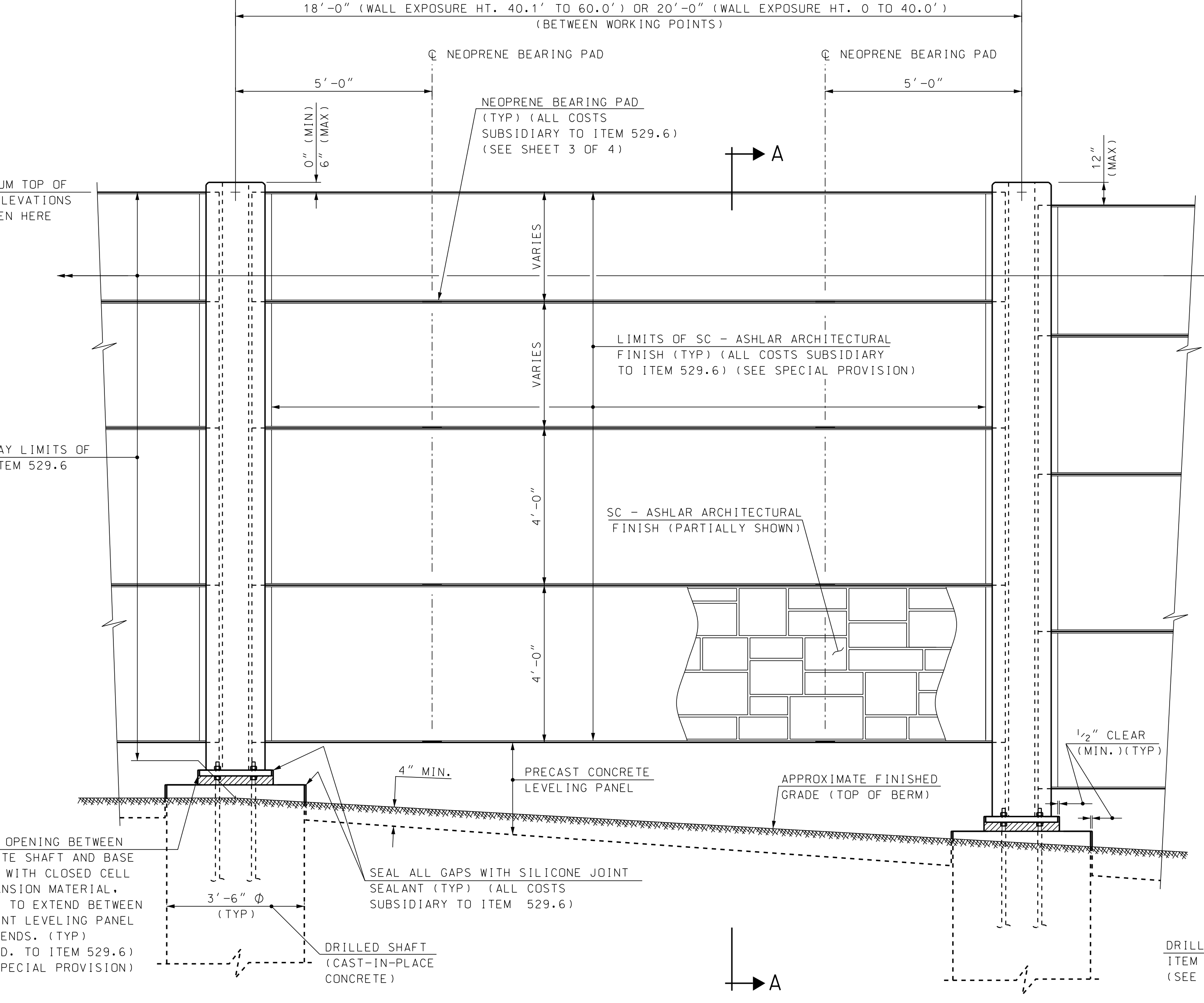
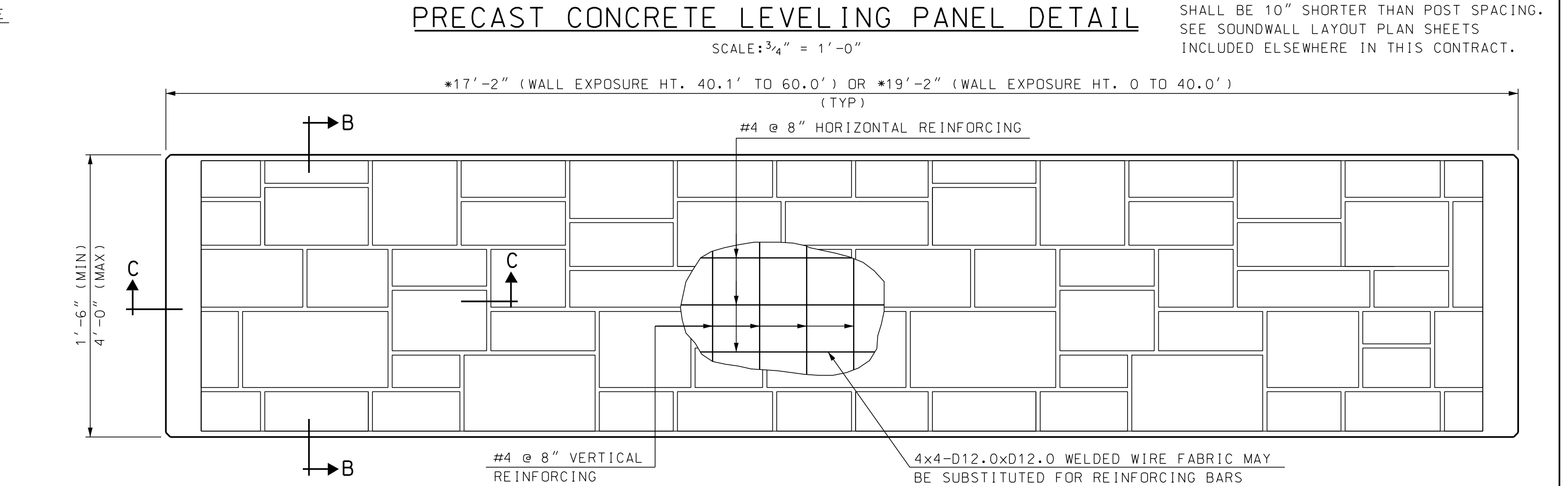
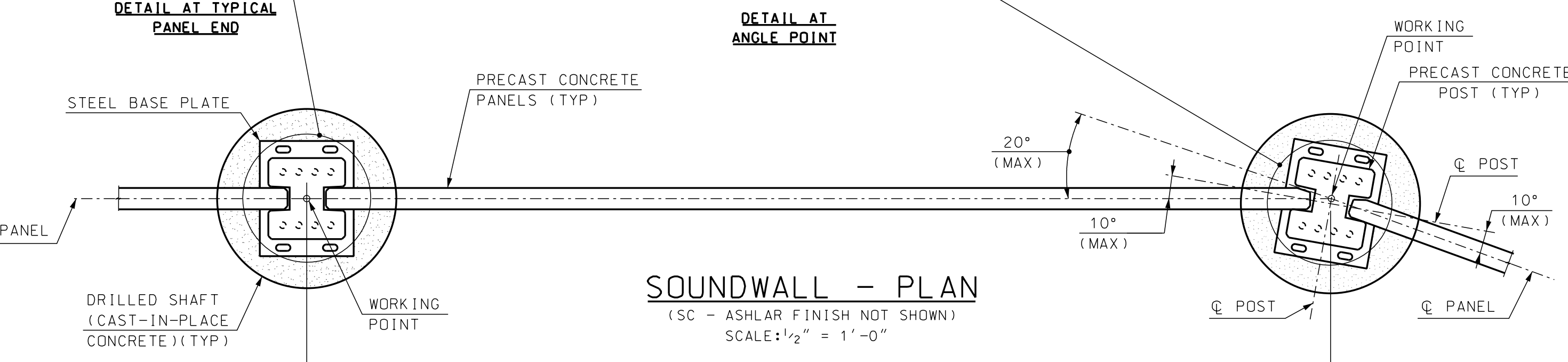
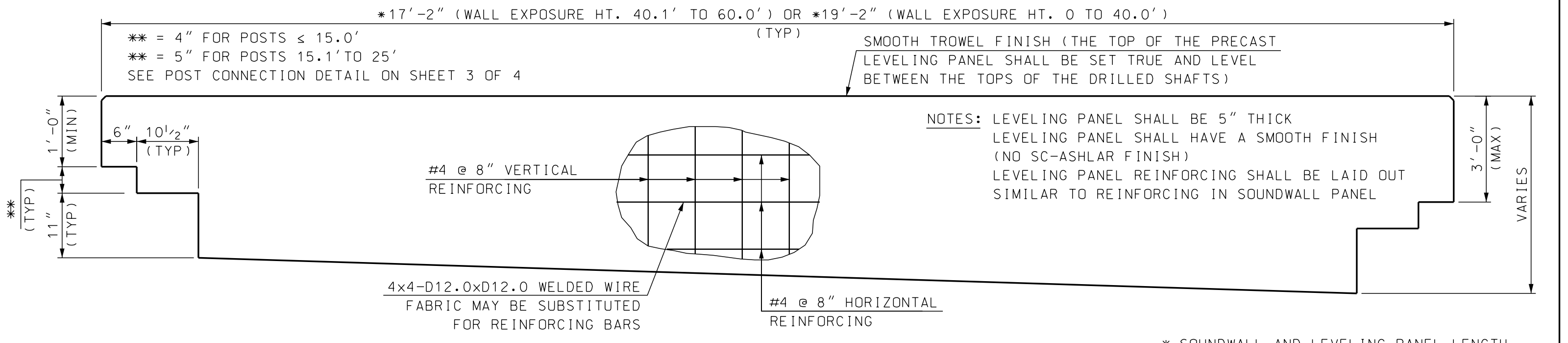
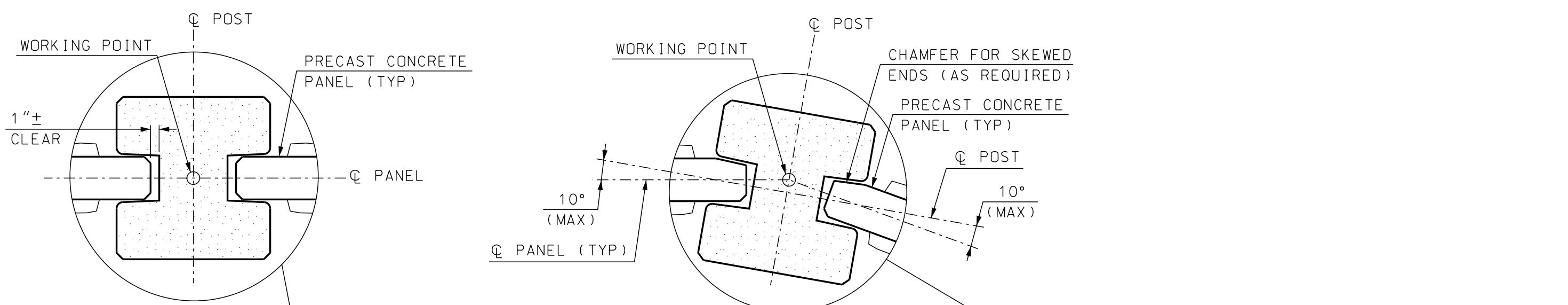

NO MODIFICATIONS SHALL BE MADE TO THIS SHEET, IF ANY MODIFICATIONS ARE MADE TO THIS SHEET, THAT PERSON SHALL BECOME THE DESIGNER AND ENGINEER OF RECORD.

SOUNDWALL - ELEVATION
(SC - ASHLAR FINISH PARTIALLY SHOWN)
SCALE: 1/2" = 1'-0"

SECTION A-A
(SC - ASHLAR FINISH NOT SHOWN)
SCALE: 1/2" = 1'-0"

- NOTES:**
- SEE PRECAST CONCRETE SOUNDWALL (1 OF 4) SHEET FOR NOTES AND DESIGN CRITERIA.
 - REINFORCING SPACING SHOWN IS MAXIMUM. REINFORCING SHALL BE EQUALLY SPACED TO MAINTAIN 2 INCHES BETWEEN EDGE OF PANEL AND FIRST REINFORCING BAR.

STATE OF NEW HAMPSHIRE											
DEPARTMENT OF TRANSPORTATION * BUREAU OF BRIDGE DESIGN											
TOWN		BRIDGE NO.				STATE PROJECT					
LOCATION											
PRECAST CONCRETE SOUNDWALL (2 OF 4)										BRIDGE SHEET	
REVISIONS AFTER PROPOSAL		BY		DATE		BY		DATE		OF	
		DESIGNED		VHB		11/2022		CHECKED		JGM	
		DRAWN		BJM		11/2022		CHECKED		JGM/LRL	
		QUANTITIES						CHECKED			
		ISSUE DATE		12/21/2022		FEDERAL PROJECT NO.				SHEET NO.	
		REV. DATE		1/17/2023						TOTAL SHEETS	
SUBDIRECTORY		DGN LOCATOR		SHEET SCALE							
English/SNDWALL		SOUNDWALL (2 OF 4)		AS NOTED							

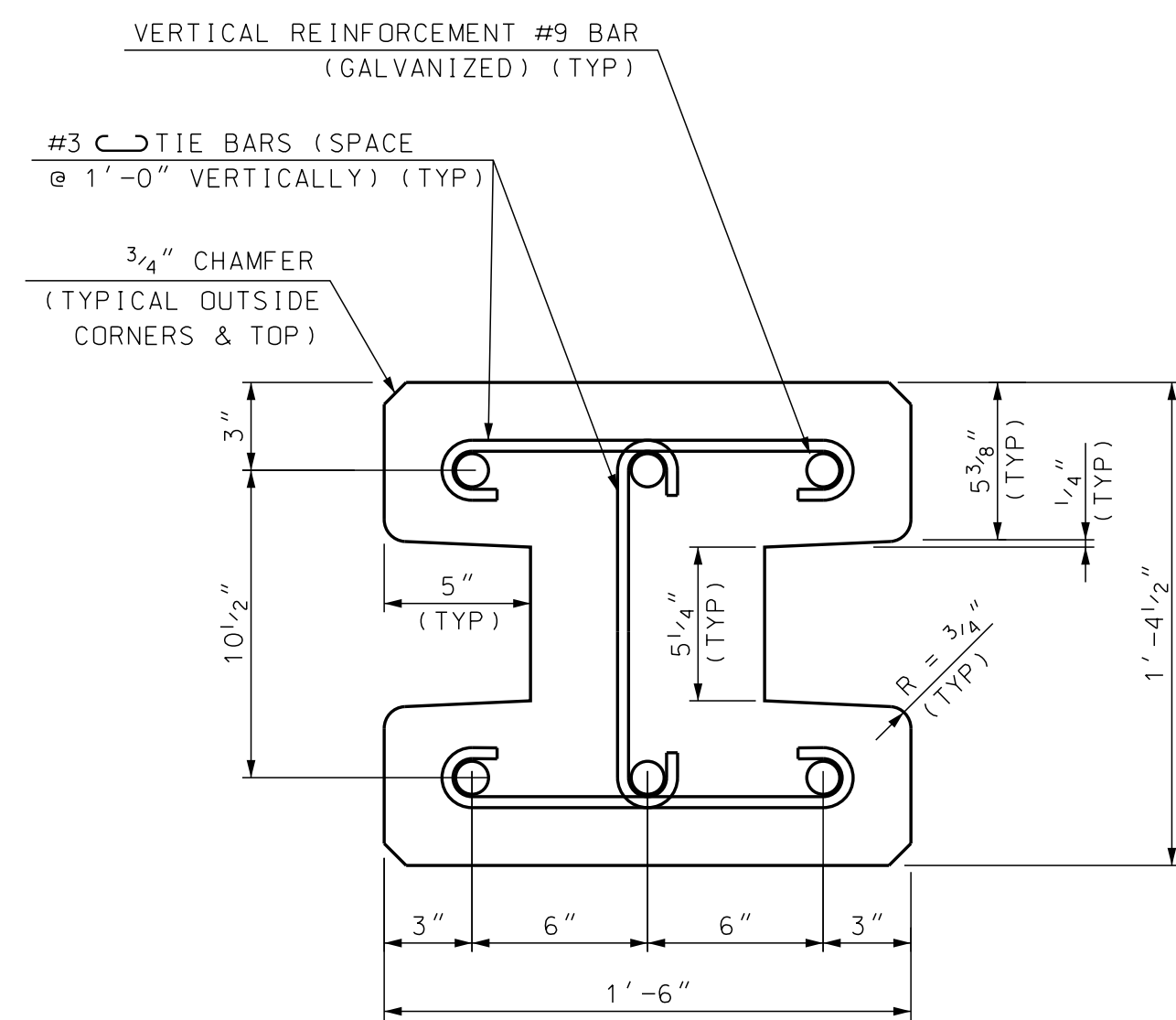

POST SECTION DETAIL
FOR POST LENGTHS $\leq 15.0'$
SCALE: 2" = 1'-0"

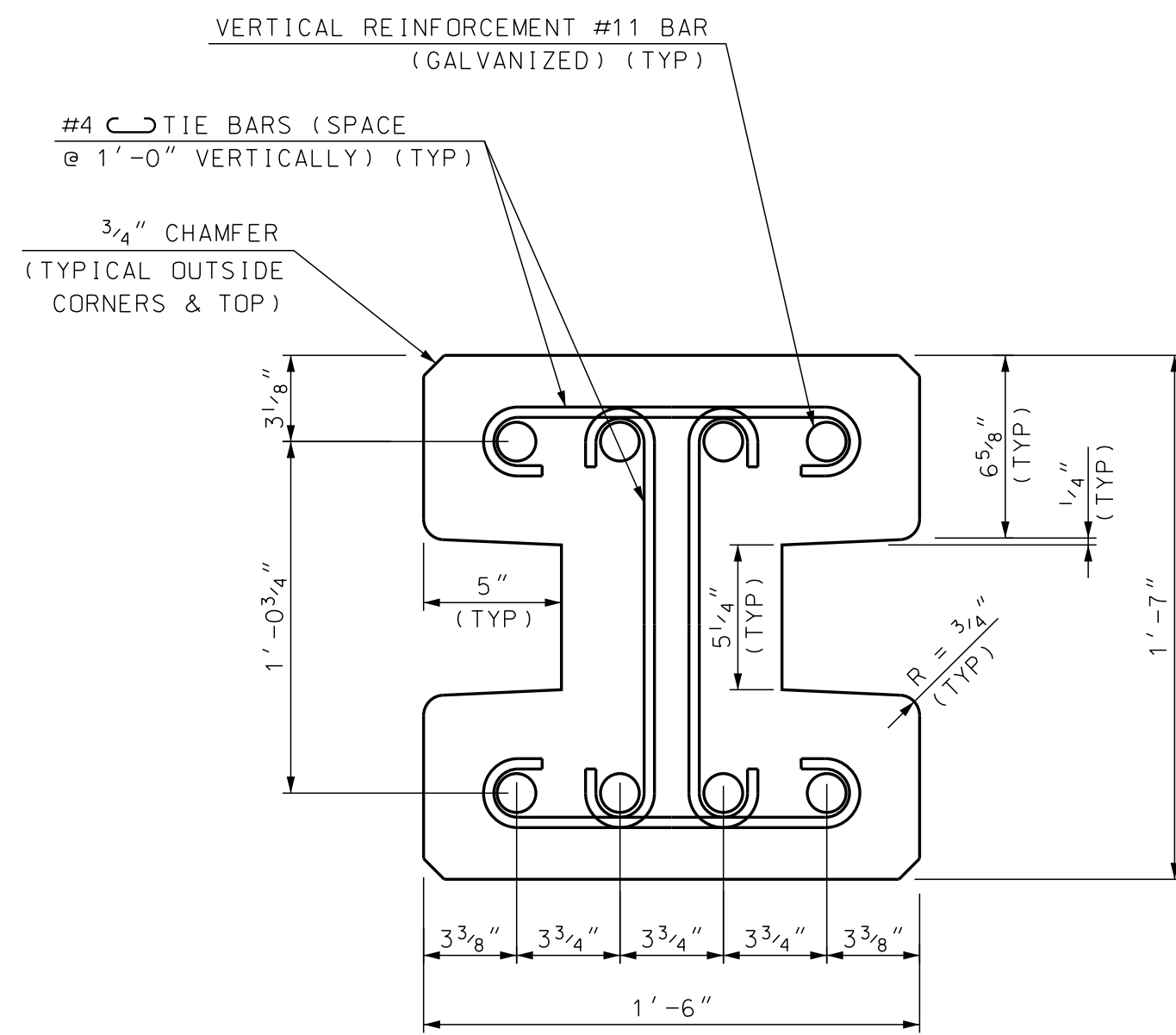

POST SECTION DETAIL
FOR POST LENGTHS 15.1' TO 25.0'
SCALE: 2" = 1'-0"

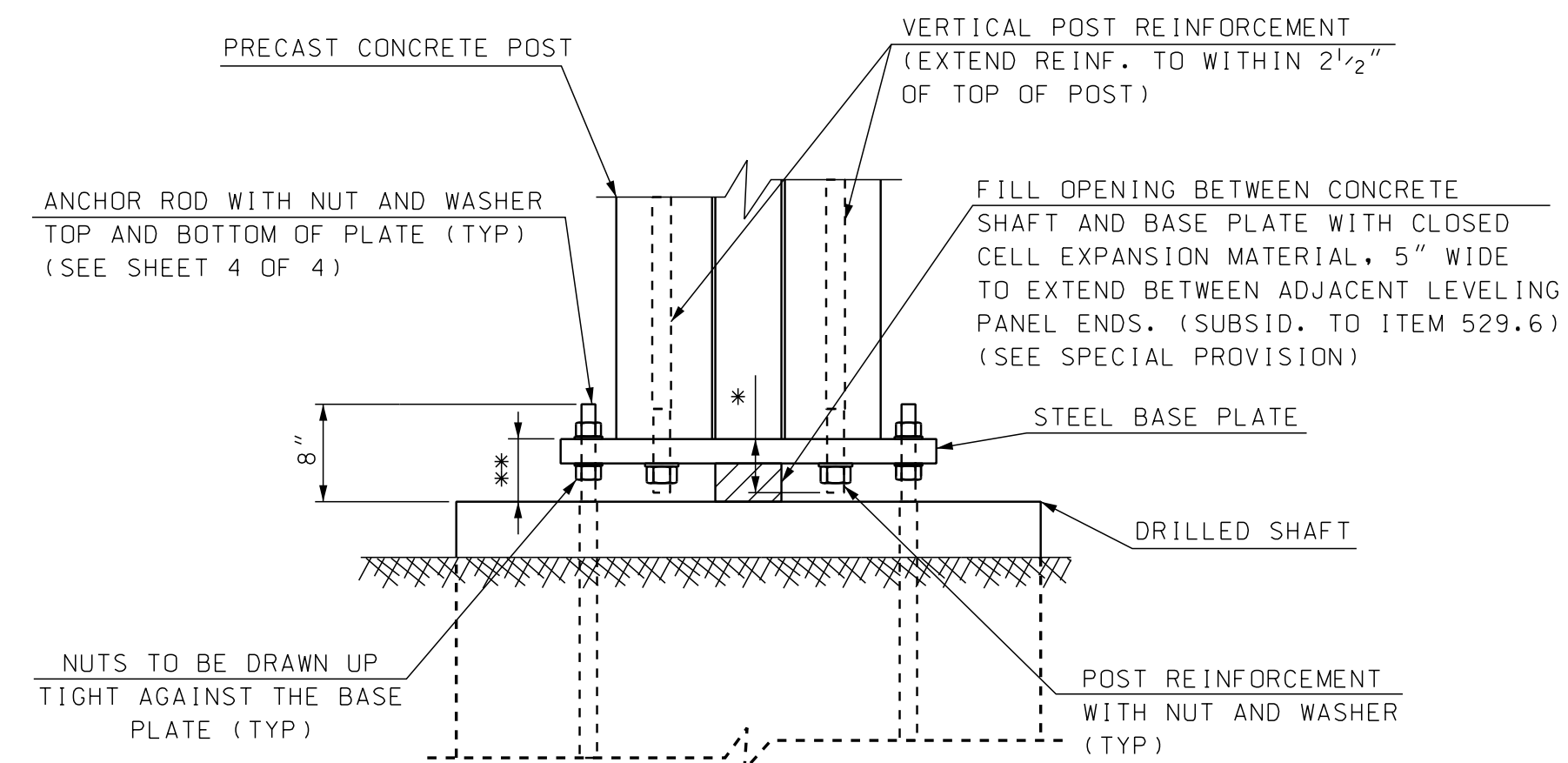

* THREADS OF THE VERTICAL POST REINFORCEMENT SHALL EXTEND BEYOND THE BOTTOM OF THE POST:
3 1/2" FOR POSTS $\leq 15.0'$
4 1/2" FOR POSTS 15.1' TO 25.0'
THE LAST 5" OF THE VERTICAL POST REINFORCEMENT SHALL BE THREADED FOR BOTH POSTS.

** DISTANCE BETWEEN TOP OF DRILLED SHAFT AND TOP OF BASE PLATE:
4" FOR POSTS $\leq 15.0'$
5" FOR POSTS 15.1' TO 25.0'

CUT THREAD SIZES SHALL BE : 1" - 8 UNC FOR #9 BARS
1 1/4" - 8 UN FOR #11 BAR

POST CONNECTION DETAIL
SCALE: 1" = 1'-0"

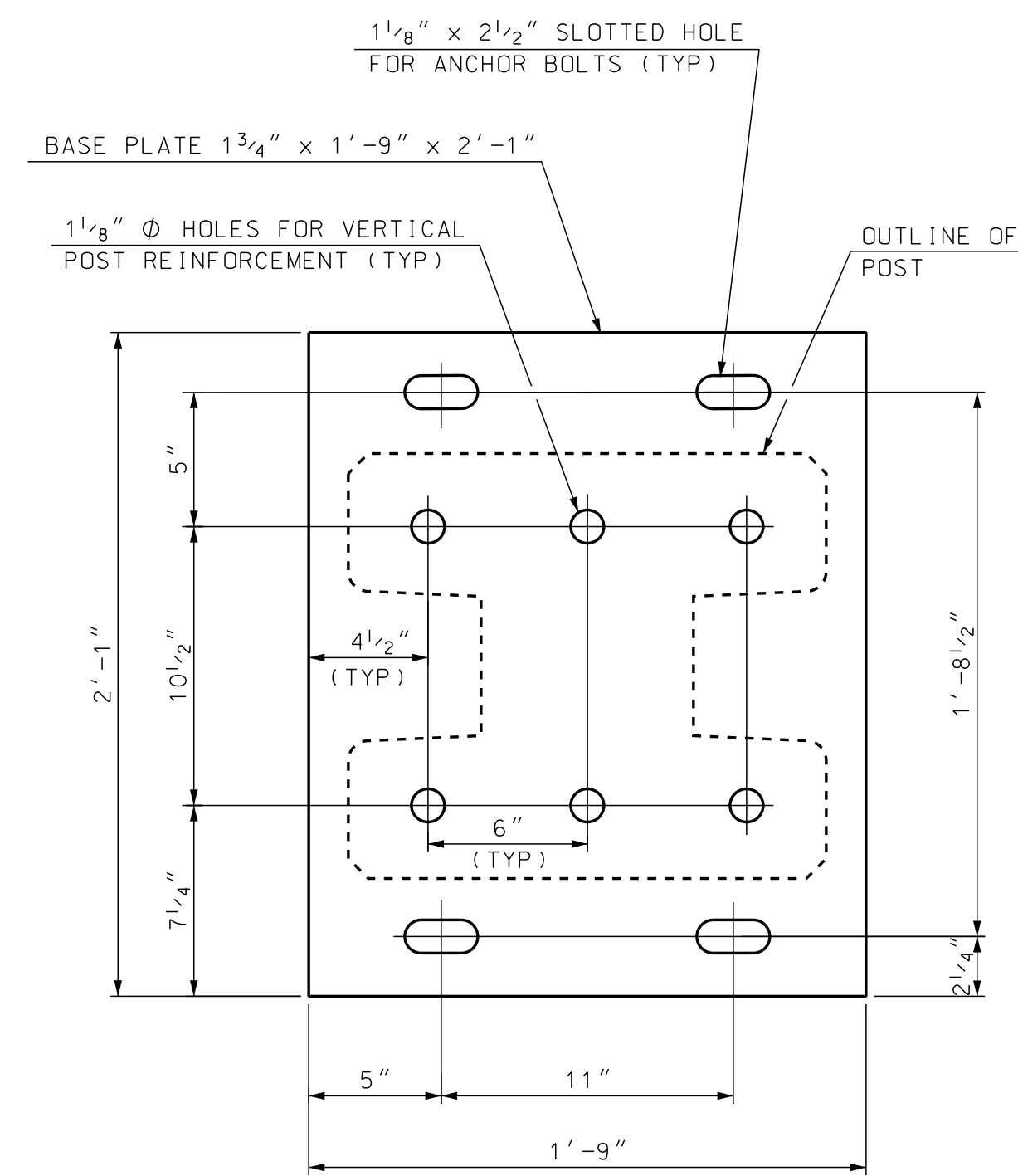

POST BASE PLATE DETAIL
FOR POST LENGTHS $\leq 15.0'$
SCALE: 2" = 1'-0"

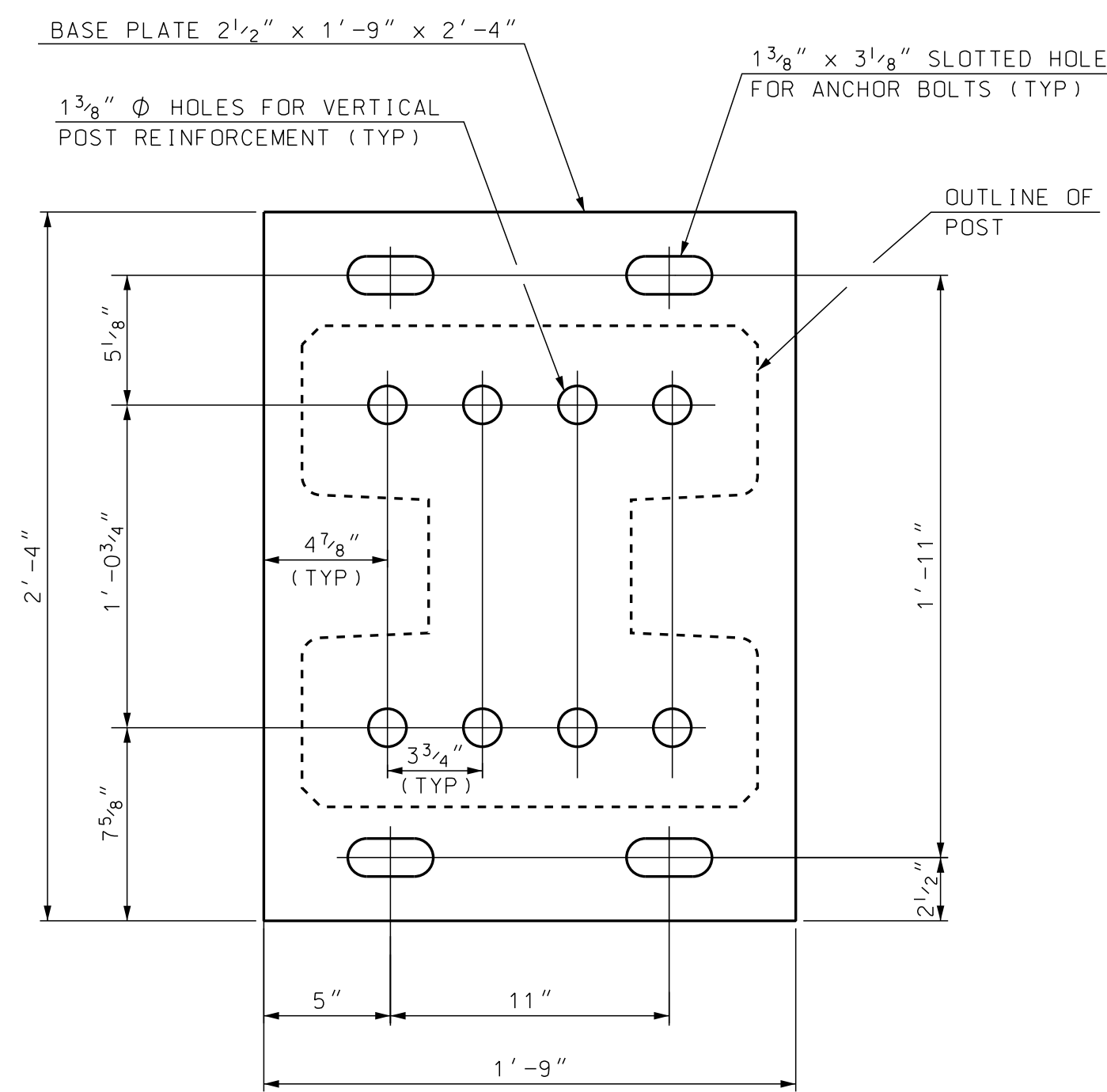

POST BASE PLATE DETAIL
FOR POST LENGTHS 15.1' TO 25.0'
SCALE: 2" = 1'-0"

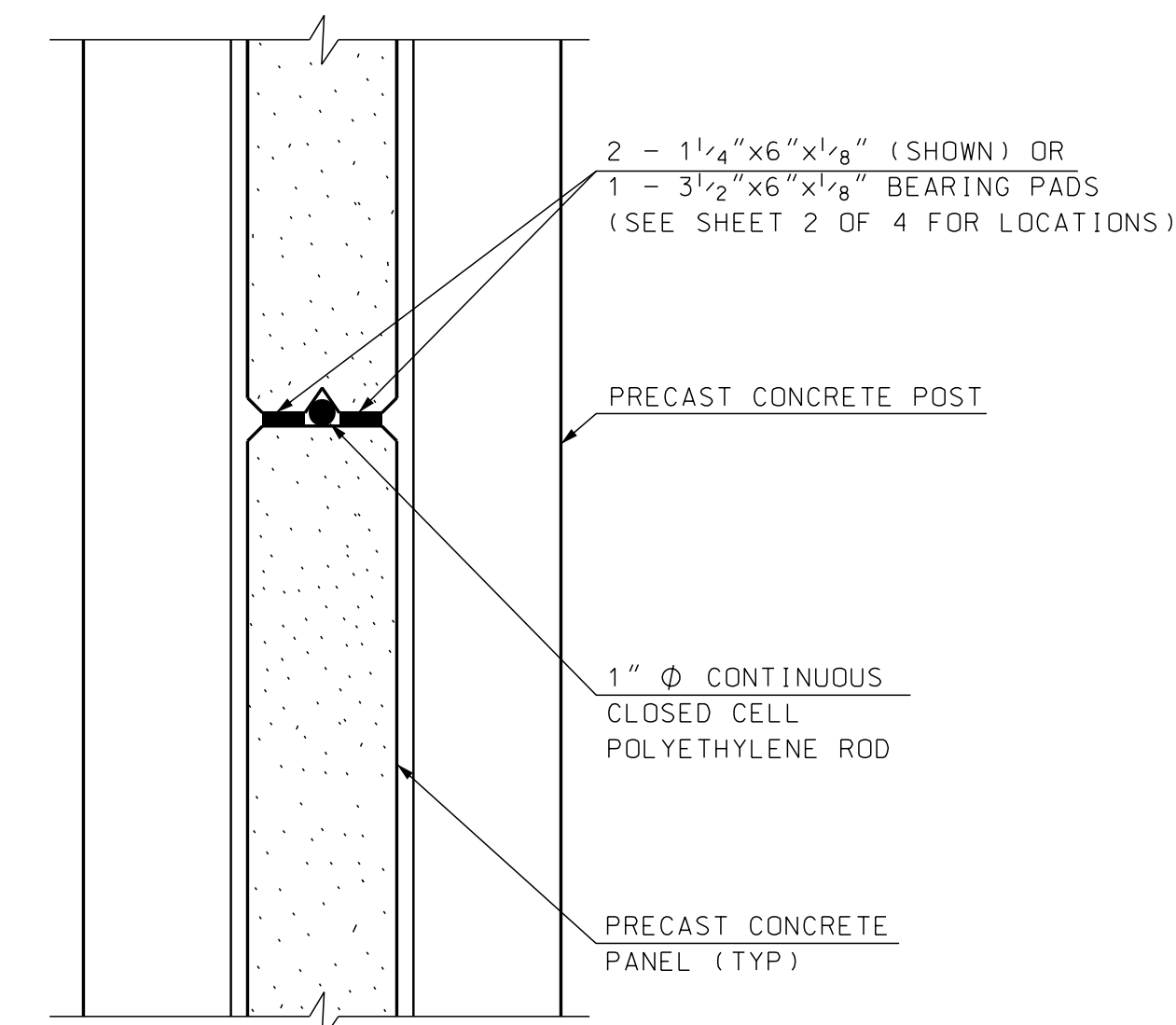

PANEL JOINT DETAIL
(SC - ASHLAR ARCHITECTURAL FINISH NOT SHOWN)
SCALE: 2" = 1'-0"

NOTES:

- SEE PRECAST CONCRETE SOUNDWALL (1 OF 4) SHEET FOR NOTES AND DESIGN CRITERIA.
- POLYETHYLENE ROD AND BEARING PADS SHALL BE ATTACHED TO BOTTOM OF PANEL USING SPRAY ADHESIVE OR SIMILAR DURING ERECTION.

NO MODIFICATIONS SHALL BE MADE TO THIS SHEET. IF ANY MODIFICATIONS ARE MADE TO THIS SHEET, THAT PERSON SHALL BECOME THE DESIGNER AND ENGINEER OF RECORD.

STATE OF NEW HAMPSHIRE									
DEPARTMENT OF TRANSPORTATION * BUREAU OF BRIDGE DESIGN									
TOWN		BRIDGE NO.			STATE PROJECT				
LOCATION									
PRECAST CONCRETE SOUNDWALL (3 OF 4)								BRIDGE SHEET	
REVISIONS AFTER PROPOSAL								OF	
DESIGNED		BY		DATE		BY		DATE	
DRAWN		BY		DATE		BY		DATE	
QUANTITIES		BY		DATE		BY		DATE	
ISSUE DATE		FEDERAL PROJECT NO.		SHEET NO.		TOTAL SHEETS			
REV. DATE									
English/SNDWALL	DGN LOCATOR	SOUNDWALL (3 OF 4)	SHEET SCALE	AS NOTED					

NO MODIFICATIONS SHALL BE MADE TO THIS SHEET, EXCEPT AS NOTED IN CLOUDS. IF ANY MODIFICATIONS ARE MADE TO THIS SHEET, THAT PERSON SHALL BECOME THE DESIGNER AND ENGINEER OF RECORD.

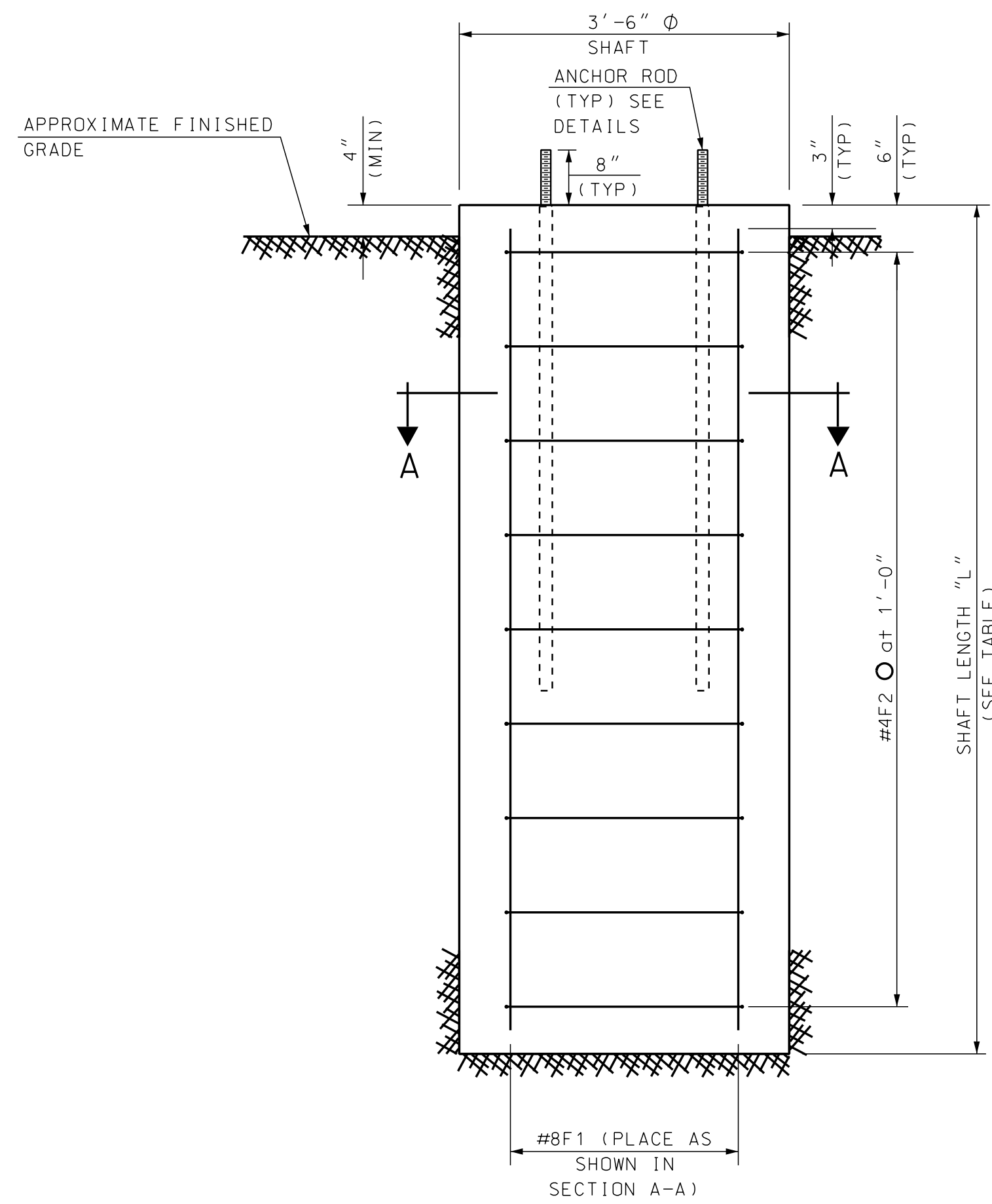

ELEVATION - DRILLED SHAFT IN SOIL
SCALE: 3/4" = 1'-0"

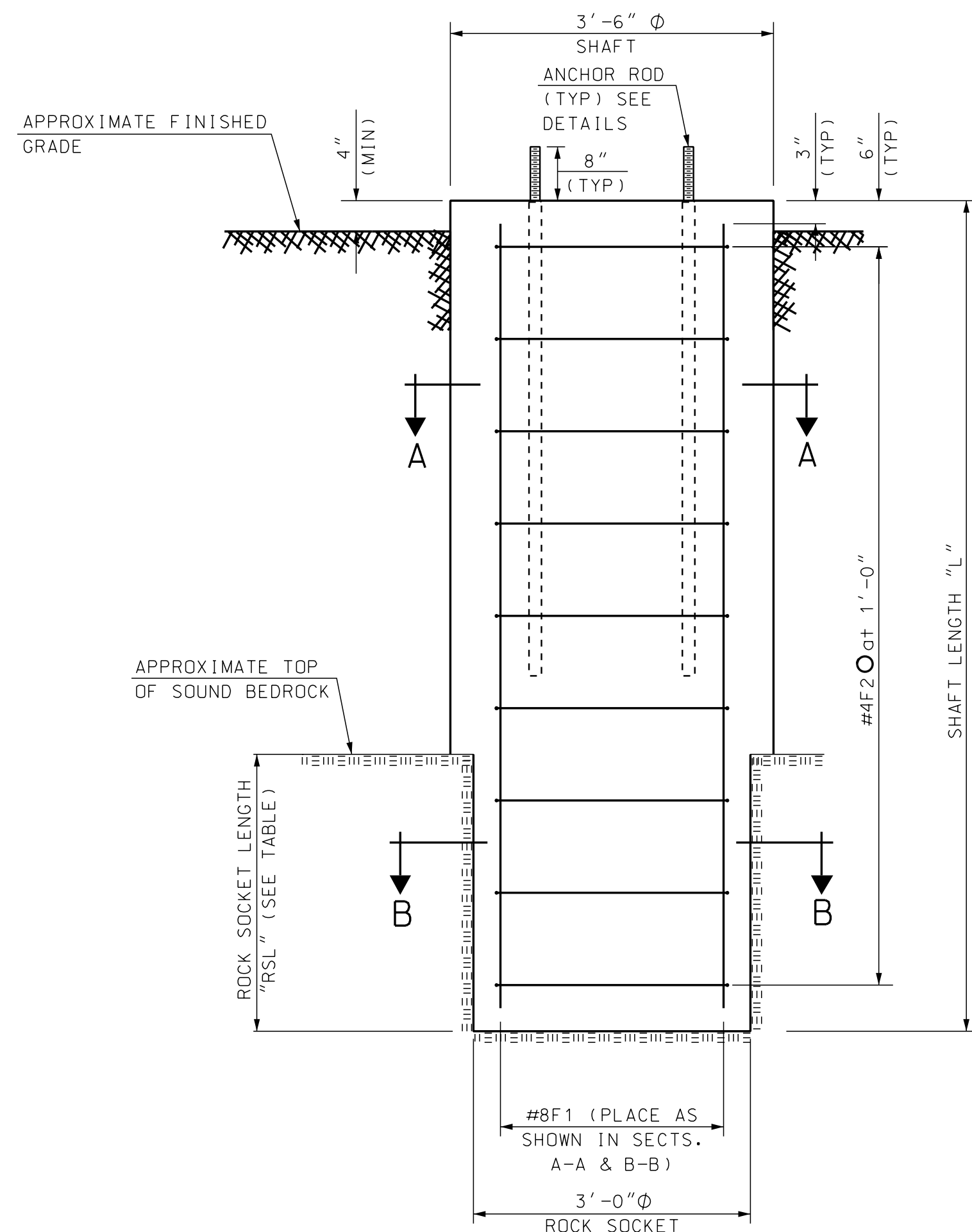

ELEVATION - DRILLED SHAFT IN ROCK
SCALE: 3/4" = 1'-0"

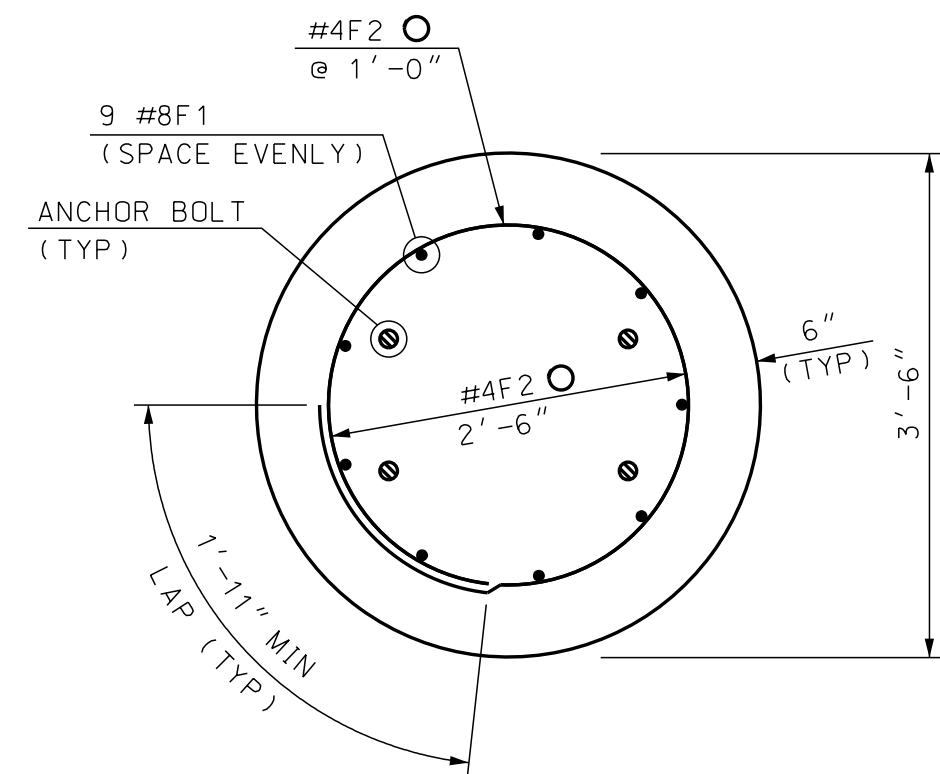

SECTION A-A
(IN SOIL)
SCALE: 3/4" = 1'-0"

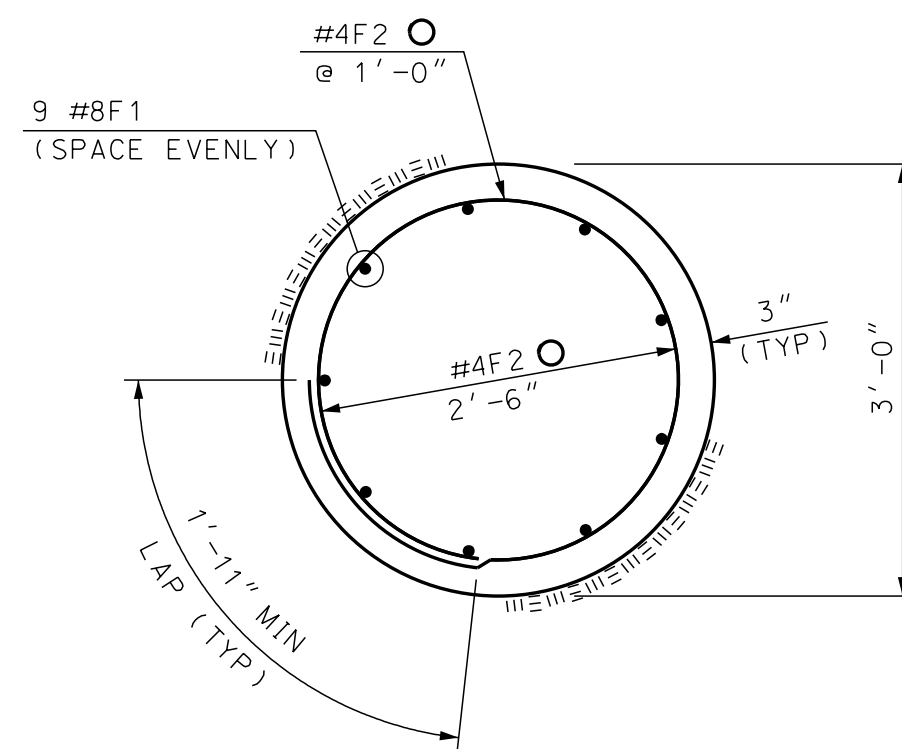

SECTION B-B
(IN ROCK)
SCALE: 3/4" = 1'-0"

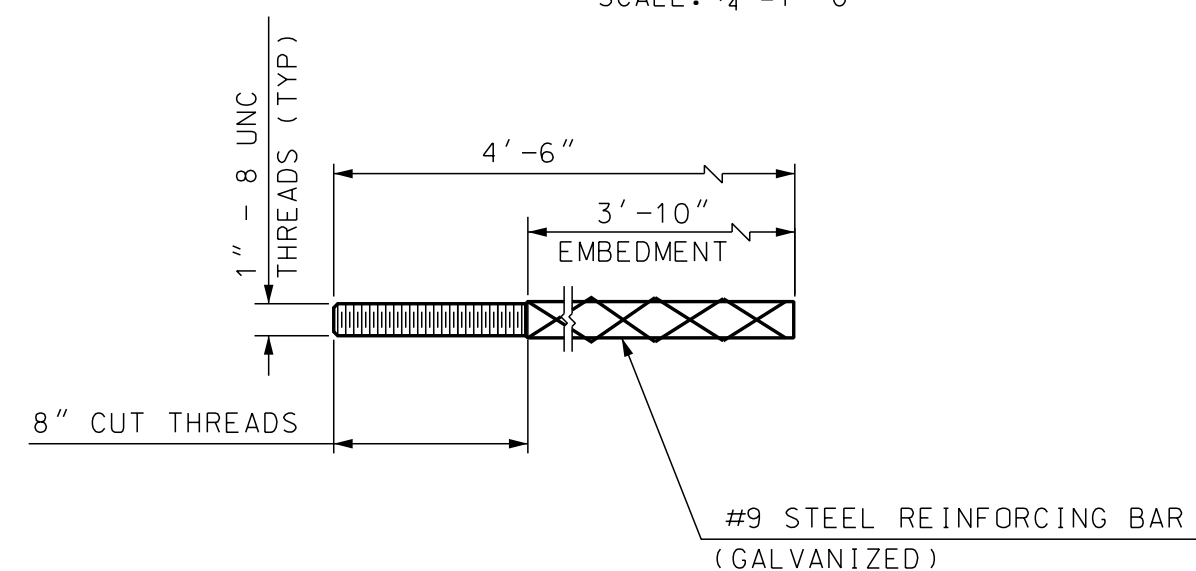

ANCHOR ROD DETAIL
FOR POST LENGTH ≤ 15.0'
NOT TO SCALE

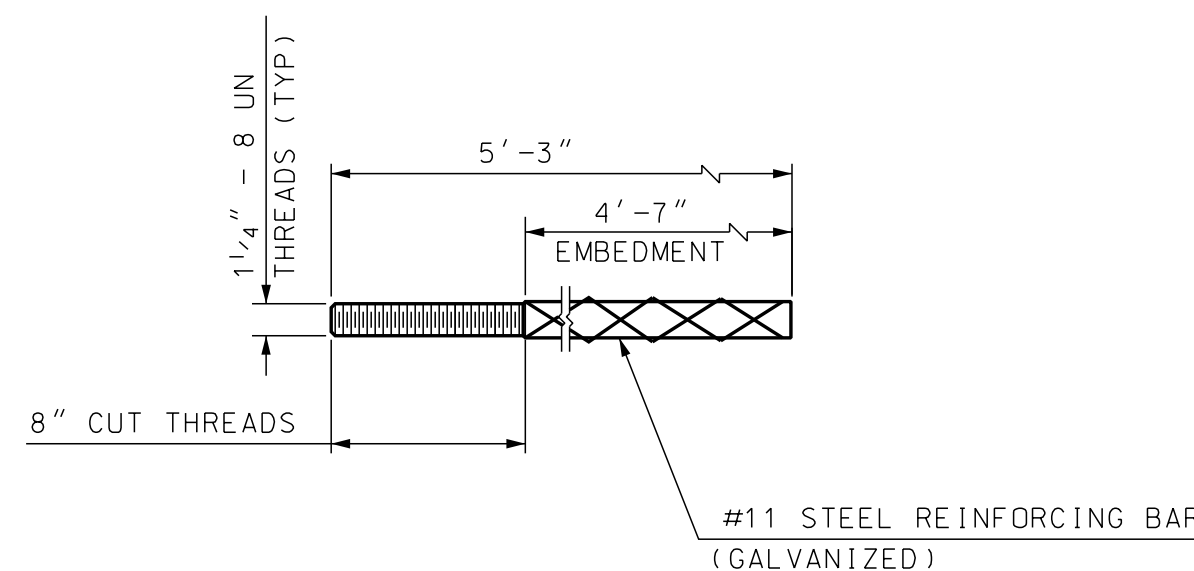

ANCHOR ROD DETAIL
FOR POST LENGTH 15.1' TO 25.0'
NOT TO SCALE

TO BE COMPLETED BY DESIGNER:

SHAFT LENGTH SUMMARY TABLES

(FOR POST/SHAFT NUMBERS SEE PLAN SHEETS INCLUDED ELSEWHERE IN THIS CONTRACT)

WALL 1

POST/SHAFT NUMBERS	SHAFT LENGTH "L"	ROCK SOCKET LENGTH "RSL"	NUMBER OF POSTS/SHAFTS
x TO xx	xx' - x"	xx' - x"	xx
xx TO xx	xx' - x"	xx' - x"	xx
xx TO xx	xx' - x"	xx' - x"	xx
xx TO xx	xx' - x"	xx' - x"	xx
xx TO xx	xx' - x"	xx' - x"	xx

WALL 2

POST/SHAFT NUMBERS	SHAFT LENGTH "L"	ROCK SOCKET LENGTH "RSL"	NUMBER OF POSTS/SHAFTS
x TO xx	xx' - x"	xx' - x"	xx
xx TO xx	xx' - x"	xx' - x"	xx
xx TO xx	xx' - x"	xx' - x"	xx
xx TO xx	xx' - x"	xx' - x"	xx
xx TO xx	xx' - x"	xx' - x"	xx

WALL 3

POST/SHAFT NUMBERS	SHAFT LENGTH "L"	ROCK SOCKET LENGTH "RSL"	NUMBER OF POSTS/SHAFTS
x TO xx	xx' - x"	xx' - x"	xx
xx TO xx	xx' - x"	xx' - x"	xx
xx TO xx	xx' - x"	xx' - x"	xx
xx TO xx	xx' - x"	xx' - x"	xx
xx TO xx	xx' - x"	xx' - x"	xx

ESTIMATED SHAFT QUANTITIES

(PER INSTALLED FOOT OF 3'-6" Ø SHAFT)

ITEM	UNIT	QUANTITY
CONCRETE CLASS A	CY/LF	0.36
REINFORCING STEEL	LB/LF	30.60

FOR INFORMATION ONLY. ALL COST INCLUDED IN ITEM 509.2.

SHAFT REINFORCING SCHEDULE

BAR MARK	SIZE	UNBENT LENGTH	TYPE
F1	#8	L-6"	—
F2	#4	9'-10"	○

NOTE:

1. SEE PRECAST CONCRETE SOUNDWALL (1 OF 4) SHEET FOR NOTES AND DESIGN CRITERIA.

STATE OF NEW HAMPSHIRE									
DEPARTMENT OF TRANSPORTATION * BUREAU OF BRIDGE DESIGN									
TOWN		BRIDGE NO.			STATE PROJECT				
LOCATION									
PRECAST CONCRETE SOUNDWALL (4 OF 4)								BRIDGE SHEET	
REVISIONS AFTER PROPOSAL		BY		DATE		BY		DATE	
		VHB		11/2022		JGM		11/2022	
		BJM		11/2022		JGM/LRL		11/2022	
		DESIGNED		CHECKED		QUANTITIES		FILE NUMBER	
		DRAWN		CHECKED		CHECKED			
		ISSUE DATE		FEDERAL PROJECT NO.		SHEET NO.		TOTAL SHEETS	
		12/21/2022							
		REV. DATE							
SUBDIRECTORY		DGN LOCATOR		SHEET SCALE					
English/SNDWALL		SOUNDWALL (4 OF 4)		AS NOTED					