

NOTE: REFER TO PAVEMENT LAYOUT PLANS AND CROSS-SECTIONS FOR DRIVEWAY LENGTHS, WIDTHS, RADII, CURB CUTS, GRADES AND PAVEMENT & BASE COURSE DEPTHS

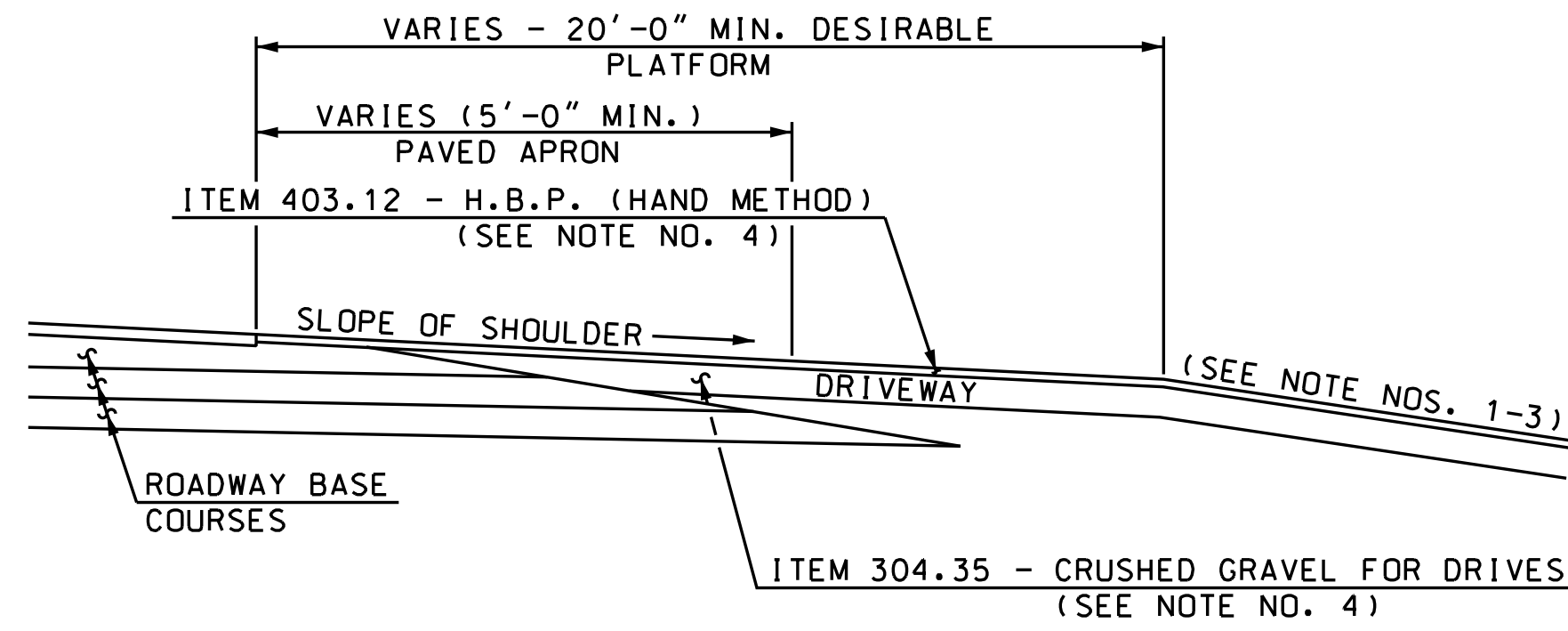

TYPICAL UNCURBED DRIVE IN FILL SECTION

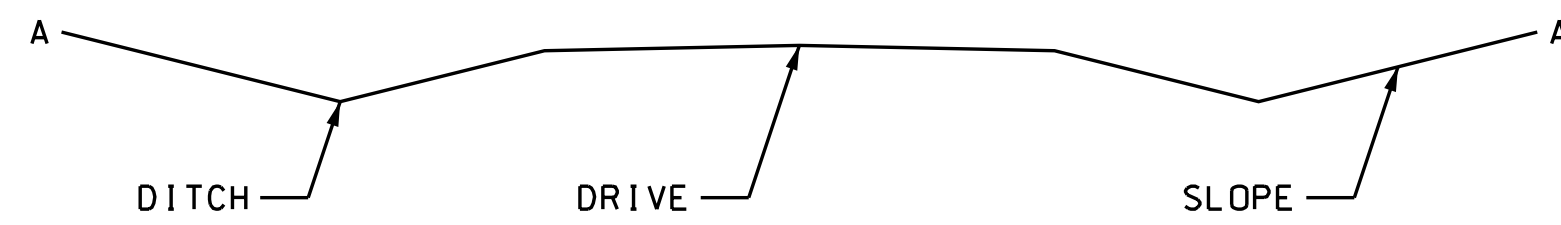
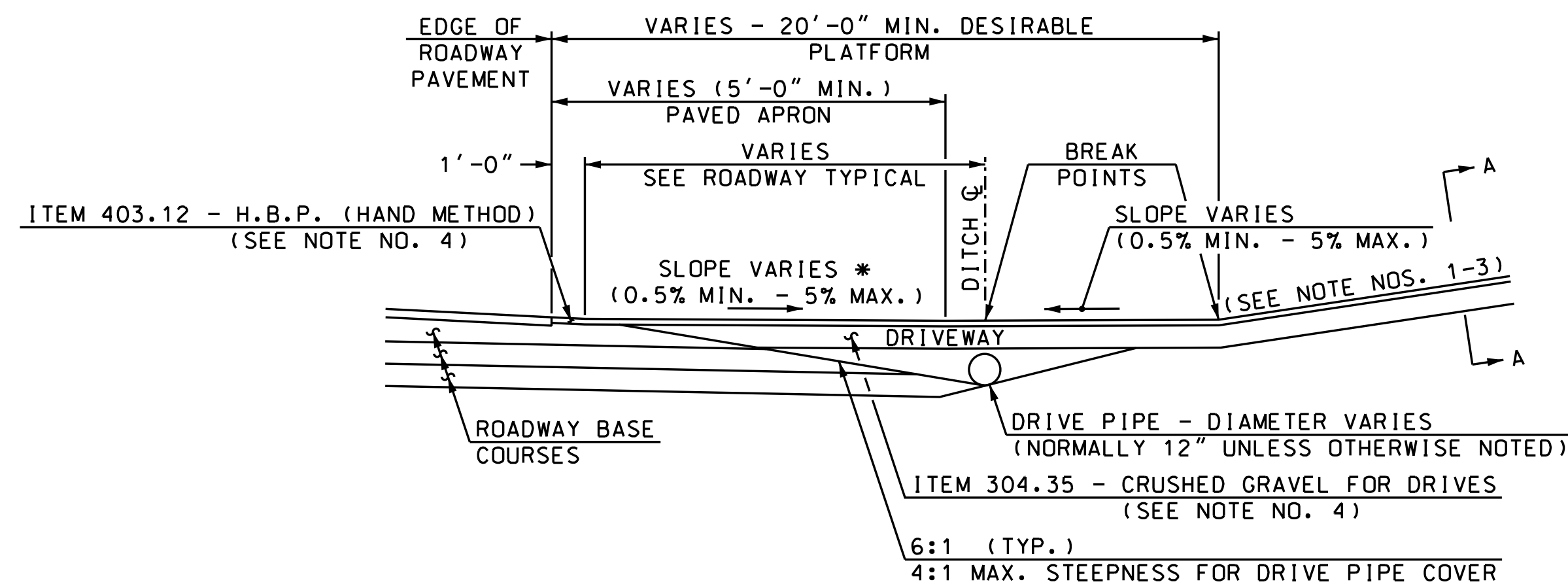

A-A DRIVEWAY CROSS-SECTION

TYPICAL UNCURBED DRIVE IN CUT SECTION

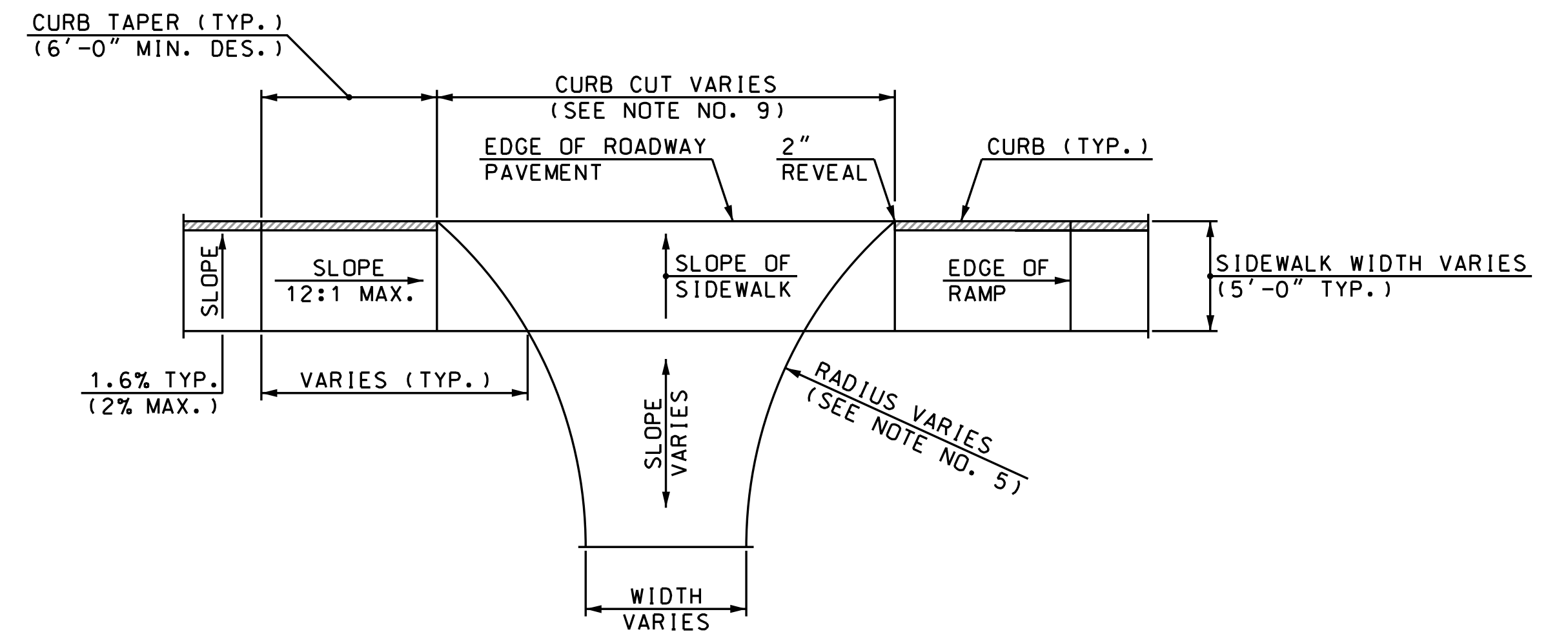

PLAN VIEW WITH SIDEWALK RAMP

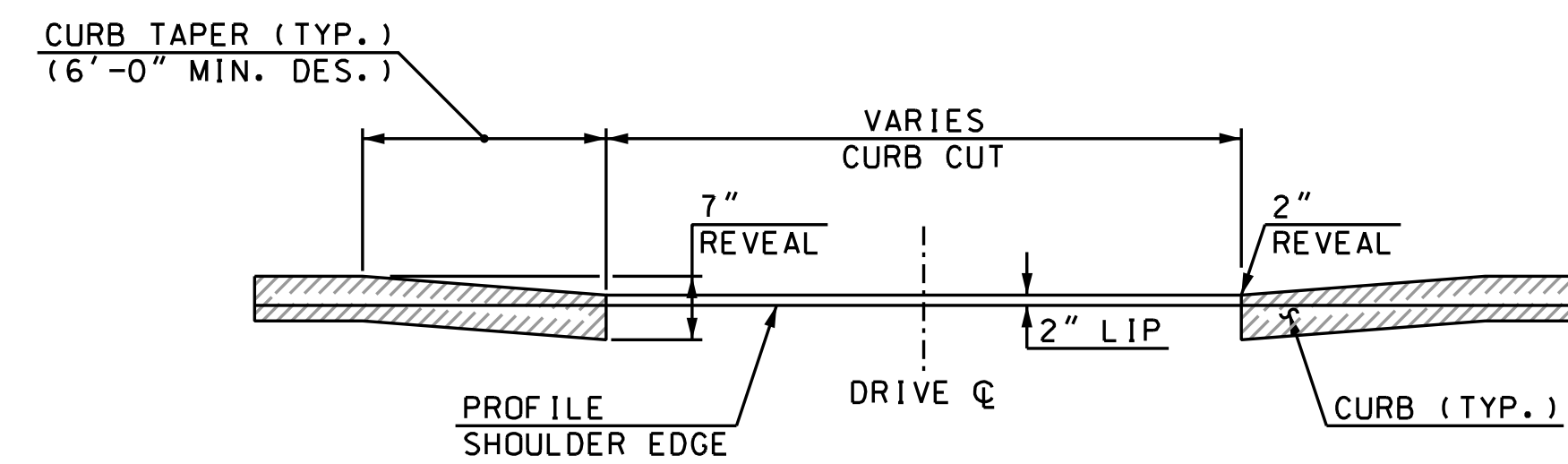

END VIEW

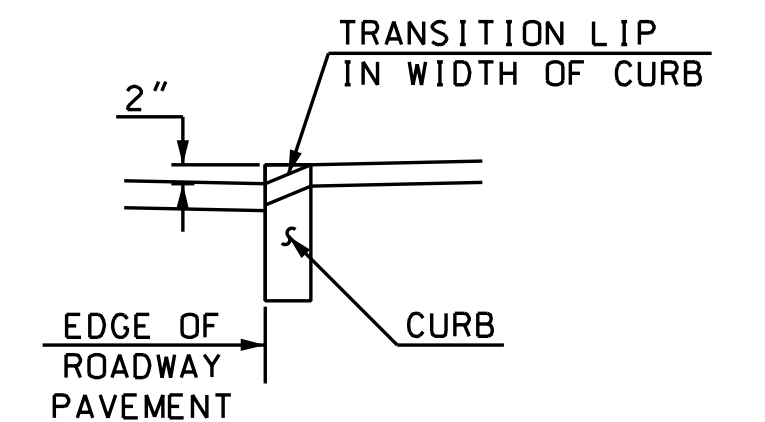

LIP DETAIL

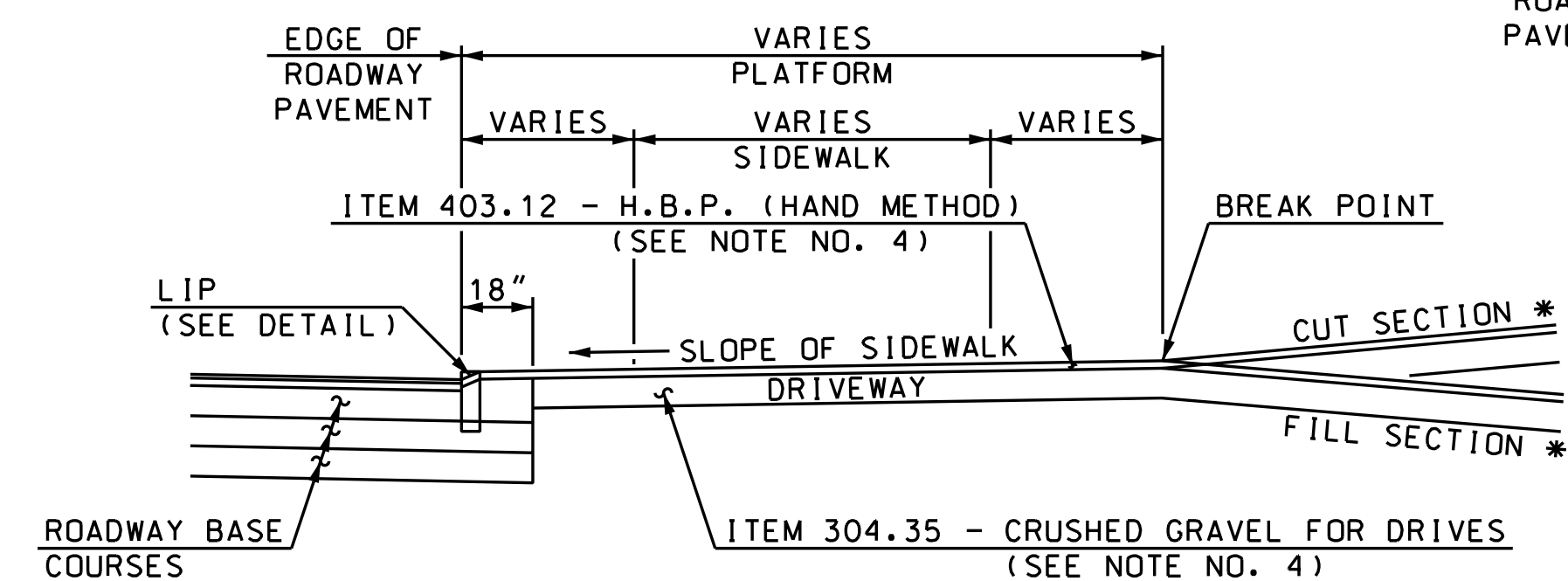

TYPICAL URBAN CURBED DRIVE IN CUT/FILL SECTION

GENERAL NOTES

1. GRADES OF MAJOR ENTRANCES BEYOND THE PLATFORM SHOULD NOT EXCEED 8%.
2. GRADES OF OTHER DRIVES BEYOND THE PLATFORM SHOULD NOT EXCEED 15%.
3. THE ALGEBRAIC DIFFERENCE BETWEEN TWO ADJACENT GRADES SHOULD NOT EXCEED 10%.
4. PAVEMENT AND BASE COURSE DEPTHS ARE:
 - A. TYPICALLY 8" CRUSHED GRAVEL WITH 3" HBP (HAND METHOD, PLACED IN 2 COURSES) FOR RESIDENTIAL DRIVES ADJACENT TO ROADWAYS WITH CONVENTIONAL CRUSHED GRAVEL, GRAVEL, AND SAND STRUCTURAL BOX. IF THE DRIVE IS ADJACENT TO A ROADWAY WITH A CRUSHED STONE STRUCTURAL BOX, 6" OF CRUSHED STONE FINE GRADATION MAY BE SUBSTITUTED FOR THE 8" OF CRUSHED GRAVEL NOTED ABOVE.
 - B. TYPICALLY 12" CRUSHED GRAVEL WITH 3" HBP (HAND METHOD, PLACED IN 2 COURSES) FOR COMMERCIAL DRIVES WITH FREQUENT HEAVY TRUCK TRAFFIC THAT ARE ADJACENT TO ROADWAYS WITH CONVENTIONAL CRUSHED GRAVEL, GRAVEL, AND SAND STRUCTURAL BOX. IF THE DRIVE IS ADJACENT TO A ROADWAY WITH A CRUSHED STONE STRUCTURAL BOX, 9" OF CRUSHED STONE FINE GRADATION MAY BE SUBSTITUTED FOR THE 12" OF CRUSHED GRAVEL NOTED ABOVE.
5. FOR DESIGN CRITERIA AND OTHER ADDITIONAL INFORMATION, REFER TO THE NHDOT DRIVEWAY MANUAL.
6. DITCHES ARE RECOMMENDED FOR UNCURBED DRIVEWAYS IN CUT SLOPES.
7. USE SLOPED END SECTIONS ON DRIVE PIPES FOR UNCURBED DRIVEWAYS.
8. CURBING CAN BE FLARED TO FIT DRIVE RADII IF APPROPRIATE OR ENDED AS DETAILED ABOVE.
9. CURB CUTS FOR RESIDENTIAL DRIVES WITH ANGLES OF ENTRY OF 75°-90° ARE TYPICALLY 25'-0".

| | | | | |
|---|----------|-------------------|-----------|--------------|
| STATE OF NEW HAMPSHIRE SPECIAL DETAILS | | | | |
| DEPARTMENT OF TRANSPORTATION • BUREAU OF HIGHWAY DESIGN | | | | |
| DRIVEWAY DETAILS | | | | |
| REVISION DATE | DGN | STATE PROJECT NO. | SHEET NO. | TOTAL SHEETS |
| 06/04/12 | driveway | - | 12 | 12 |