

## GENERAL NOTES

- ITEM 529.6, PRECAST CONCRETE SOUND ABATEMENT WALL (F) SHALL INCLUDE, ALL PRECAST CONCRETE SOUNDWALL PANELS, POSTS, LEVELING PANELS, STEEL BASE PLATES, CLOSED CELL EXPANSION MATERIAL, AND ALL HARDWARE AND INCIDENTAL MATERIALS NECESSARY FOR CONSTRUCTION OF THE SOUNDWALL AS DETAILED ON THE PLANS.
- SEE SECTION 529 SPECIAL PROVISION FOR ADDITIONAL INFORMATION AND REQUIREMENTS.
- THE ANGLE BETWEEN THE PRECAST CONCRETE POST AND WALL PANEL SHALL NOT EXCEED 10 DEGREES. POSTS SHALL BE HORIZONTALLY ALIGNED TO ACHIEVE THE PROPOSED WALL ALIGNMENT WITH ANGLE POINTS NOT TO EXCEED 20 DEGREES.
- TRANSITIONS IN TOP OF WALL ELEVATION SHALL BE AS DETAILED ON THE PLANS.
  - WHERE THE TOP OF WALL ELEVATION IS THE SAME ON BOTH SIDES OF A POST, THE MAXIMUM ALLOWABLE DISTANCE FROM THE TOP OF WALL TO TOP OF POST SHALL BE 6".
  - WHERE THE TOP OF WALL ELEVATION VARIES ON BOTH SIDES OF A POST THE MAXIMUM ALLOWABLE DISTANCE FROM THE TOP OF WALL TO TOP OF POST SHALL BE 12".
- ALL PANELS SHALL BE 4'-0" TALL, EXCEPT FOR THE UPPER TWO PANELS BETWEEN EACH POST, WHICH SHALL VARY IN HEIGHT TO ACHIEVE THE DESIRED TOP OF WALL ELEVATION.
- THE MAXIMUM POST SPACING SHALL BE 18'-0" OR 20'-0" BASED ON EXPOSURE HEIGHT OF WALL (SEE DETAIL AND TABLE THIS SHEET). ALL POSTS SHALL BE SPACED AT THE MAXIMUM POST SPACING UNLESS A REDUCED POST SPACING IS REQUIRED TO AVOID UNDERGROUND OR OTHER CONFLICTS.
- FOR LAYOUT OF SOUNDWALL (INCLUDING POST/SHAFT NUMBERS, WORKING POINT COORDINATES, AND WALL ELEVATIONS), SEE PLAN SHEETS INCLUDED ELSEWHERE IN THIS CONTRACT.
- VERTICAL REINFORCING STEEL FOR THE POSTS SHALL HAVE THE **BOTTOM 5"** THREADED. ANCHOR RODS SHALL HAVE THE **TOP 8"** THREADED. THREADING SHALL BE TO THE SIZE SPECIFIED ON THE PLANS AND IN ACCORDANCE WITH SECTION 550.
- COAT ALL PRECAST SURFACES (SOUNDWALL PANELS, POSTS, AND LEVELING PANELS) WITH WATER REPELLENT (SILANE-SILOXANE) IN ACCORDANCE WITH SECTION 534. ALL COSTS SUBSIDIARY TO ITEM 529.6.
- CLEAR COVER FOR REINFORCEMENT SHALL BE AS SHOWN ON THE PLANS.
- ALL EXPOSED CONCRETE EDGES SHALL BE CHAMFERED  $\frac{3}{4}$ " UNLESS OTHERWISE NOTED.
- PRECAST CONCRETE SOUNDWALL PANELS SHALL HAVE A SC - ASHLAR ARCHITECTURAL FINISH ON BOTH FACES, CAST USING PATTERN NO. 1515 FORM LINERS BY SPEC FORMLINERS, INC. PRECAST CONCRETE LEVELING PANELS SHALL BE CAST SMOOTH. SEE SECTION 529 SPECIAL PROVISION FOR MORE INFORMATION.
- LIFTING POINTS AND DEVICES SHALL BE DESIGNED BY THE CONTRACTOR AND SUBMITTED FOR APPROVAL. ALL UPWARD FACING RECESSES FOR LIFTING DEVICES SHALL BE FILLED WITH AN APPROVED NON-SHRINK GROUT AFTER OR DURING ERECTION.

## DESIGN CRITERIA

- SPECIFICATIONS: AASHTO LRFD BRIDGE DESIGN SPECIFICATIONS, 9TH ED., 2020, SECTION 15 NHDOT 2016 STANDARD SPECIFICATIONS AS AMENDED. SPECIAL PROVISION SECTION 529 - PRECAST CONCRETE SOUND ABATEMENT WALL
- DESIGN LOADING: WIND PRESSURE (STRENGTH III):
  - 42 PSF (EXPOSURE HEIGHT = 40')
  - 46 PSF (EXPOSURE HEIGHT = 60')
 WHERE:
  - $V = 123$  MPH (AASHTO FIG. 3.8.1.1.2-1)
  - $K_z(c)$  GROUND SURFACE ROUGHNESS CATEGORY C, OPEN TERRAIN
    - = 1.05 (EXPOSURE HEIGHT = 40')
    - = 1.14 (EXPOSURE HEIGHT = 60')
  - $G = 0.85$
  - $C_D = 1.2$
- DESIGN DIMENSIONS: MAXIMUM WALL HEIGHT = 25'-0"  
MAXIMUM POST SPACING = 18'-0" OR 20'-0" (SEE GENERAL NOTE 6)
- MATERIALS:
  - CONCRETE FOR THE SOUNDWALL PANELS, POSTS, AND LEVELING PANELS SHALL HAVE A MINIMUM 28 DAY COMPRESSIVE STRENGTH OF 4,000 PSI AND SHALL CONFORM TO SECTION 520 FOR CLASS AA CONCRETE UNLESS NOTED OTHERWISE. ALL PRECAST CONCRETE SHALL HAVE CORROSION INHIBITOR (CALCIUM NITRATE) ADMIXTURE ADDED AT A RATE OF 3 GALLONS PER CUBIC YARD.
  - ALL REINFORCING STEEL SHALL CONFORM TO AASHTO M 31, (ASTM A615) GRADE 60. ALL WELDED WIRE FABRIC SHALL CONFORM TO AASHTO M55.
  - VERTICAL REINFORCING STEEL FOR THE POSTS SHALL BE GALVANIZED AFTER FABRICATION IN ACCORDANCE WITH SECTION 529 SPECIAL PROVISION. TIE BARS IN POSTS SHALL BE GALVANIZED OR EPOXY COATED IN ACCORDANCE WITH SECTION 544. REINFORCING BARS AND WELDED WIRE FABRIC IN THE SOUNDWALL PANELS AND LEVELING PANELS SHALL BE BLACK (UNCOATED) STEEL.
  - STRUCTURAL STEEL FOR BASE PLATES SHALL CONFORM TO ASTM A572, GRADE 50 AND BE GALVANIZED AFTER FABRICATION IN ACCORDANCE WITH SPECIAL PROVISION SECTION 529.
  - ANCHOR RODS SHALL CONFORM TO AASHTO M 31 (ASTM A615), GRADE 60 AND SHALL BE FABRICATED IN ACCORDANCE WITH SECTION 550. ANCHOR RODS SHALL BE GALVANIZED IN ACCORDANCE WITH SPECIAL PROVISION SECTION 529.
  - NUTS SHALL CONFORM TO ASTM A563, GRADE DH AND WASHERS SHALL BE HARDENED AND CONFORM TO ASTM F436, TYPE 1. ALL HARDWARE SHALL BE GALVANIZED IN ACCORDANCE WITH SPECIAL PROVISION SECTION 529.

## PRECAST CONCRETE TOLERANCES

- POST DIMENSIONAL TOLERANCES:
  - TOTAL HEIGHT =  $\pm \frac{1}{2}$ "
  - FLANGE WIDTH =  $\pm \frac{1}{4}$ "
  - WEB THICKNESS =  $\pm \frac{1}{4}$ "
  - SLOT DEPTH AND LOCATION =  $\pm \frac{3}{8}$ "
  - VERTICAL SWEEP POSTS  $\leq 15.0'$  =  $\pm \frac{1}{8}$ "
  - VERTICAL SWEEP POSTS 15.1' TO 25.0' =  $\pm \frac{1}{4}$ "
- PANEL DIMENSIONAL TOLERANCES:
  - LENGTH AND HEIGHT =  $\pm \frac{1}{4}$ "
  - STRUCTURAL THICKNESS =  $\pm \frac{1}{4}$ ", -0"
  - HORIZONTAL SWEEP =  $\pm \frac{1}{2}$ "
  - VERTICAL CAMBER =  $\pm \frac{3}{8}$ ", -0"
  - OUT OF SQUARE =  $\frac{1}{8}$ " PER 10', WITH  $\frac{3}{8}$ " MAX.

## DRILLED SHAFT NOTES

- ITEM 509.2, DRILLED SHAFT SHALL INCLUDE CONCRETE, REINFORCING, ANCHOR RODS, WATER REPELLENT AND ALL HARDWARE AND INCIDENTAL MATERIAL NECESSARY FOR THE CONSTRUCTION OF THE DRILLED SHAFTS AS SHOWN ON THE PLANS AND SPECIAL PROVISIONS.
- DRILLED SHAFT CONSTRUCTION METHODS, CONCRETE, AND REINFORCING REQUIREMENTS SHALL BE IN ACCORDANCE WITH THE SECTION 509 SPECIAL PROVISION.
- WHERE FILL EMBANKMENT IS TO BE CONSTRUCTED ABOVE THE EXISTING GROUND, THE EMBANKMENT SHALL BE BUILT PRIOR TO CONSTRUCTING THE SHAFTS. PLACEMENT AND COMPACTION OF THE FILL SHALL BE IN ACCORDANCE WITH SECTION 203.
- SEE PRECAST CONCRETE SOUNDWALL SHEET (4 OF 4) IF BEDROCK IS ENCOUNTERED.
- CONCRETE FOR THE DRILLED SHAFTS SHALL HAVE A MINIMUM 28 DAY COMPRESSIVE STRENGTH OF 3,000 PSI CLASS A CONCRETE AND SHALL CONFORM TO SECTION 520 UNLESS NOTED OTHERWISE.
- ALL REINFORCING STEEL SHALL CONFORM TO AASHTO M 31, GRADE 60. ALL REINFORCING STEEL SHALL BE A MINIMUM OF 3" CLEAR FROM CONCRETE SURFACES UNLESS NOTED OTHERWISE.
- COAT CONCRETE SURFACES OF THE DRILLED SHAFTS TO 1'-0" BELOW FINISHED GRADE WITH WATER REPELLENT (SILANE-SILOXANE) IN ACCORDANCE WITH SECTION 534. ALL COSTS SUBSIDIARY TO ITEM 509.2, DRILLED SHAFT.

## NOTES TO DESIGNER:

- THE SOUND ABATEMENT WALL AND DRILLED SHAFTS DETAILED ON THESE PLANS HAVE BEEN DESIGNED IN ACCORDANCE WITH THE DESIGN CRITERIA NOTED ON THIS SHEET. IT IS THE DESIGNER'S RESPONSIBILITY TO DETERMINE THE SUITABILITY OF THESE DETAILS FOR EACH PROJECT BASED ON PROJECT SPECIFIC INFORMATION. IF A REDESIGN IS REQUIRED, NEW DETAILS SHALL BE DEVELOPED AND STAMPED BY A PROFESSIONAL ENGINEER LICENSED IN THE STATE OF NEW HAMPSHIRE. THE TITLE BLOCK SHALL BE UPDATED WITH DESIGNER'S INITIALS.
- THE SOUND ABATEMENT WALL FOUNDATION SHALL BE DESIGNED (DRILLED SHAFT AND ROCK SOCKET LENGTHS) FOR EACH PROJECT BASED ON PROJECT SPECIFIC INFORMATION. THE DESIGNER SHALL WORK CLOSELY WITH THE GEOTECHNICAL ENGINEER FOR THE DESIGN OF THE DRILLED SHAFT FOUNDATIONS.
- THE DESIGNER SHALL COMPLETE PLAN SHEETS THAT INCLUDE A SOUNDWALL LOCATION CHART AND WALL LAYOUT DETAILS SUCH AS ELEVATION, SECTION, AND PLAN VIEWS. THE DESIGNER SHALL DETERMINE THE LOWER SURROUNDING GROUND ELEVATION AND LAYOUT POST LOCATIONS BASED ON THE MAXIMUM POST SPACING SHOWN IN THE TABLE BELOW.
- THE TOP OF WALL ELEVATIONS NOTED IN THE SOUNDWALL NOISE STUDY MAY REQUIRE ADJUSTMENT TO MAINTAIN THE 12" MAX. ELEVATION CHANGE FROM THE POST TO THE NEXT PANEL AS SHOWN ON SHEET 2 OF 4.
- WHEN WALL HEIGHT IS DIFFERENT BETWEEN ADJACENT SEGMENTS, USE HIGHER VALUE FOR SELECTION OF POSTS, BASE PLATES, FOUNDATIONS, ANCHOR BOLTS, AND POST SPACING.
- IF A REDUCED POST SPACING IS USED, THE DESIGNER SHALL CLEARLY NOTE THE REDUCED SPACING ON THE SOUNDWALL LAYOUT SHEETS SO THE FABRICATOR CAN ADJUST THE PANEL LENGTHS AS NEEDED.

## TO BE COMPLETED BY DESIGNER:

### SUMMARY OF SOUNDWALL QUANTITIES

ITEM NO.	ITEM DESCRIPTION	SOUNDWALL LOCATION & QUANTITY			UNIT
		WALL 1	WALL 2	WALL 3	
509.1	MOBILIZATION AND DEMOBILIZATION OF DRILLED SHAFT DRILLING EQUIPMENT				UNIT
509.2	DRILLED SHAFT				LF
509.3	OBSTRUCTION REMOVAL				LF
509.4	ROCK SOCKET EXCAVATION				LF
529.6	PRECAST CONCRETE SOUND ABATEMENT WALL (F)				SF

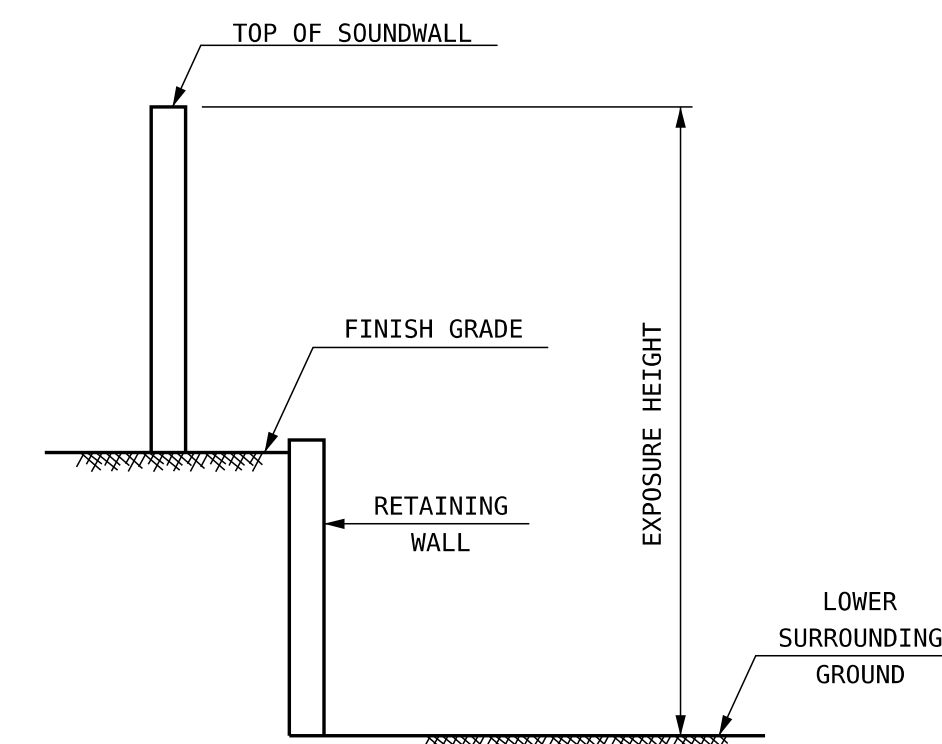

SECTION - RETAINING WALL

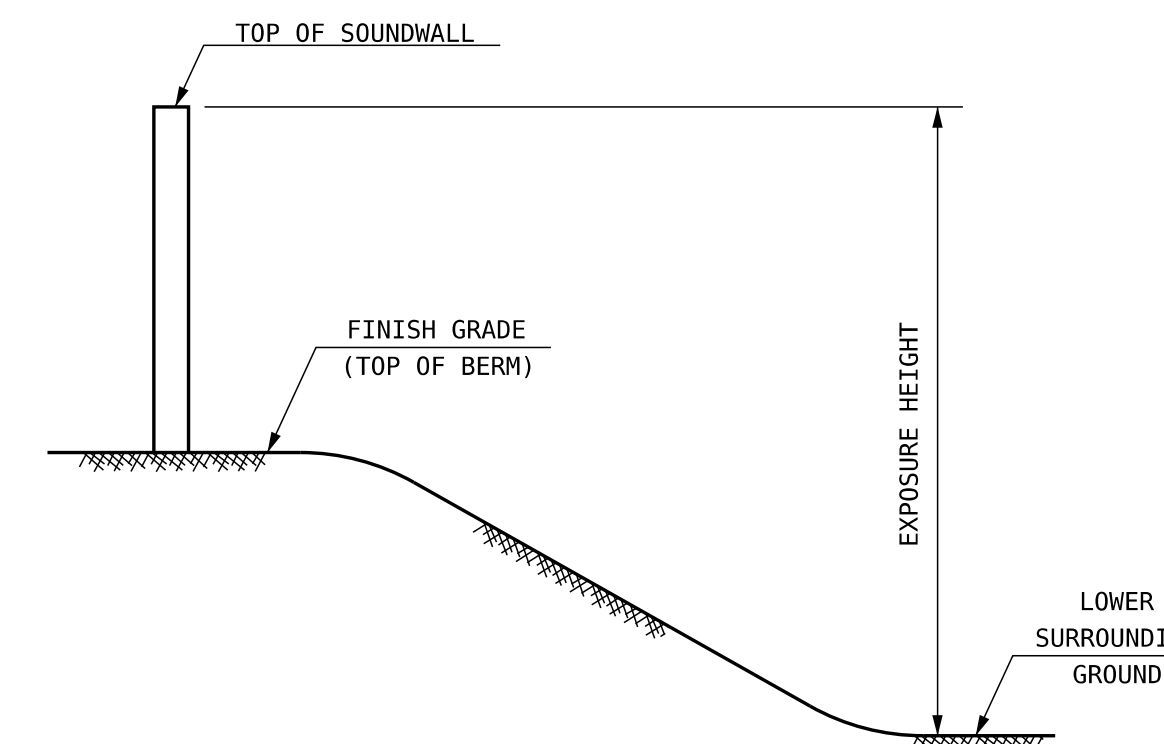

SECTION - BERM

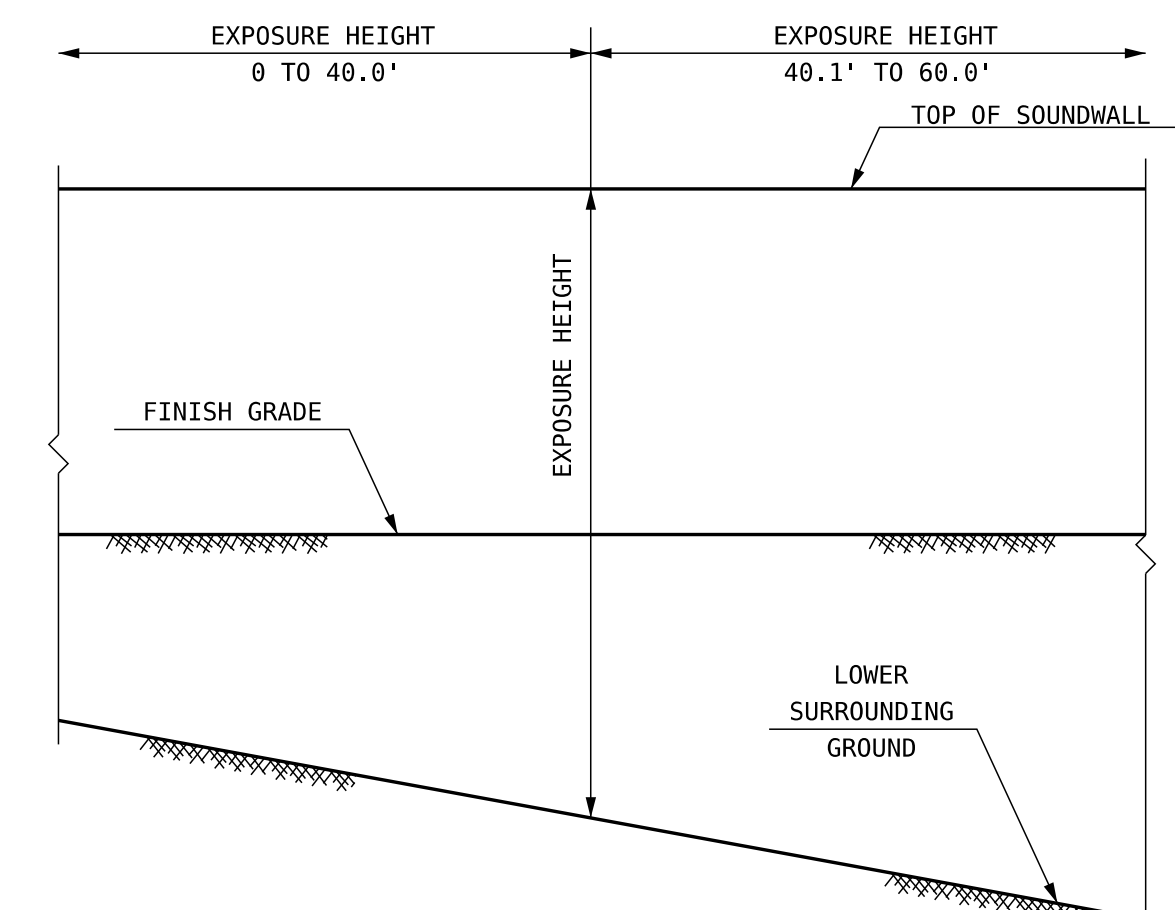

ELEVATION

### MAXIMUM POST SPACING AND EXPOSURE HEIGHT DETAIL

MAXIMUM POST SPACING TABLE (SEE GENERAL NOTE 6)	
EXPOSURE HEIGHT	MAX. POST SPACING
0 TO 40.0'	20'-0"
40.1' TO 60.0'	18'-0"

NO MODIFICATIONS SHALL BE MADE TO THIS SHEET, EXCEPT AS NOTED IN CLOUDS. IF ANY MODIFICATIONS ARE MADE TO THIS SHEET, THAT PERSON SHALL BECOME THE DESIGNER AND ENGINEER OF RECORD.

SUBDIRECTORY	.DGN LOCATOR	SHEET SCALE
SOUNDWALL/CONCRETE	Soundwall (1 of 4)	AS NOTED

STATE OF NEW HAMPSHIRE DEPARTMENT OF TRANSPORTATION * BUREAU OF BRIDGE DESIGN					
TOWN	BRIDGE NO.		STATE PROJECT		
LOCATION					
<b>PRECAST CONCRETE SOUNDWALL (1 OF 4)</b>					BRIDGE SHEET
REVISIONS AFTER PROPOSAL	BY	DATE	BY	DATE	XX OF
	DESIGNED	VHB 11/22	CHECKED	JGM 11/22	FILE NUMBER
	DRAWN	BJM 11/22	CHECKED	JGM/LRL 11/22	
	QUANTITIES	XXX	CHECKED	XXX	XX/XX
	ISSUE DATE	12/21/21	FEDERAL PROJECT NO.		SHEET NO.
	REV. DATE	7/31/23			TOTAL SHEETS

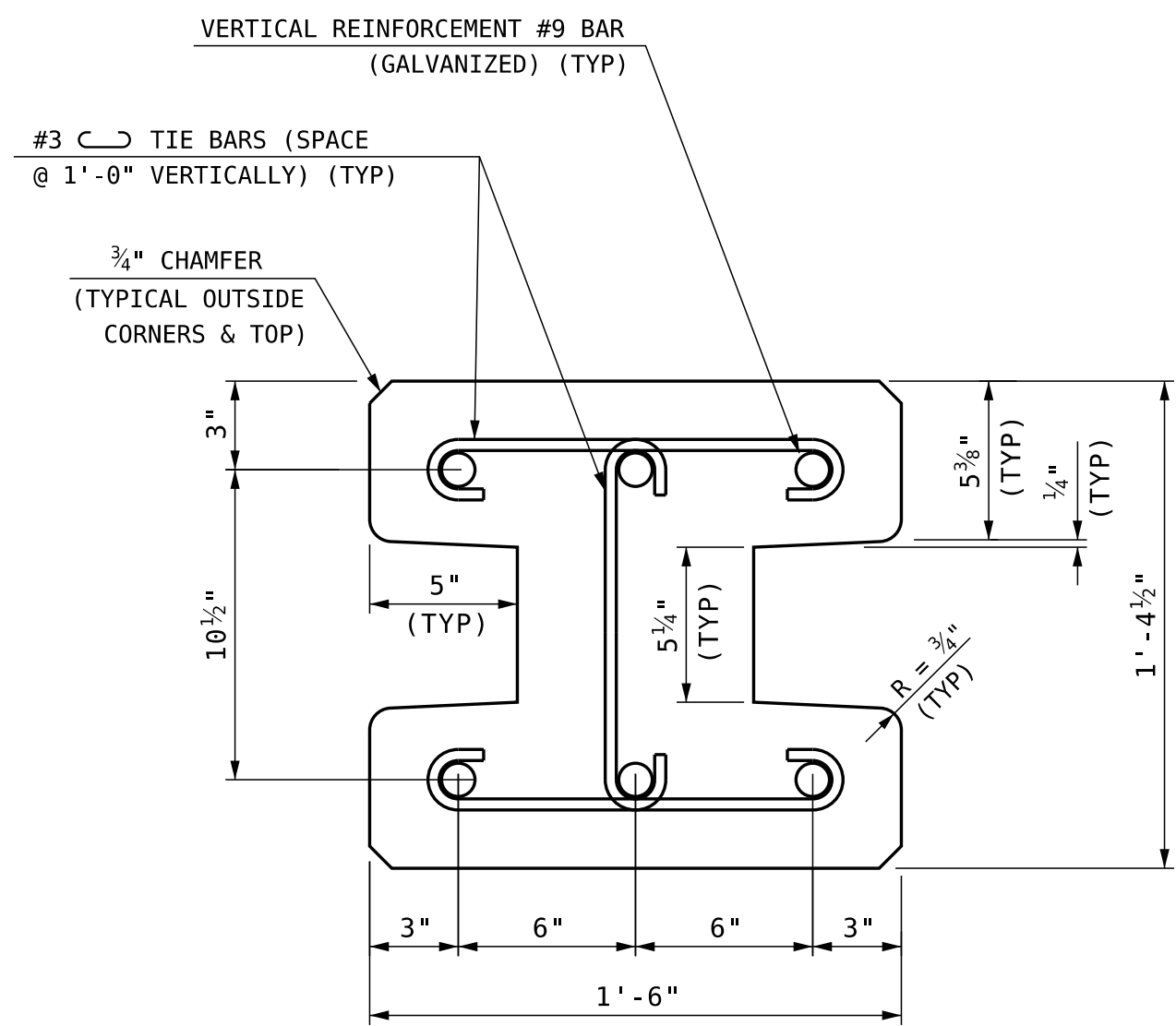

**POST SECTION DETAIL**  
FOR POST LENGTHS  $\leq 15.0'$

SCALE: 2" = 1'-0"

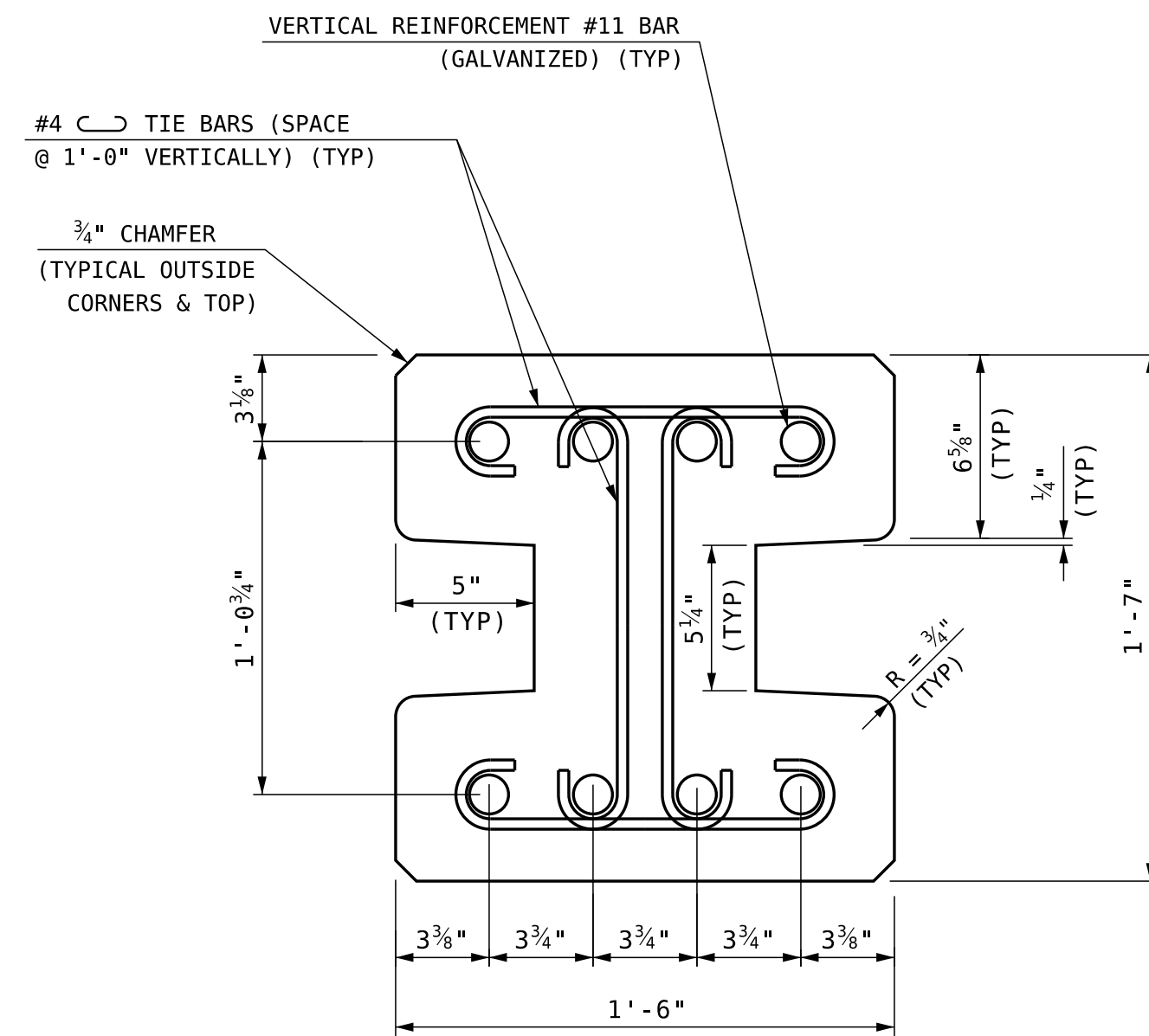

**POST SECTION DETAIL**  
FOR POST LENGTHS 15.1' TO 25.0'

SCALE: 2" = 1'-0"

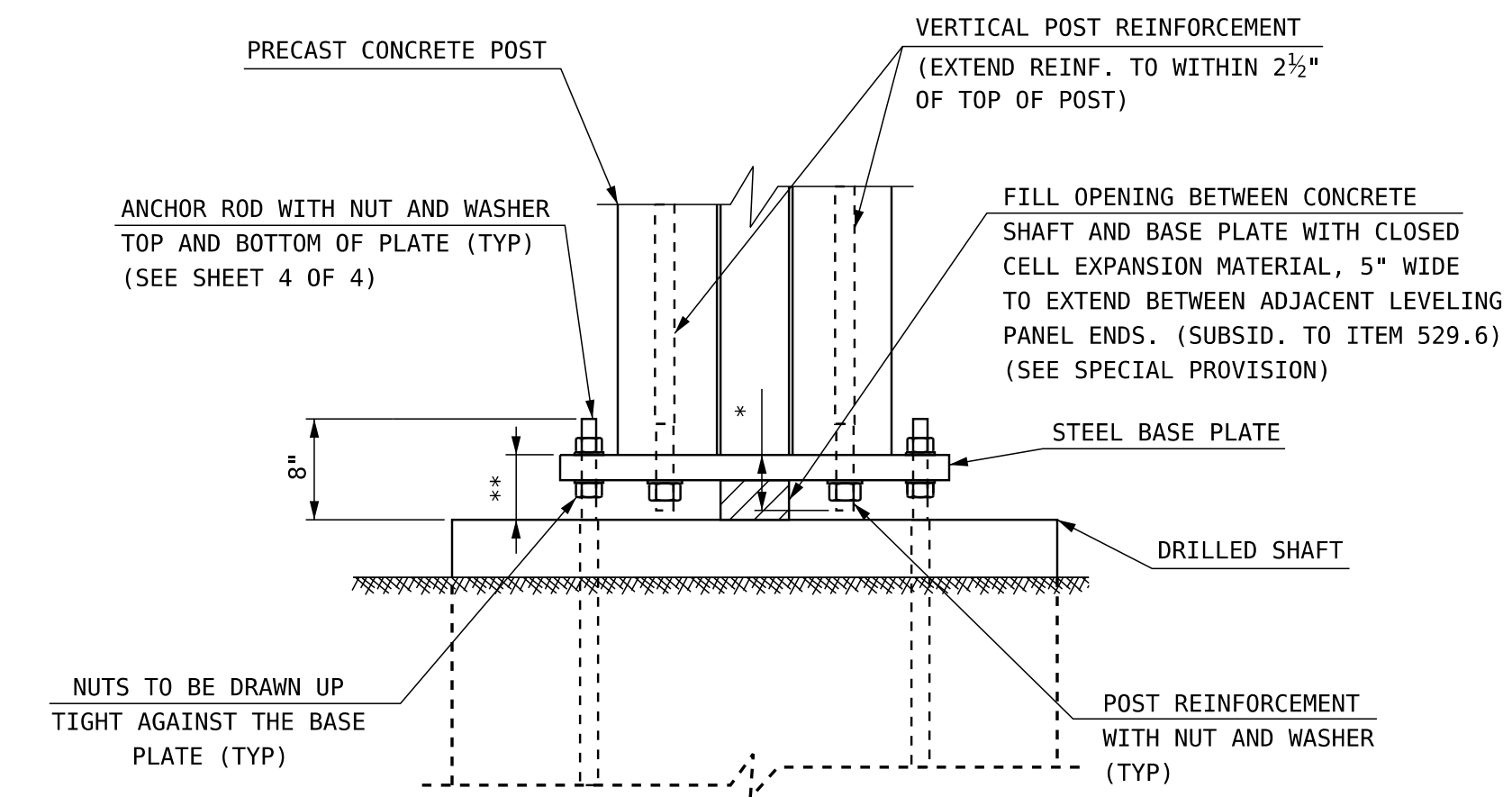

\* THREADS OF THE VERTICAL POST REINFORCEMENT SHALL EXTEND BEYOND THE BOTTOM OF THE POST:  
 $3\frac{1}{2}''$  FOR POSTS  $\leq 15.0'$   
 $4\frac{1}{2}''$  FOR POSTS 15.1' TO 25.0'  
 THE **BOTTOM 5"** OF THE VERTICAL POST REINFORCEMENT SHALL BE THREADED FOR **ALL** POSTS.

\*\* DISTANCE BETWEEN TOP OF DRILLED SHAFT AND TOP OF BASE PLATE:  
 $4''$  FOR POSTS  $\leq 15.0'$   
 $5''$  FOR POSTS 15.1' TO 25.0'

CUT THREAD SIZES SHALL BE :  $1''$  - 8 UNC FOR #9 BARS  
 $1\frac{1}{4}''$  - 8 UN FOR #11 BAR

**POST CONNECTION DETAIL**  
SCALE: 1"=1'-0"

+

...

×

**NHDOT Bridge Design**  
7/31/2023

Revisions made to Bridge Detail Sheet are highlighted.  
Go to website for current Detail Sheet.

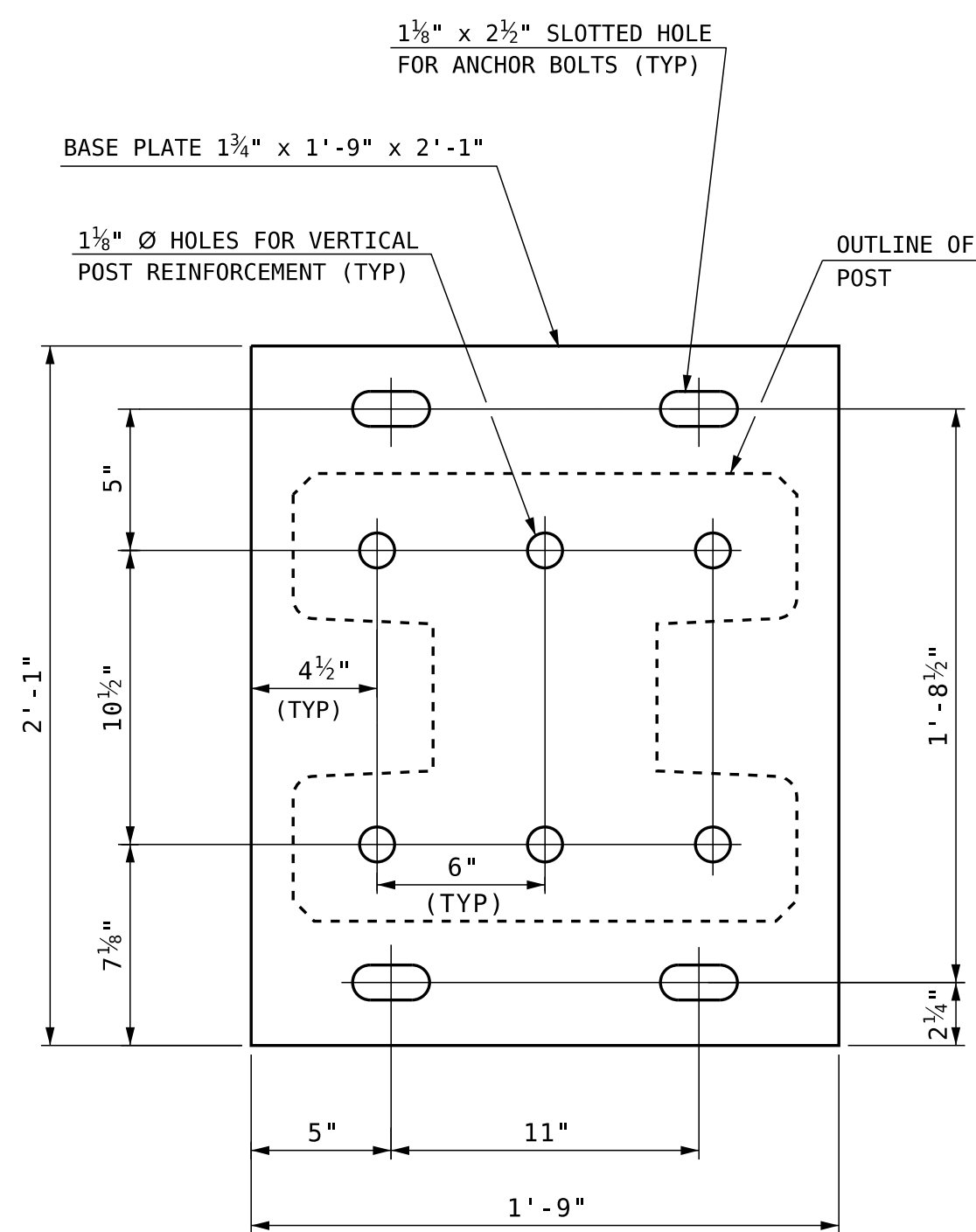

**POST BASE PLATE DETAIL**  
FOR POST LENGTHS  $\leq 15.0'$

SCALE: 2" = 1'-0"

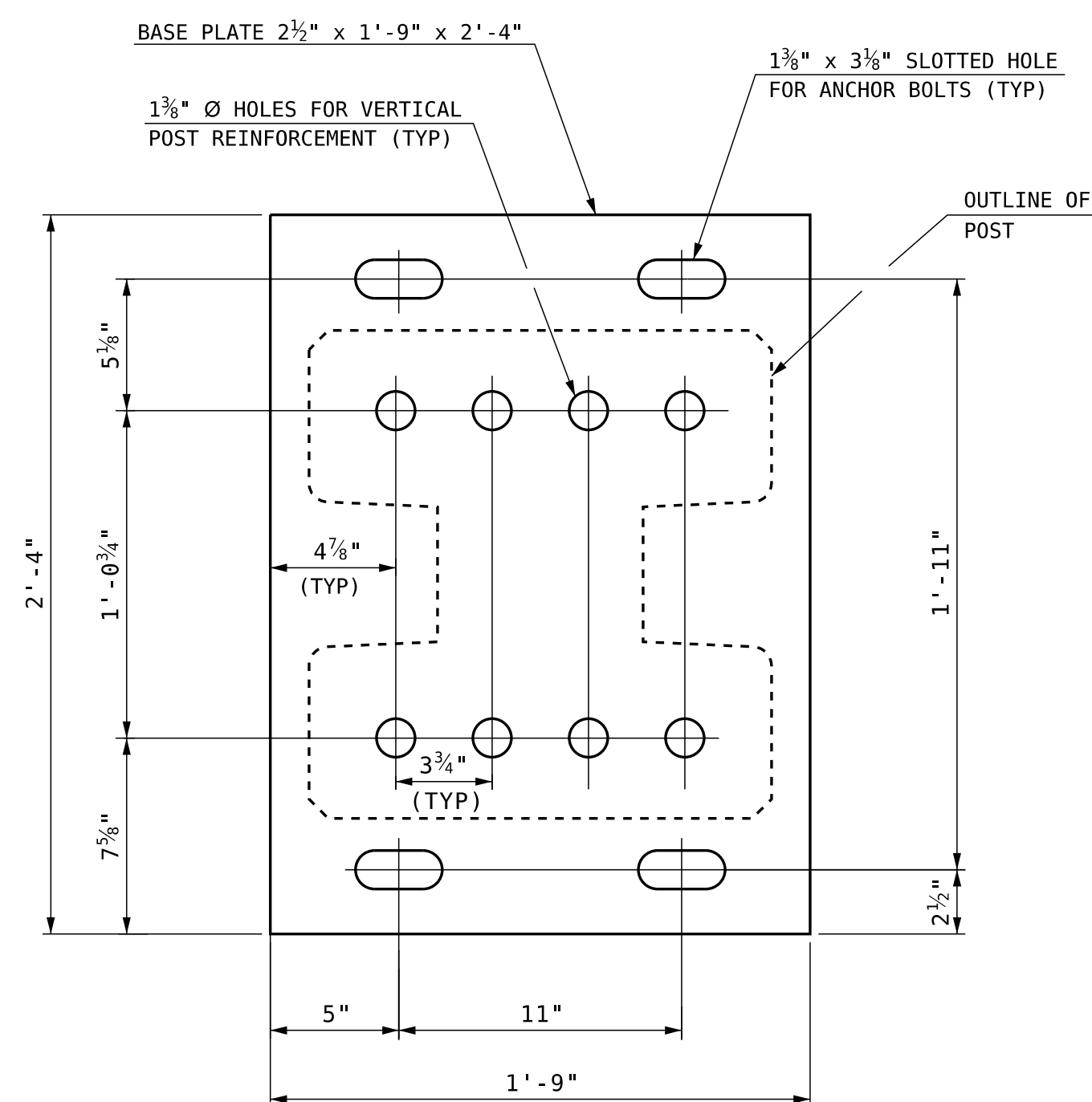

**POST BASE PLATE DETAIL**  
FOR POST LENGTHS 15.1' TO 25.0'

SCALE: 2" = 1'-0"

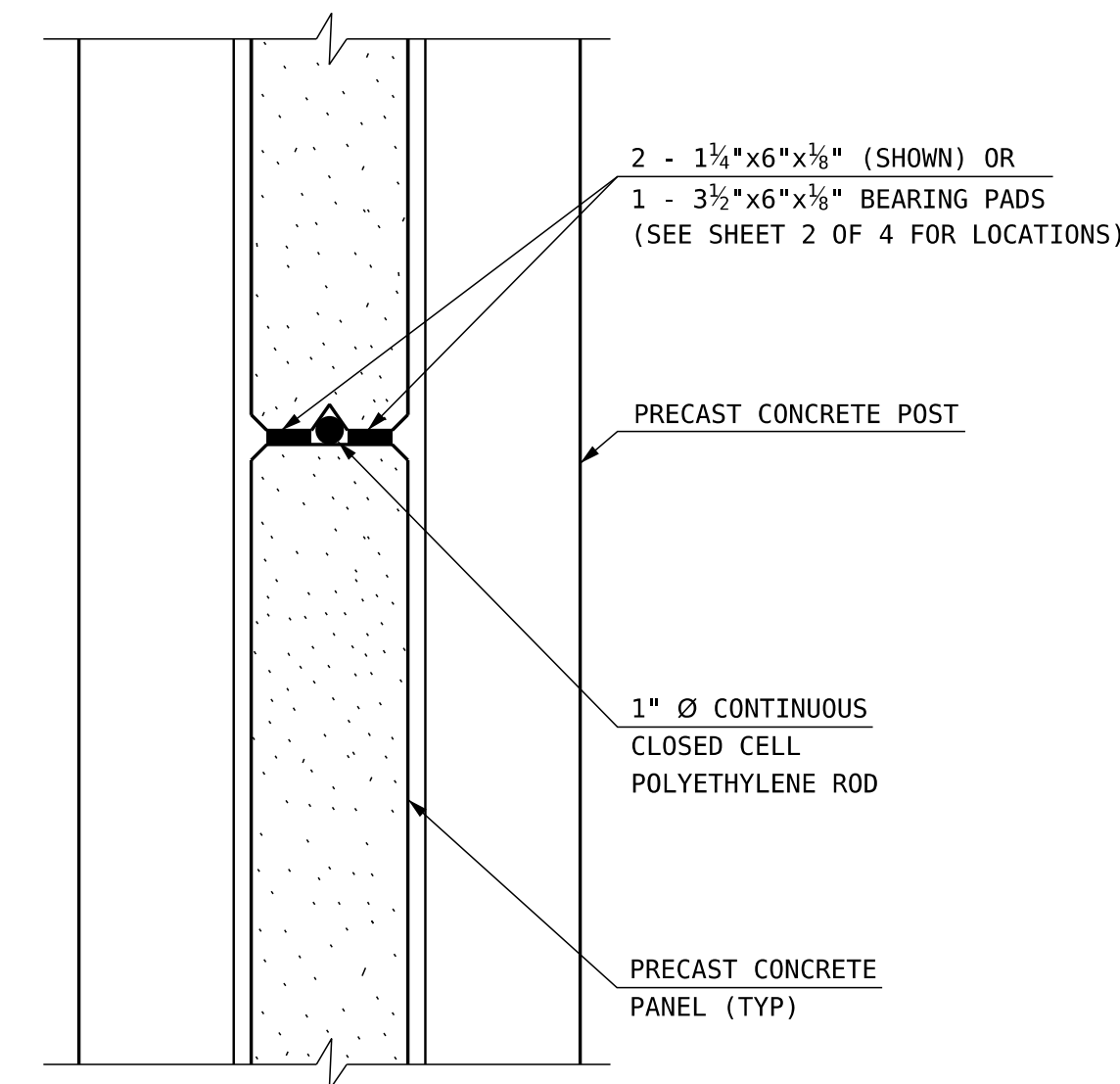

**PANEL JOINT DETAIL**  
(SC - ASHLAR ARCHITECTURAL FINISH NOT SHOWN)  
SCALE: 2" = 1'-0"

**NOTES:**

- SEE PRECAST CONCRETE SOUNDWALL (1 OF 4) SHEET FOR NOTES AND DESIGN CRITERIA.
- POLYETHYLENE ROD AND BEARING PADS SHALL BE ATTACHED TO BOTTOM OF PANEL USING SPRAY ADHESIVE OR SIMILAR DURING ERECTION.

NO MODIFICATIONS SHALL BE MADE TO THIS SHEET. IF ANY MODIFICATIONS ARE MADE TO THIS SHEET, THAT PERSON SHALL BECOME THE DESIGNER AND ENGINEER OF RECORD.

STATE OF NEW HAMPSHIRE										
DEPARTMENT OF TRANSPORTATION * BUREAU OF BRIDGE DESIGN										
TOWN		BRIDGE NO.			STATE PROJECT					
LOCATION										
PRECAST SOUNDWALL (3 OF 4)									BRIDGE SHEET	
REVISIONS AFTER PROPOSAL		BY	DATE	CHECKED	BY	DATE	XX OF			
		DESIGNED	VHB	11/22	CHECKED	JGM	11/22	FILE NUMBER		
		DRAWN	BJM	11/22	CHECKED	JGM/LRL	11/22			
		QUANTITIES	XXX	XX/XX	CHECKED	XXX	XX/XX			
SUBDIRECTORY		.DGN LOCATOR		SHEET SCALE		ISSUE DATE		TOTAL SHEETS		
SOUNDWALL/CONCRETE		Soundwall (3 of 4)		AS NOTED		12/21/23		7/31/23		