



August 2018

NHDOT in collaboration with the Town of Hampton
and the Hampton Beach Area Commission

HAMPTON, X-A002(776), #23821

Hampton Beach Area Master Plan - Transportation Update



Table of Contents

1 Introduction	1
2 Existing Conditions	3
Introduction	3
Study Area	3
Route 1A (Ocean Boulevard) and State Park Drive	4
Route 1A (Ocean Boulevard/Ashworth Avenue), Duston Avenue, and Dover Avenue	4
Route 1A (Ocean Boulevard) and Highland Avenue	4
Route 1A (Ocean Boulevard) and Church Street	5
Route 1A (Ocean Boulevard) and Route 101E (Winnacunnet Road).....	5
Route 1A (Ocean Boulevard) and Route 27 (High Street).....	6
Traffic Volumes.....	6
Truck Volumes.....	8
Peak Hour Volumes.....	8
Travel Speeds	9
Parking	10
Operating Conditions	11
Level of Service Criteria.....	11
Transit	14
Scenic Byways	15
Pedestrian and Bicycle Accommodations.....	15
Safety Issues	17
Incidents	18
Emergency Vehicle Access	18
Special Events	18
Seafood Festival.....	19
Fourth of July.....	19
3 Recommendations	21
Ashworth Avenue	22
2018 Investigations and Recommendations.....	22
Additional Engineering Design Considerations.....	24
Route 1A from Hampton Harbor Bridge to Dover Avenue	24
2018 Investigations and Recommendations.....	24
Additional Engineering Design Considerations.....	26
Ocean Boulevard from Dover Avenue to Haverhill Avenue	27
2018 Investigations and Recommendations.....	27
Additional Engineering Design Considerations.....	27
Ocean Boulevard from Haverhill Avenue to Ashworth Avenue	28
2018 Investigations and Recommendations.....	28

Additional Engineering Design Considerations.....	29
Ocean Boulevard from Ashworth Avenue to Great Boars Head Avenue	29
2018 Investigations and Recommendations.....	29
Additional Engineering Design Considerations.....	30
Ocean Boulevard from Great Boars Head Avenue to Winnacunnet Road	31
2018 Investigations and Recommendations.....	31
Additional Engineering Design Considerations.....	34
4 Construction Cost Estimates and Roadway Segment Prioritization	35

List of Tables

Table No.	Description	Page
Table 1	ATR Counts.....	8
Table 2	LOS Criteria for Unsignalized Intersections.....	11
Table 3 -	Unsignalized Intersection Capacity Analysis Summary	13 and 14
Table 4	Construction Cost Estimates	36

List of Figures

Figure No.	Description
Figure 1A	2018 Transportation Update Study Area
Figure 1B	Expanded 2018 Transportation Update Study Area
Figure 2	Intersection at Ocean Boulevard and Winnacunnet Road
Figure 3	Average Daily Traffic Volumes Along Major Intersections on Ocean Boulevard
Figure 4A	2014 Saturday Midday (10:45AM) Peak Hour Traffic Volumes
Figure 4B	2014 Saturday Evening (5:30 PM) Peak Hour Traffic Volumes
Figure 4C	2014 Saturday Midday (10:45AM) Peak Hour Pedestrian Volumes
Figure 4D	2014 Saturday Evening (5:30 PM) Peak Hour Pedestrian Volumes
Figure 5	Speed Statistics Along Ocean Boulevard in Hampton
Figure 6A	Parking Inventory
Figure 6B	Parking Inventory Expanded Study Area
Figure 7A	Bicycle and Pedestrian Facilities
Figure 7B	Bicycle and Pedestrian Facilities Expanded Study Area
Figure 8	Recommended Alternative for Ashworth Avenue
Figure 9	Signalized Intersection Alternative - Route 1A and State Park Drive
Figure 10	Roundabout Alternative - Route 1A and State Park Drive
Figure 11	Recommended Two-Lane Northbound Alternative for Ocean Boulevard - Dover Avenue to Haverhill Avenue
Figure 12	Recommended Two-Lane Northbound Alternative for Ocean Boulevard - Haverhill Avenue to H Street
Figure 13	Recommended Two-Lane Alternative Northbound for Ocean Boulevard - H Street to B Street
Figure 14	Recommended Alternative for Ocean Boulevard - Great Boars Head Avenue Approaching Winnacunnet Road
Figure 15	Recommended Alternative for Ocean Boulevard at Winnacunnet Road

1

Introduction

In November 2014, the Town of Hampton and the Hampton Beach Area Commission (HBAC), in collaboration with the New Hampshire Department of Transportation (NHDOT), began the process to further evaluate and refine the transportation strategies outlined in the November 7, 2001 Hampton Beach Area Master Plan. The scope of work for this effort (herein referred to as the 2018 update) was limited in nature and focused specifically on improving multi-modal mobility and transportation safety in the project area.

The 2018 update composed of two parts. Part A involved updating the transportation existing conditions within the project area and then conceptualizing potential roadway alternatives with emphasis on mobility, safety, and quality of life for all users of the transportation system, including residents, business owners, and visitors. At the end of Part A, several transportation improvement alternatives were identified, vetted with the HBAC and the public, and moved forward to Part B, where the alternatives were further examined for feasibility and cost through a preliminary engineering assessment.

This report summarizes the findings of the 2018 update and the recommendations supported by the HBAC and provides a potential outline of priorities for construction and associated cost estimates for planning purposes. As mentioned above, the intent of this 2018 update is to further evaluate and refine the strategies outlined in the 2001 Master Plan. The analysis and plans developed at this stage are preliminary in nature. Further data collection, analysis, documentation, engineering design, and permitting will be required to bring the concepts to implementation. As funding becomes available to move portions of the plan into official

projects, the comments and input from the stakeholders will be taken into consideration, addressed, and used to modify the plans accordingly.

More detailed information on this 2018 update can be found in the following documents that were prepared throughout the project process:

- Existing Conditions Transportation Summary, April 8, 2015, VHB
- Alternatives Development Transportation Summary, September 9, 2015, VHB
- Future Conditions, Traffic Operational Analysis Summary, September 10, 2015, VHB
- Alternatives Development Transportation Summary, March 8, 2016, VHB
- Existing Conditions Transportation Summary – Expanded Study Area, May 19, 2016, VHB
- Response to HBAC Comments, November 9, 2016, VHB

2

Existing Conditions

As a result of the 2018 update, the Transportation sections of the 2001 Master Plan have been updated to reflect this recent work effort. The following Existing Conditions section has been updated where new information is available; however, where items were not updated (such as average daily traffic and speed counts) the original 2001 plan content remains in place. More detailed information on the existing conditions associated with the 2018 update can be found in VHB's Technical Memorandums titled Existing Conditions Transportation Summary, April 8, 2015 and Existing Conditions Transportation Summary – Expanded Study Area, May 19, 2016.

Introduction

The Transportation section of the Hampton Beach Master Plan project provides a solid understanding of the existing transportation infrastructure present on the corridor, including traffic volumes, truck percentages, and travel speeds. Parking, transit and pedestrian information was also collected and analyzed. Finally, travel safety issues were identified.

Study Area

Based on conversations with the Hampton Beach Master Plan Advisory Committee and analysis of the original study area, a more extensive study area was selected for this project. The study area identified in the 2001 plan extends from the Hampton/Seabrook town line near the Hampton River Bridge to the south up to and including the

intersection of Route 1A and High Street to the north along Route 1A. For a portion of the study area, Route 1A (Ocean Boulevard) and Ashworth Avenue form a one-way couplet. Both Ocean Boulevard (northbound) and Ashworth Avenue (which is not Route 1A) (southbound) are included in the study area. Originally, the 2018 update was limited to the segment of Route 1A from State Park Drive through the north limit of the Ocean Boulevard and Ashworth Avenue one-way couplet. However, in March 2016 the HBAC requested that the study area be extended further north on Route 1A to Winnacunnet Road. The 2018 update study area and expanded study area are shown in Figures 1A and 1B.

State Park Drive, Duston Avenue/Dover Avenue, Ashworth Avenue, Highland Avenue, Church Street, Route 101E (Winnacunnet Road), and Route 27 (High Street) intersect Route 1A (Ocean Boulevard), an urban arterial, to form the study area intersections.

Route 1A (Ocean Boulevard) and State Park Drive

The intersection of Ocean Boulevard and State Park Drive is a typical “T” type, unsignalized intersection located in the southern end of the study area. State Park Drive, the stop-controlled approach, intersects Ocean Boulevard from the east and has designated left and right turn lanes. At this point, Ocean Boulevard is used as one wide travel lane in each direction.

Route 1A (Ocean Boulevard/Ashworth Avenue), Duston Avenue, and Dover Avenue

The intersection of Route 1A, Duston Avenue, and Dover Avenue is a five-way, unsignalized intersection located 0.1 miles north of State Park Drive. Duston Avenue intersects Route 1A from the west and Dover Avenue intersects Route 1A from the east. Ashworth Avenue approaches the intersection from the north and Ocean Boulevard exits the intersection to the north. On the southern side of the intersection, Route 1A is a two-way roadway. There is a U-turn located in the center of the intersection where southbound traffic on Ashworth Avenue may reverse direction to head northbound onto Ocean Boulevard. Duston and Dover Avenues both consist of one travel lane in each direction.

Route 1A (Ocean Boulevard) and Highland Avenue

The intersection of Route 1A and Highland Avenue is located just north of the northern terminus of Ashworth Avenue, where Route 1A becomes Ocean Boulevard with 2 lanes northbound and 2 lanes southbound that are divided by a center parking facility. Highland Avenue is one way eastbound and intersects Route 1A with a through lane (that crosses Route 1A southbound to access either the center parking field or turn left on to Route 1A northbound) and a right-turn lane. Vehicles exiting from Highland Avenue



Figure IA - 2018 Transportation Update Study Area

Hampton Beach Transportation Master Plan Update
Town of Hampton, NH



Figure IB - Expanded 2018 Transportation Update Study Area

Hampton Beach Transportation Master Plan Update
Town of Hampton, NH

operate under stop control. Access to the beach is provided at this location so pedestrian crossings are located on both Route 1A and Highland Avenue.

Route 1A (Ocean Boulevard) and Church Street

The intersection of Ocean Boulevard and Church Street is an unsignalized, “T” type intersection located 0.75 miles north of State Park Drive. In this area, Route 1A is a divided roadway with parking provided in the center. Church Street intersects Ocean Boulevard from the west and leads one-way traffic away from the intersection. Ocean Boulevard is separated by a median containing parking areas. There is a U-turn located within the intersection where northbound traffic on Ocean Boulevard may reverse direction to head southbound. Traffic making the U-turn may queue in the median, which is an extension of Church Street.

Route 1A (Ocean Boulevard) and Route 101E (Winnacunnet Road)

Ocean Boulevard and Winnacunnet Road meet at an unsignalized, T-type intersection (see Figure 2 for intersection layout). Winnacunnet Road intersects Ocean Boulevard from the west approximately 1.5 miles north of State Park Drive and is under stop control. Ocean Boulevard southbound consists of one travel lane where traffic is not permitted to turn onto Winnacunnet Road, as traffic bound for Winnacunnet Road is separated out of the traffic stream prior to reaching the intersection. Winnacunnet Road eastbound is divided by an island before it meets with Ocean Boulevard where northbound traffic will cross Ocean Boulevard southbound before proceeding northbound, and where southbound traffic which merges right will merge onto Ocean Boulevard southbound.

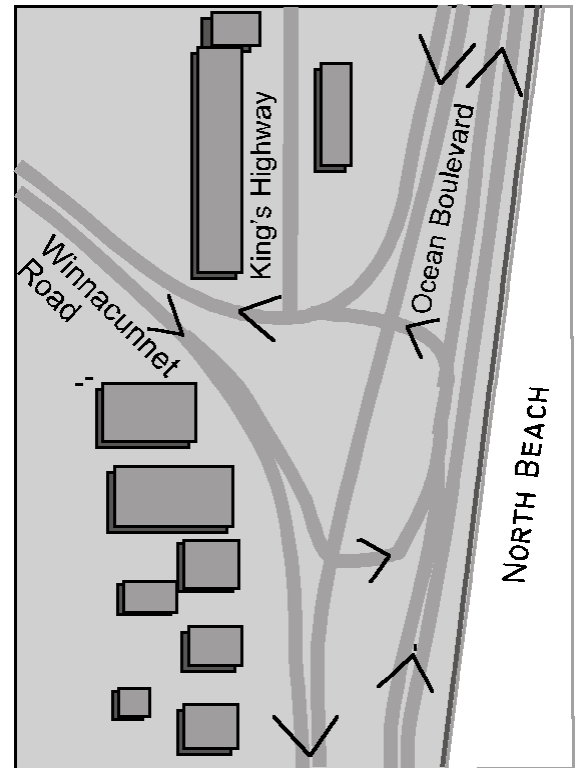

Figure 2. Intersection at Ocean Boulevard and Winnacunnet Road

Ocean Boulevard northbound consists of two through lanes and a left to Winnacunnet Road westbound. Ocean Boulevard southbound consists of a through lane and a right turn lane that leads to Winnacunnet Road westbound. Throughout this intersection, directional traffic is separated by a median that also provides a place for left-turning traffic to queue

Route 1A (Ocean Boulevard) and Route 27 (High Street)

The intersection of Route 1A and High Street is a four-way signalized intersection. Route 1A northbound has a designated left turn lane in addition to a through lane. Route 1A southbound has a right turn lane to access High Street separated from through traffic by a raised island. High Street also has designated left turn lanes for both eastbound and westbound traffic. The eastern leg of the intersection, which consists of one lane in each direction, provides access to a parking area.

Traffic Volumes

To determine the base traffic conditions, traffic volume data was collected on all major roadways and at study area intersections. Automatic traffic recorders and turning movement counts were used to collect this information.

Automatic traffic recorder (ATR) counts were conducted in two independent studies along Route 1A. The first of these two studies were conducted with HI-STAR unit number 8343 in seven locations. Information was gathered at six of these locations: 566 High Street, 580 Winnacunnet Road, Ocean Boulevard at Hampton River Bridge, Route 101 at Glade Path, Main Beach Area, and North Beach. This study was conducted over an 84-hour period in 15-minute intervals in August 2000 to obtain average Thursday, Friday, Saturday, and Sunday traffic volumes. The seventh location data were collected on Ashworth Avenue and Ocean Boulevard at the Casino area over a 59-hour period in 15-minute intervals in August 2000 to obtain representative Monday, Tuesday, and Wednesday traffic volumes. The weather was clear and hot during all data collection.



Summer afternoon traffic on Ocean Boulevard.

The second ATR study was conducted at four locations: Ocean Boulevard between G & H Streets, Ocean Boulevard south of Route 101E, Ashworth Avenue between G and H Streets, and Ocean Boulevard north of Route 27. This study was conducted for 72-hour periods in August 2000 to obtain Saturday, Sunday, and weekday volumes for summer condition. The daily volumes for the locations associated with the two studies are displayed in Table 1 and are represented in Figure 3.

Figure 3. Average Daily Traffic Volumes at Major Intersections Along Ocean Boulevard

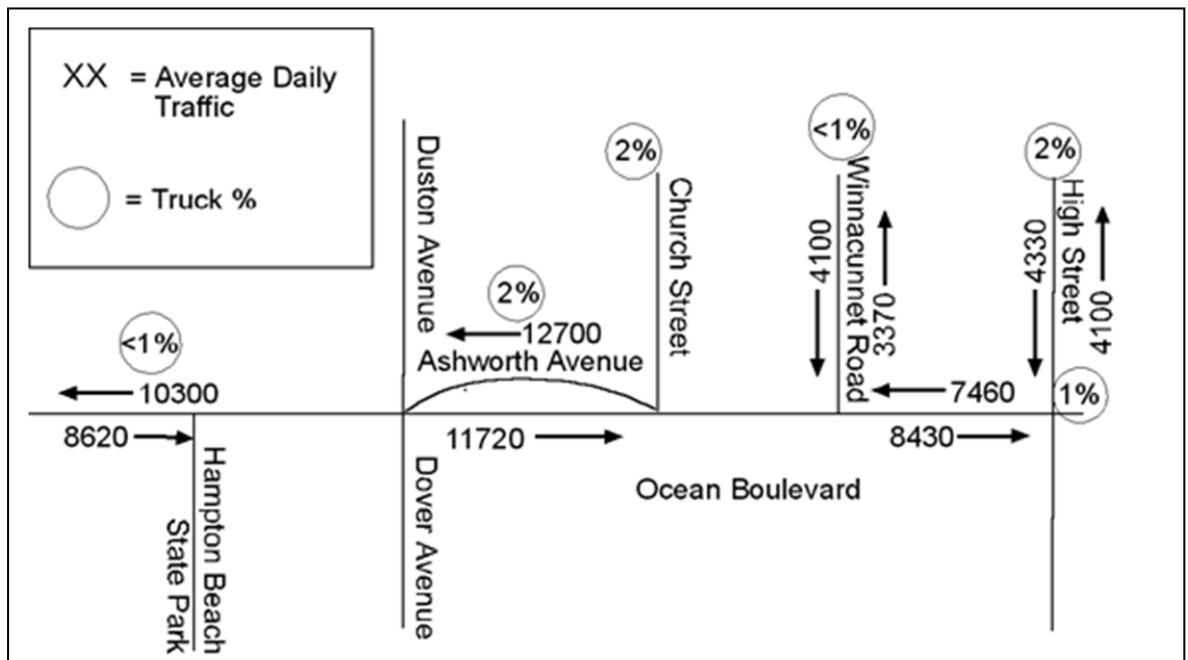

Table 1. ATR Counts

Location	Days Counted	ADT (vpd)
566 High Street	Thursday 8/24/00 – Sunday 8/27/00	8426
580 Winnacunnet Road	Thursday 8/24/00 – Sunday 8/27/00	7460
Ocean Boulevard at Hampton River Bridge	Thursday 8/17/00 – Sunday 8/20/00	18920
Route 101 at Glade Path	Thursday 8/17/00 – Sunday 8/20/00	17344
Main Beach	Thursday 8/17/00 – Sunday 8/20/00	36264
North Beach	Thursday 8/24/00 – Sunday 8/27/00	24409
Ashworth Ave./Ocean Blvd. at Casino Area	Monday 8/21/00 – Wednesday 8/23/00	15885
Ocean Boulevard between G and H Streets	Saturday 8/26/00 – Monday 8/28/00	10938
Ocean Boulevard south of Route 101E	Saturday 8/26/00 – Monday 8/28/00	13017
Ashworth Avenue between G and H Streets	Saturday 8/26/00 – Monday 8/28/00	15839
Ocean Boulevard north of Route 27	Saturday 8/26/00 – Monday 8/28/00	31809

Truck Volumes

The existing percentages of trucks (greater than three axles) included in the daily traffic volumes were determined. In general, the study area traffic consists of two-percent trucks. One location, Ocean Boulevard at High Street, consists of only 1 percent trucks. Two locations, Ocean Boulevard at Hampton River Bridge and Winnacunnet Road, consisted of less than 1 percent trucks. Truck percentages are displayed in Figure 3.

Peak Hour Volumes

To determine the existing traffic volume demands and flow patterns in the project area, a traffic volume count program was conducted in August 2014. Specifically, turning movement counts (TMCs) were conducted at 18 study area intersections on Saturday August 9 and Saturday August 16 during the midday peak period (10:00 AM to 2:00 PM) and the evening peak period (5:00 PM to 8:00 PM). These days were selected as they both enjoyed good beach weather. Count data included cars, trucks, buses, and pedestrians.

Existing Saturday morning and evening peak hour volumes are illustrated in Figures 4A and 4B for vehicular traffic and Figures 4C and 4D for pedestrians.

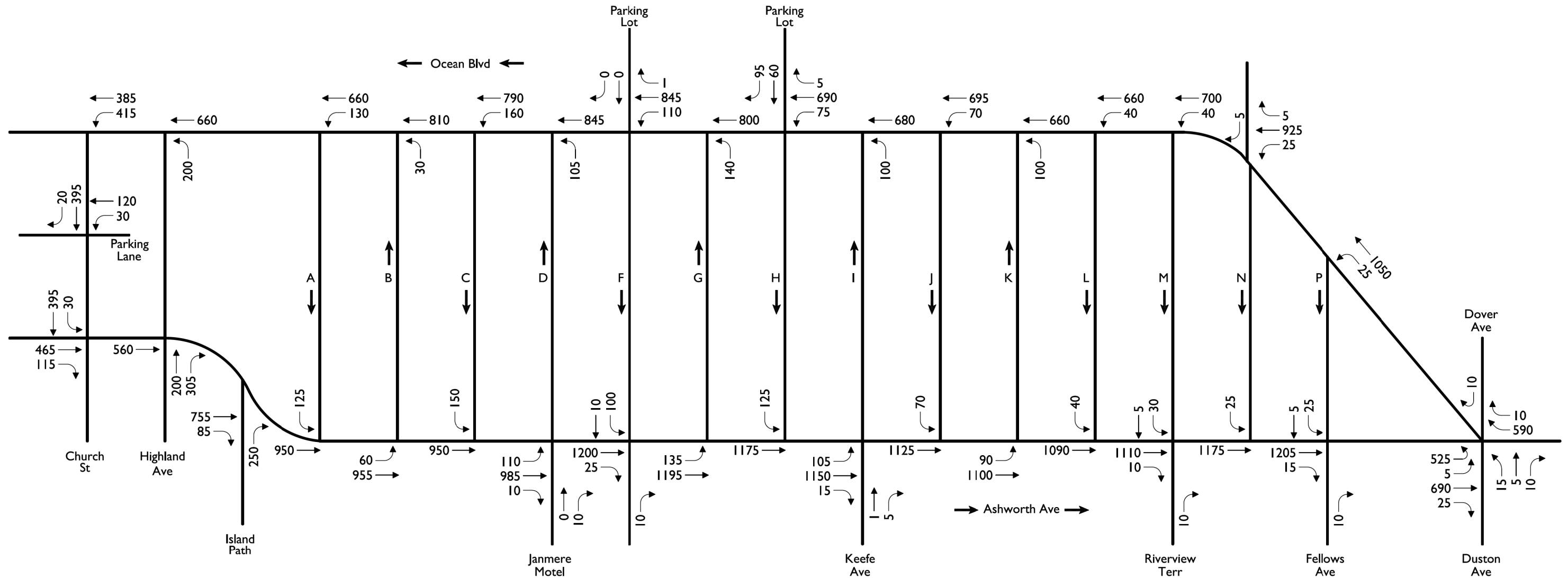

Not to Scale



Figure 4A
2014 Saturday Midday (10:45 AM)
Peak Hour Traffic Volumes

**Hampton Beach Transportation
Master Plan Update**
Town of Hampton, NH

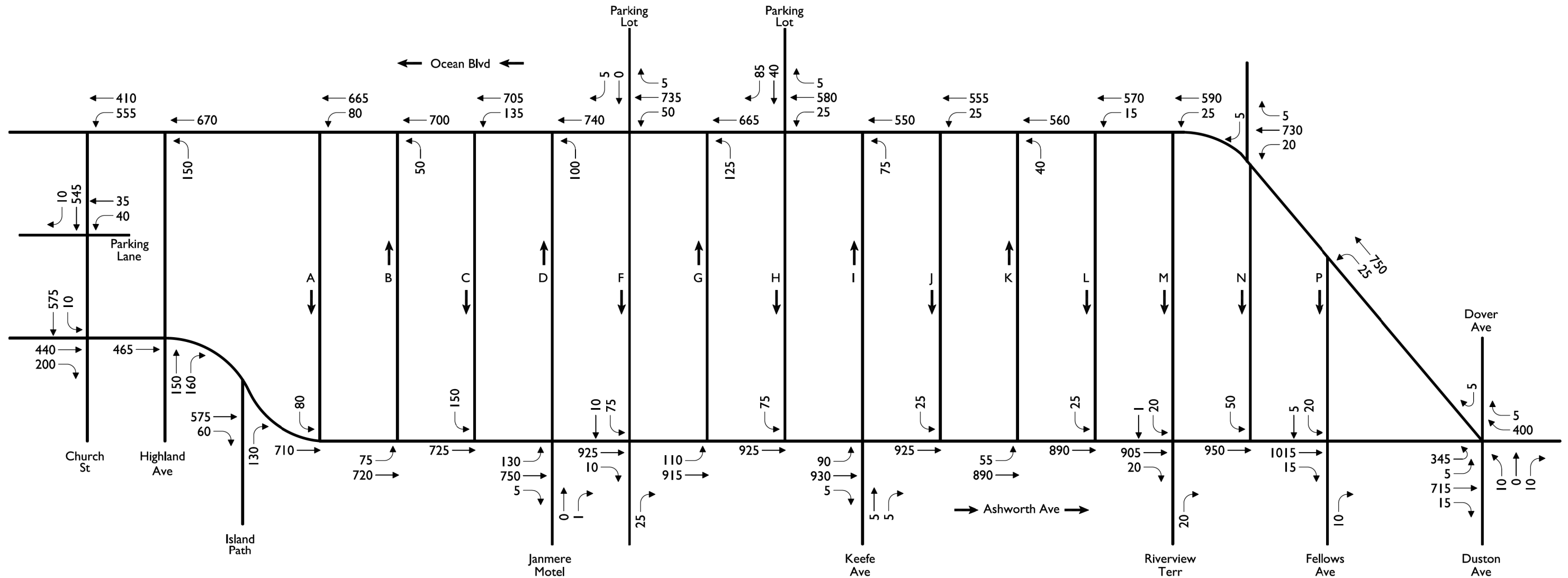

Not to Scale



Figure 4B
2014 Saturday Evening (5:30 PM)
Peak Hour Traffic Volumes

**Hampton Beach Transportation
Master Plan Update**
Town of Hampton, NH

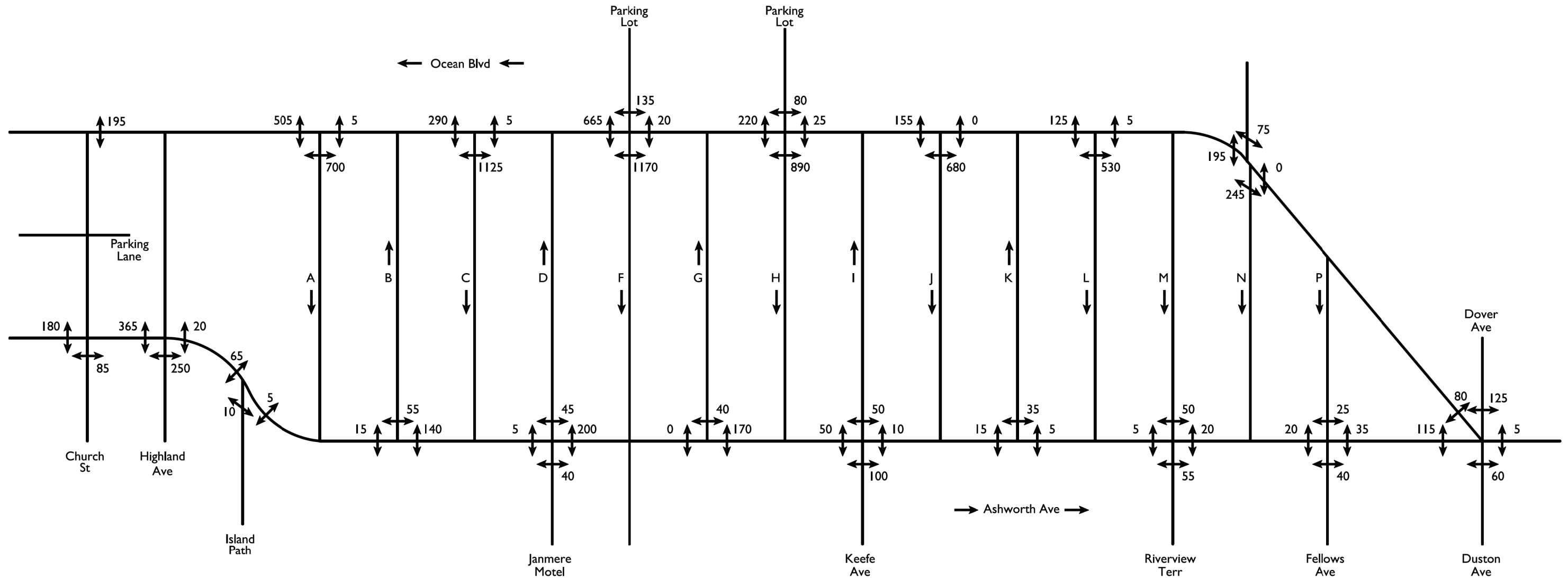

Not to Scale



Figure 4C
2014 Saturday Midday (10:45 AM)
Peak Hour Pedestrian Volumes

**Hampton Beach Transportation
Master Plan Update**
Town of Hampton, NH

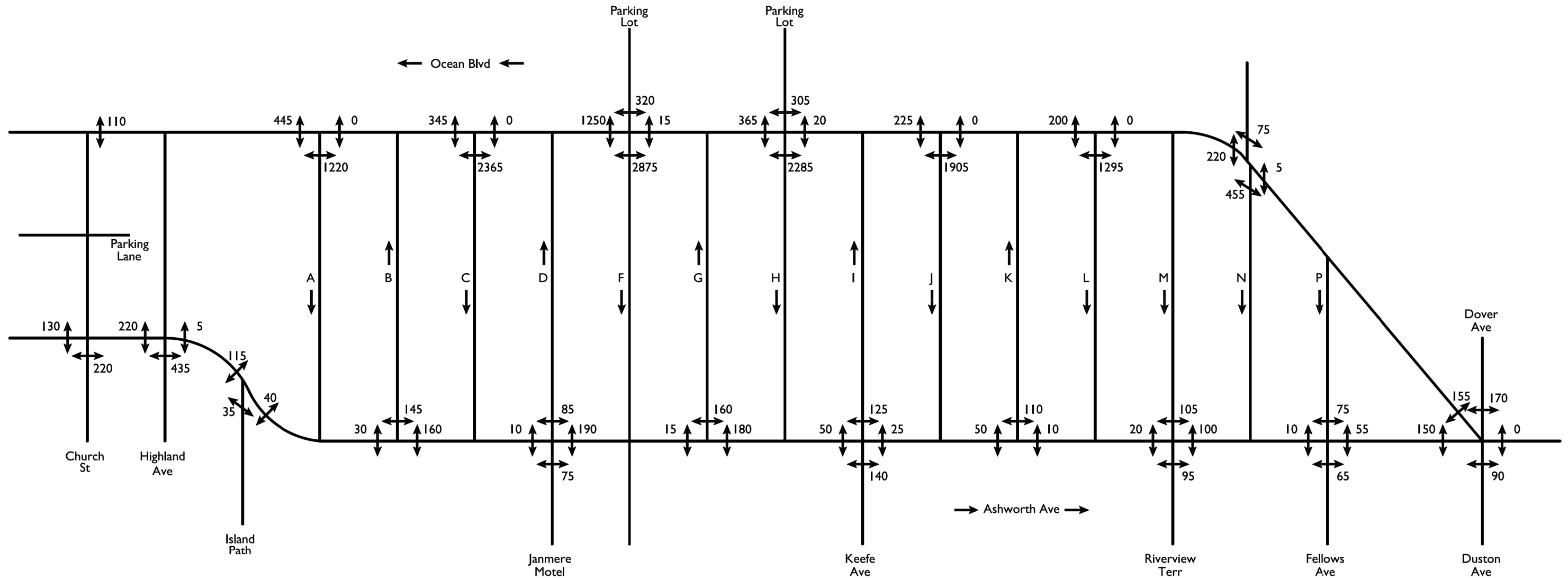

Not to Scale



Figure 4D
 2014 Saturday Evening (5:30 PM)
 Peak Hour Pedestrian Volumes

**Hampton Beach Transportation
 Master Plan Update**
 Town of Hampton, NH

Travel Speeds

The vehicle speeds measured on major roadways in the study area are described below and are shown on Figure 5. The speed limits for each link are also illustrated on this figure and are described below.

Speed limits with the study area are generally observed on Ashworth Avenue, High Street, Winnacunnet Road, and most parts of Ocean Boulevard. Vehicles traveling south on Ocean Boulevard have a tendency to exceed the limit south of Dover Avenue. This area may need additional enforcement to maintain safe conditions for other pedestrians and vehicles.

There are two posted speed limits for traffic on Ocean Boulevard. On the northern end of the study area the speed limit for Ocean Boulevard is 35 miles per hour (mph). The average speed for vehicles traveling in this area is 29 mph with 9 percent of the vehicles traveling over the speed limit.

In the vicinity of the main beach area, the southbound vehicles on Ashworth Avenue have an average speed of 24 mph, measured over a 24-hour period with 5 percent of the vehicles traveling faster than the speed limit of 35 mph. The northbound vehicles traveling on Ocean Boulevard have an average speed of 28 mph measured over a 24-hour period with 3 percent of the vehicles traveling faster than the speed limit.

Figure 5. Speed Statistics Along Ocean Boulevard in Hampton

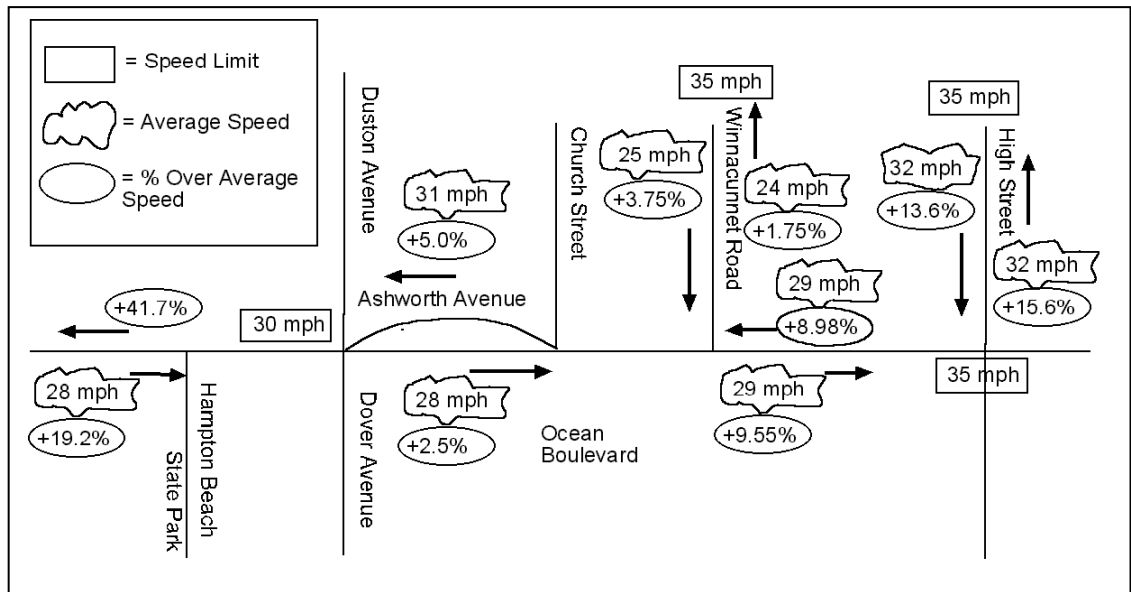

South of Dover Avenue on Ocean Boulevard, the speed limit is posted as 30 mph. The vehicles traveling on Ocean Boulevard in the southbound direction have an average speed of 31 mph and 42 percent of the vehicles travel faster than the speed limit. In the

northbound direction, the vehicles traveling have an average speed of 28 mph and 19 percent of the vehicles are traveling above the speed limit.

The vehicle speeds on High Street were also collected. The posted speed limit for High Street is 35 mph. The average speed for both the east and westbound vehicles is 32 mph. While the percentage of eastbound vehicles traveling faster than the speed limit is 14 percent, the westbound vehicles traveling above the speed limit is 16 percent.

Winnacunnet Road has a posted speed limit of 35 mph. The average speed that was observed for the eastbound vehicles is 25 mph, with 4 percent of the vehicles traveling faster than the speed limit. The westbound vehicles travel at an average speed of 24 mph and have 2 percent of the vehicles traveling above the speed limit.

Parking

Parking data provided by the Rockingham Planning Commission (RPC) has been compiled and updated based on a review of the existing conditions from areal mapping and field reconnaissance. There are numerous parking lots (both public and private) as well as on-street parking throughout the project study area. Public metered parking is available along the east side of Ocean Boulevard between Haverhill Avenue and Nudd Avenue as well as in the median of Ocean Boulevard between Nudd Avenue and Anchor Street (approximately 1,600 feet north of the study area limit). Specifically, the following metered parking is provided along Ocean Boulevard:

- 343 (passenger car) spaces and an additional 21 motorcycle spaces between Haverhill Avenue and the Seashell,
- 73 (passenger car) spaces between the Seashell and Nudd Avenue,
- 137 (passenger car) spaces and an additional 28 motorcycle spaces within the median between Nudd Avenue and Church Street,
- 43 (passenger car) spaces within the median just north of Church Street (still within the project study area),
- 274 (passenger car) spaces located within 5 separate median lots between Church Street and Great Boars Head Avenue, and
- 132 (passenger car) parallel spaces located adjacent to the center median between Dumas Avenue and Winnacunnet Road.

Other significant public parking lots include the State Park lot (1,000 spaces) and the State Marina lot (approximately 100 spaces) to the south, the Casino (366 spaces) and the Police Department lot (313 spaces) in the central portion of the study area, and the Town Dirt lot (305 spaces), the Island Path lot (230 spaces), and the Sands lot (289 spaces) to the north. The public and private parking lots within and around the project study area and expanded study area are shown in Figures 6A and 6B.

MAP ID	LOCATION	VEHICLE CAPACITY	MOTORCYCLE CAPACITY	AVERAGE AVAILABILITY(1)
1	TOWN DIRT LOT	305	N/A	178
2	ISLAND PATH	230	N/A	99
3	SANDS	289	N/A	102
4	HAMPTON BEACH CASINO	366	N/A	37
5	POLICE LOT	313	N/A	93
6	SEA SHELL/OCEAN BLV	343	21	N/A
7	STATE PARK	1000	N/A	685
8	HAMPTON BEACH STATE MARINA	100*	N/A	N/A
9	NORTH OF SHELL	73	N/A	N/A
10	MEDIAN	11	N/A	1
11	MEDIAN	35	28	6
12	MEDIAN	48	N/A	2
13	MEDIAN	43	N/A	1
14	MEDIAN	43	N/A	3
15	MEDIAN (NORTH OF STUDY AREA)	44	N/A	4
16	MEDIAN (NORTH OF STUDY AREA)	62	N/A	13
17	RIVER AVE/OCEAN BLV	10	N/A	N/A
18	HAVERHILL AVE	12	N/A	N/A
19	SOUTH OF POLICE LOT	100	N/A	N/A
20	OLD FIRE STATION	63	N/A	N/A
21	C STREET	78*	N/A	N/A
22	B STREET	59*	N/A	N/A
23	A STREET	86*	N/A	N/A
24	CHURCH STREET	100*	N/A	N/A
ADDITIONAL MEDIAN LOTS (NORTH OF STUDY AREA)		139	N/A	76

(1) RPC 2011 Parking Study

* Vehicle Capacity Approximated from Aerial Photography

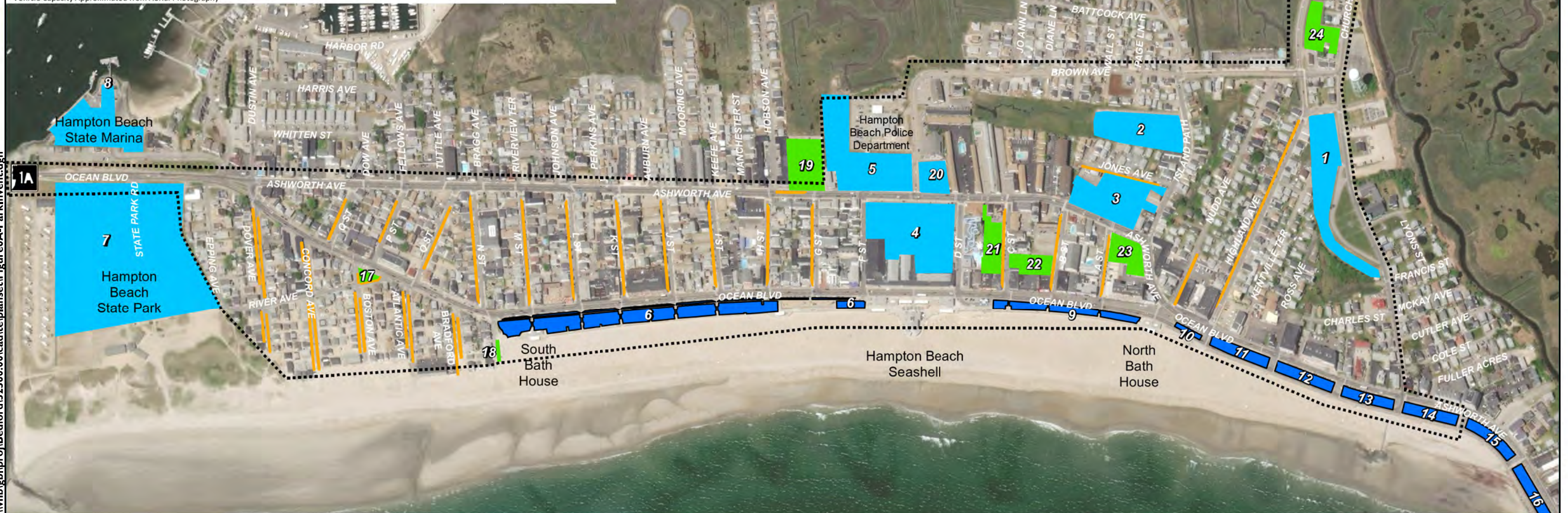

Legend

- Study Area
- Parking Inventory**
- Public Parking
- Metered Parking
- On street Parking
- Shoulder Signed As No Parking Except to Load/Unload
- Shoulder Used for Parking/Loading/Unloading
- Private Parking Lot

Source:
 1. 2011 RPC Parking Inventory.
 2. VHB field review 2014/2015.

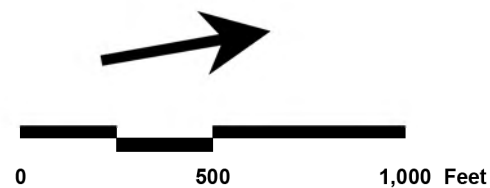

Figure 6A - Parking Inventory



Map ID	Vehicle Capacity
14	43
15	45
16	62
17	71
18	53
19	7
20	34
21	37
22	14
23	16
24	9
25	9
26	10

Note: Parking utilization data not available - Beyond the limits of the 2011 RPC Parking Inventory.

Legend

- Study Area
- Parking Inventory**
 - Public Parking
 - Metered Parking
 - On street Parking

Source:

1. 2011 RPC Parking Inventory
2. VHB field review 2014/2015

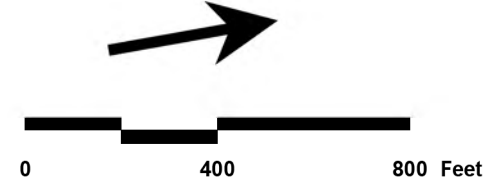

Figure 6B - Parking Inventory Expanded Study Area

Operating Conditions

Existing peak hour traffic operations in the project study area were determined. Specifically, intersection operating levels of service were calculated as described in greater detail below.

Level of Service Criteria

Unsignalized intersection capacity analyses were performed for the study area intersections. Levels of service (LOS) were calculated based on the criteria published in the *2000 Highway Capacity Manual*, published by the Transportation Research Board. Level of service is the term that defines the conditions that may occur on a given roadway or at an intersection when accommodating various traffic volume loads. Levels of service range from A to F with LOS A representing the best operating conditions and LOS F representing the worst. The criteria for establishing LOS at unsignalized intersections is based on the amount of delay experienced by vehicles exiting from side streets and assumes that flow along the mainline is uninterrupted. This is important to note as the results represented herein for the existing condition may not necessarily reflect the actual condition where the lack of defined (attractive) pedestrian crossings within the study area plays a role in the overall function of the roadway system. The LOS thresholds for unsignalized intersections based on the Highway Capacity Manual methodology are summarized Table 2.

Table 2. LOS Criteria for Unsignalized Intersections

LOS	Average Control Delay
A	0 - 10 seconds per vehicle
B	> 10 - 15 seconds per vehicle
C	> 15 - 25 seconds per vehicle
D	> 25 - 35 seconds per vehicle
E	> 35 - 50 seconds per vehicle
F	> 50 seconds per vehicle

The 2014 existing conditions unsignalized intersection capacity analysis results for the 35 study area intersections are summarized in Table 3. As shown, 10 of the 35 intersection's minor street approaches currently operate at LOS F during the Saturday midday and/or the Saturday evening peak hour conditions. Long delays at these locations are the result of heavy vehicular volumes and pedestrian flows along Ocean Boulevard and Ashworth Avenue during peak summer month conditions. However, it is important to point out that LOS F

operations doesn't necessarily indicate "failing" conditions. Actually, the heavy vehicle and pedestrian activity is an indication of the successful draw of patrons to the beach and businesses in the study area.

It should be noted that the 95th percentile peak hour queues exceed the available storage at the following study area locations:

- The westbound movement approaching Church Street through the parking lot (between Ocean Boulevard northbound and southbound) backs up onto Ocean Boulevard northbound;
- The eastbound movement from Highland Avenue through the parking lot (between Ocean Boulevard northbound and southbound) backs up onto Ocean Boulevard southbound and Highland Avenue;
- The westbound movement from the parking lot located on the east side of Ocean Boulevard opposite F Street backs up internally;
- The westbound movement from the parking lot located on the east side of Ocean Boulevard opposite H Street backs up internally; and
- The eastbound movement from Ashworth Avenue/Dover Avenue approaching Ocean Boulevard backs up onto Dover Avenue and Ashworth Avenue.

This operational analysis indicates that the available storage on these minor street approaches does not accommodate the maximum (95th percentile) queues experienced during peak summer conditions, which results in backups onto the main northbound and southbound travel ways. All other study area intersections operate at better levels of service (LOS E or better), shorter delays (less than 50 seconds) and with queues that are contained in the available storage.

2018 Transportation Master Plan Update – Hampton Beach Area

Table 3. Unsignalized Intersection Capacity Analysis Summary

Location / Movement	Existing Conditions - Peak Month (Summer) Operational Analysis								Storage
	2014 Saturday Midday				2014 Saturday Evening				
	Demand*	Delay**	LOS***	Queue^	Demand	Delay	LOS	Queue	
Church St (101 WB) at Ocean Blvd (1A SB)									
WB shared left/through from parking lot	425	321	F	714	575	837	F	1348	50
Church St (101 WB) at Ocean Blvd (1A NB)									
NB shared left/through from Ocean Blvd	610	7	A	29	760	7	A	42	-
Highland Ave (101 EB) at Ocean Blvd (1A SB)									
EB through from Highland Ave	200	30	D	105	150	17	C	43	-
EB right-turn from Highland Ave	305	41	E	193	160	22	C	63	1100
Highland Ave (101 EB) at Ocean Blvd (1A NB)									
EB left-turn from Highland Ave	200	33	D	113	150	18	C	45	40
Island Path at Ashworth Ave (1A SB)									
EB right-turn from Island Path	250	25	C	102	130	18	C	37	-
A St at Ashworth Ave (1A SB)									
WB left-turn from A St	125	16	C	33	80	14	B	16	350
A St at Ocean Blvd (1A NB)									
NB shared left/through from Ocean Blvd	460	5	A	15	415	5	A	14	-
B St at Ashworth Ave (1A SB)									
SB shared left/through from Ashworth Ave	540	2	A	3	435	2	A	5	-
B St at Ocean Blvd (1A NB)									
EB left-turn from B St	30	37	E	21	50	447	F	145	400
C St at Ashworth Ave (1A SB)									
WB left-turn from C St	150	22	C	57	150	20	C	50	425
C St at Ocean Blvd (1A NB)									
NB shared left/through from Ocean Blvd	555	8	A	27	490	48	E	110	-
D St / Janmere at Ashworth Ave (1A SB)									
EB shared through/right from Janmere	10	18	C	5	1	24	C	3	300
SB shared left/through from Ashworth Ave	610	2	A	6	505	3	A	8	-
D St at Ocean Blvd (1A NB)									
EB left-turn from D St	105	213	F	194	100	#	F	#	425
F St / Parking Lot at Ashworth Ave (1A SB)									
EB right-turn from Parking Lot	10	19	C	3	25	18	C	7	135
WB shared left/through from F St	110	39	E	74	85	29	D	44	425
F St / Parking Lot at Ocean Blvd (1A NB)									
WB shared through/right from Parking Lot	1	135	F	6	5	#	F	#	25
NB shared left/through from Ocean Blvd	540	6	A	21	420	28	D	42	-
G St at Ashworth Ave (1A SB)									
SB shared left/through from Ashworth Ave	735	3	A	8	570	3	A	6	-
G St at Ocean Blvd (1A NB)									
EB left-turn from G St	140	114	F	182	125	#	F	#	425
H St at Ashworth Ave (1A SB)									
WB left-turn from H St	125	19	C	40	75	15	C	18	450

* Demand in vehicles per hour. ** Delay in seconds per vehicle. *** Level of Service.

^ 95th percentile queue expressed in feet. XX - Queue exceeds available storage (ft). # Delay/Queue not calculated due to congestion level.

2018 Transportation Master Plan Update – Hampton Beach Area

Table 3 Continued. Unsignalized Intersection Capacity Analysis Summary

Location / Movement	Existing Conditions - Peak Month (Summer) Operational Analysis								
	2014 Saturday Midday				2014 Saturday Evening				Storage
	Demand*	Delay**	LOS***	Queue^	Demand	Delay	LOS	Queue	
H St / Parking Lot at Ocean Blvd (1A NB)									
WB shared through/right from Parking Lot	155	326	F	292	125	#	F	#	25
NB shared left/through from Ocean Blvd	420	3	A	9	315	5	A	11	-
I St / Keefe Ave at Ashworth Ave (1A SB)									
EB shared through/right from Keefe Ave	5	26	D	4	10	34	D	9	-
SB shared left/through from Ashworth Ave	680	2	A	6	555	2	A	5	-
I St at Ocean Blvd (1A NB)									
EB left-turn from I St	100	51	F	86	75	983	F	245	450
J St at Ashworth Ave (1A SB)									
WB left-turn from J St	70	17	C	19	25	14	B	6	475
J St at Ocean Blvd (1A NB)									
NB shared left/through from Ocean Blvd	420	3	A	7	305	4	A	7	-
K St at Ashworth Ave (1A SB)									
SB shared left/through from Ashworth Ave	640	2	A	5	500	2	A	3	-
K St at Ocean Blvd (1A NB)									
EB left-turn from K St	100	30	D	55	40	157	F	81	500
L St at Ashworth Ave (1A SB)									
WB left-turn from L St	40	15	B	9	25	14	B	5	525
L St at Ocean Blvd (1A NB)									
NB shared left/through from Ocean Blvd	370	2	A	3	300	1	A	2	-
M St / Riverview Ter at Ashworth Ave (1A SB)									
EB right-turn from Riverview Ter	10	16	C	4	20	22	C	27	-
WB shared left/through from M St	35	21	C	13	20	26	D	13	550
M St at Ocean Blvd (1A NB)									
NB shared left/through from Ocean Blvd	390	2	A	3	320	1	A	3	-
N St at Ashworth Ave (1A SB)									
WB left-turn from N St	25	15	B	6	50	14	B	11	575
N St / Haverhill Ave at Ocean Blvd (1A NB)									
WB right-turn from Haverhill Ave	5	19	C	3	5	17	C	2	-
NB shared left/through from Ocean Blvd	490	1	A	2	385	1	A	2	-
P St / Fellows Ave at Ashworth Ave (1A SB)									
EB right-turn from Fellows Ave	10	17	C	8	10	16	C	3	-
WB shared left/through from P St	30	23	C	15	25	20	C	10	375
P St at Ocean Blvd (1A NB)									
NB shared left/through from Ocean Blvd	550	1	A	2	400	1	A	2	675
Duston Ave at Ashworth Ave (1A SB)									
EB shared through/right from Duston Ave	30	301	F	99	20	116	F	60	-
SB left-turn from Ashworth Ave	530	9	A	43	350	8	A	27	475
Dover Ave at Ashworth Ave / Ocean Blvd									
EB shared left/through from Ashworth Ave	550	634	F	1134	360	134	F	397	60
WB right-turn from Dover Ave	10	19	C	7	5	16	C	2	-

* Demand in vehicles per hour. ** Delay in seconds per vehicle. *** Level of Service.

^ 95th percentile queue expressed in feet. XX - Queue exceeds available storage (ft). # Delay/Queue not calculated due to congestion level.

Transit

A review of the existing local public transportation providers (COAST and Wildcat Transit), as well as long distance bus services (C&J, East West Express, The Coach Company), revealed that no scheduled public bus service is currently provided to service the study area.

Scenic Byways

There are two state-designated scenic byways in the Hampton Beach area. A portion of the Independence Byway runs, in part, along Winnacunnet Road, and ends in the southern portion of North Beach. Part of the 18.5-mile **Coastal Byway is along Route 1A in Hampton. It runs from Portsmouth to Seabrook and offers excellent views of the Atlantic Ocean as well as many sandy beaches and historic properties. The byway is popular with motorists, bicyclists, and pedestrians.**

Pedestrian and Bicycle Accommodations

Pedestrians are an important component of the Hampton Beach transportation network. This is illustrated in the large number of crosswalks extending from the beach to the commercial areas on the west side of Ocean Boulevard. These pedestrian crossings contribute significantly to the slow traffic conditions experienced by motorists along Ocean Boulevard.

Sidewalk of varying width is provided on both sides of Ocean Boulevard. However, it should be noted that numerous sections of sidewalk along the west side of Ocean Boulevard particularly in the southern portion of the study area are flush with the shoulder and/or provide limited vertical delineation between the shoulder and the sidewalk. This lack of physical and visual separation between pedestrians and motor vehicles (including delivery trucks using the shoulder) is a safety concern.

Lack of delineation between sidewalk and shoulder along Ocean Boulevard.



Many of the pedestrian crossings, primarily on the west side of Ocean Boulevard, do not have Americans with Disability Act (ADA) compliant pedestrian ramps. Deficiencies along the west side of Ocean Boulevard include a lack of striped crosswalks at most north-south pedestrian crossings, no pedestrian ramps at several pedestrian crossings, and a lack of Detectable Warning Surfaces (DWS) on numerous pedestrian ramps.



Lack of north-south crosswalks and pedestrian ramps with DWS along the west (left) side of Ocean Boulevard.

Along Ashworth Avenue, 4 foot to 5 foot sidewalk is provided on both sides of the street except on the west side between Island Path and C Street where the sidewalk is only 2.5 feet to 3 feet wide and has numerous utility poles located within it. North-south pedestrian crossings located on the west side of Ashworth Avenue generally lack striped crosswalks and DWS are nonexistent at all but one location (northern side of Brown Avenue) on both sides of Ashworth Avenue.



Narrow sidewalk with utilities along Ashworth Avenue.

Experienced cyclists traveling along Ocean Boulevard and Ashworth Avenue tend to utilize the shoulders on the right side of the travel way. However, because numerous sections of these shoulders are used for parking and/or truck loading, cyclists are often forced into the travel way, which carries high traffic volumes during the peak summer months. Highland Avenue (Route 101 eastbound) provides a 3-foot bike lane, which is the only striped bike lane within the project study area. By most guidelines, a 3-foot bike lane adjacent to vertical curbing and an 11-foot travel lane (as shown in Exhibit 4) is not considered to be adequate.

Inexperienced cyclists, including children and in many cases tourists, likely find the major roadways within the project study area (Ocean Boulevard, Ashworth Avenue, Highland Avenue, and Church Street) intimidating to ride on due to high traffic volumes, varying shoulder widths, and conflicts with vehicles utilizing the shoulders for parking and/or loading. As a result, there can be a mixing with pedestrians on the sidewalks. The majority of the sidewalks do not accommodate both users safely. However, east of Ocean Boulevard adjacent to the beach, wide multiuse walkways accommodate pedestrians and recreational bicyclists between Haverhill Avenue and Highland Avenue. Bicycle racks are provided at a few locations along the east side of Ocean Boulevard (next to the bath house opposite M Street, just south of the playground opposite H Street, and next to the bath house opposite Nudd Avenue). Figures 7A and 7B show the existing sidewalks, shoulders, and bike lanes within the project study area.



Three-foot striped bike lane adjacent to vertical curb along Highland Avenue.

Safety Issues

Throughout the majority of the transportation-related interviews, safety concerns were not mentioned. Therefore, the Hampton Police Department was contacted regarding safety concerns along the Hampton Beach corridor and observations were made regarding existing safety conditions.

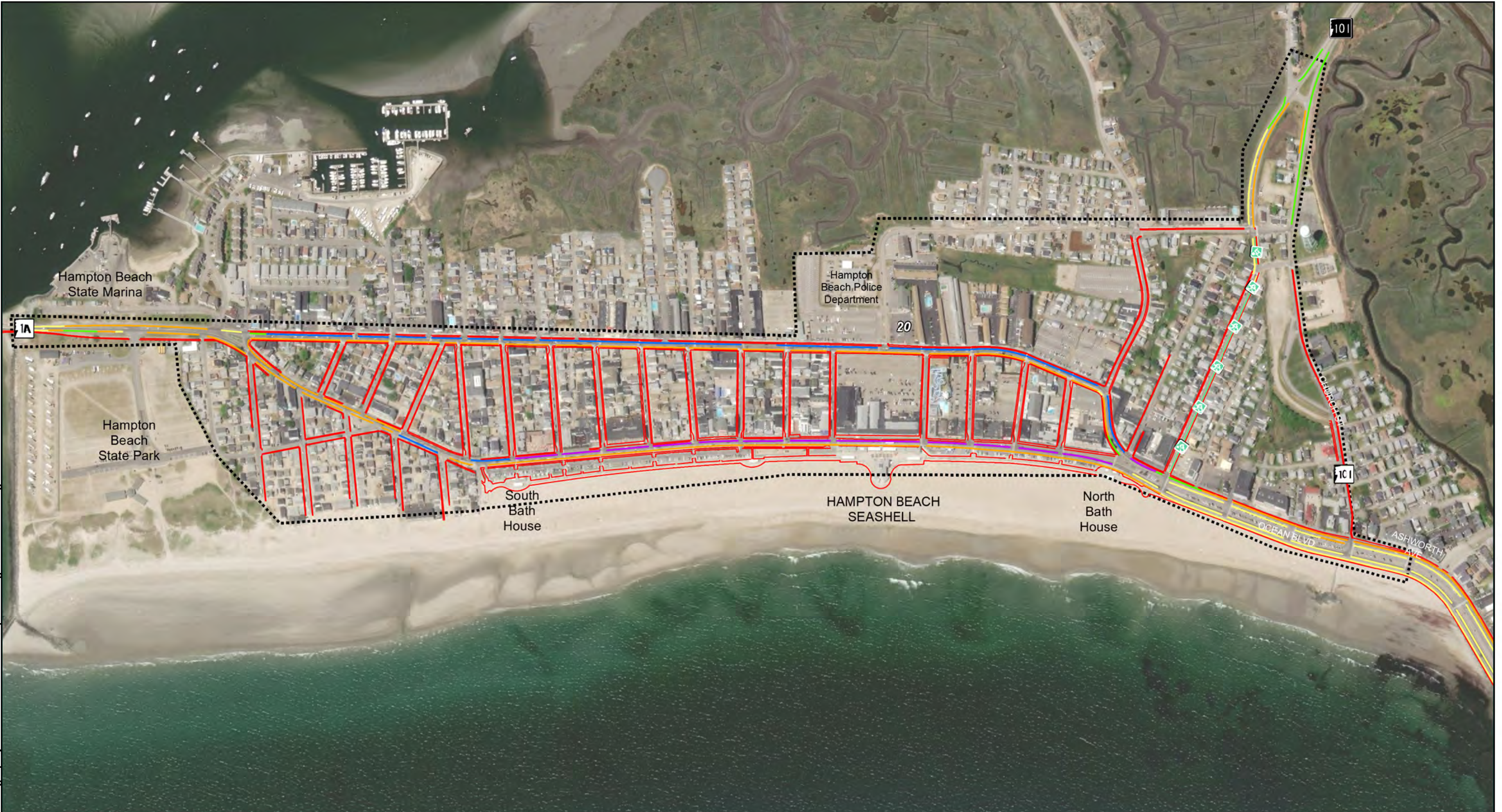

Legend

Study Area

Existing Conditions Inventory

Striped Bike Lane

Sidewalk

2-ft Shoulder

4-ft Shoulder

6-ft Shoulder

8-ft Shoulder

10-ft Shoulder

Source:
1. 2013/2014 aerial photography.
2. VHB field review 2014/2015.

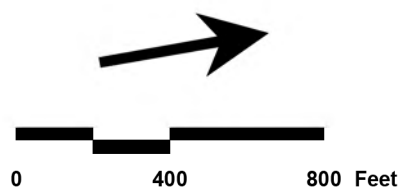

Figure 7A - Bicycle & Pedestrian Facilities



- Legend
- Study Area
- Existing Conditions Inventory
- Striped Bike Lane
 - Sidewalk
 - 2-ft Shoulder
 - 4-ft Shoulder
 - 6-ft Shoulder

Source:
 1. 2013/2014 aerial photography
 2. VHB field review 2014/2015.

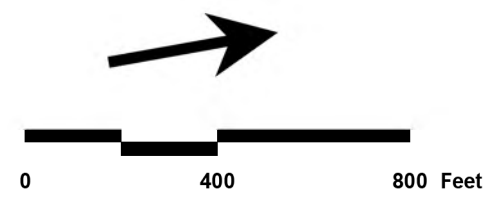

Figure 7B - Bicycle & Pedestrian Facilities Expanded Study Area

Incidents

As indicated above, the traffic along the Beach is traveling at low rates of speed due to the large volumes of pedestrian crossings in addition to vehicles parking and exiting. These low speeds create a safer condition for pedestrians and vehicles alike. The accidents that occur during the day tend to be rear-end accidents and typically not serious. Accidents that are more serious occur at night when traffic speeds are high. According to the Hampton Police Department, during the day the congested condition contributes to some road rage.

Emergency Vehicle Access

One significant safety concern in the Hampton Beach area is emergency vehicle access. During congested periods, emergency vehicles, including vehicles from the police and fire station on Brown Avenue, have trouble accessing properties along the beach. Since the beach traffic also exists on Ashworth Avenue, it can impact the response time of emergency vehicles to non-beach areas as well. Currently, a traffic light exists on Ashworth Avenue to stop the traffic and allow fire response vehicles to exit the station and travel the wrong way on Ashworth Avenue to access D Street and reach points north. The police response vehicles access the north via G Street but will travel the wrong way on Ashworth from F Street in order to return to the station. These patterns have developed to minimize the congestion that the emergency response vehicles encounter.

Special Events

Traffic circulation is changed for some special events. Sometimes, portions of Ocean Boulevard are closed, and the police department works to reroute traffic. This road closure is met with mixed results. The traffic backs up significantly in each direction, but the large volume of pedestrian traffic is able to move about freely.

Seafood Festival

During the Seafood Festival, Ocean Boulevard is closed from H Street up to the u-turn to Ashworth Avenue. A high usage of off-site parking lots minimizes the traffic congestion to some extent. In addition, a number of mitigative actions are taken to move traffic along.

Traffic officers and volunteers control the traffic along Ocean Boulevard. The traffic on Ocean Boulevard is reduced to one lane in the vicinity of I and J Streets to accommodate the Ocean Boulevard traffic on H Street and Ashworth Avenue. The Ocean Boulevard traffic is then directed down H Street and accommodated in the northbound direction on Ashworth Avenue. The Hampton Police Department has verified that during this traffic modification, there are a number of congested areas.



View of the Seafood Festival, 2000 looking north on the closed portion of Ocean Boulevard.

Fourth of July

During the Fourth of July celebration, an additional area of congestion is created by the opening and closing of the Hampton River Bridge. The Police Department has attempted to mitigate this problem by using lighted signs to direct motorists to use Route 101 to access Route 95 instead of the bridge. However, the access to Route 101 via the beach is Church Street, a narrow one-lane roadway, severely limiting the capacity of this route. To increase the volume that can exit via Route 101, the Police Department has created temporary lane markings, signage and police control, as described below.

At the ending of the fireworks display on July 4, 1999, the Hampton Police Department set up traffic diversions to ease the congestion of traffic in the westbound direction of Route 101. There was a police officer directing traffic on Route 101 at the intersection of the Town parking lot. Traffic was directed 12 feet to the right by the officer and by traffic cones placed on the road, creating a left turn entrance lane for Brown Avenue, where there is another police officer directing traffic. Traffic continued down Route

101 in two lanes. There were signs along the side of the road directing motorists to stay in two lanes. To add additional space needed for two lanes of travel in the westbound direction, cones were placed three feet south of the centerline, limiting the width of the eastbound travel lane. The two travel lanes and the cones continue to the intersection of Landing Road where there were two officers directing traffic. At the intersection of Landing Road, the existing three lanes of traffic in the westbound direction were reallocated to allow through movements from the right turn only lane. 900 feet beyond the intersection of Landing Road, to the west, the travel lanes merged to one in the westbound direction.

Along Route 101, there were temporary signs to assist with the directing of traffic. The first were placed after the intersection with Brown Avenue, directing motorists to “Form Two Lanes.” As the westbound traffic reached the east and westbound split of Route 101, there were signs on either side of the road stating, “Stay In Two Lanes.” Covers were also placed over permanent signs stating that, “Travel On Shoulders Prohibited, Emergency Stopping Only.”

During the public meeting process for the 2018 update, the HBAC members made a special acknowledgment that the Police Department does an excellent job of clearing the traffic from the beach safely and expediently after special events such as the fireworks.

3

Recommendations

The Transportation components of the master plan were updated in 2018 with the goal of:

- Further vetting the transportation strategies and concepts presented in the 2001 plan for feasibility;
- Considering current demands and needs within the project area for all users, including residents, business owners and visitors; and
- Developing updated improvement alternatives that could be progressed into a preliminary engineering review;
- Assessing planning-level costs for the updated recommendations; and
- Creating a framework for phasing and implementing the recommendations from the 2018 plan update.

The 2018 update process included a public involvement and outreach process, which helped to form consistent themes, identify issues and concerns, and set priorities. Outcomes of the public involvement process included clear direction that:

- The 2001 recommendation to eliminate the existing one-way circulation couplet formed by Ashworth Avenue (southbound) and Ocean Boulevard (northbound) was no longer desirable. (More details provided following herein.)

- Formalizing and emphasizing pedestrian and bicycle accommodations remains a high priority.
- All roadway improvement plans must provide drainage infrastructure to eliminate or minimize the potential for street flooding on both Ocean Boulevard and Ashworth Avenue.
- Protecting the view of the ocean from Ocean Boulevard is a high priority.

The HBAC supports these priorities, which are reflected in the recommendations presented in this section. It should be noted that the following sections have intentionally been written so that the recommendations for each roadway segment could be read individually and still reflect the context of the overall plan (therefore, reading this chapter as a whole may seem repetitive).

Ashworth Avenue

2018 Investigations and Recommendations

During the 2018 Master Plan update process, the two-way, three lane concept plan (one travel lane in each direction with a center turn lane) from the 2001 plan was further vetted for feasibility. In addition, a second two-way alternative for Ashworth Avenue that considered two southbound lanes and one northbound lane was also investigated and presented to the HBAC and the public early in the process. Both alternatives included sidewalk on both sides of the roadway and installation of a traffic signal at the Ocean Boulevard/Duston Avenue/Dover Avenue intersection. However, they did not account for a separate, formal bike lane due to width limitations.

While each of the two-way concepts appear to be a potential option, input from the public, the Hampton Beach Area Commission (HBAC) and various state and local stakeholders indicated that this change in circulation was no longer desirable. More specifically, concerns were raised regarding emergency services and response times under the two-way concept. Additional concerns were discussed with regard to flooding on Ashworth Avenue and the need to keep Ocean Boulevard two lanes to accommodate traffic flow under flood conditions. **The final direction provided by the HBAC was to maintain the existing one-way travel loop on Ocean Boulevard and Ashworth Avenue with two lanes on each roadway. Therefore, the recommendations developed for Ashworth Avenue under the 2018 update focused on creating a complete streets environment that would formally integrate pedestrians and bicyclists into the transportation system.**

The recommended plan (see Figure 8) maintains the existing two-lanes of southbound travel while formalizing the shoulder on the east side of the roadway to provide a southbound bike lane. Sidewalks are provided on both sides of the street and are proposed to be accented with street trees or other plantings to provide a more inviting and comfortable experience for pedestrians.

Maintaining the one-way circulation pattern on Ocean Boulevard and Ashworth Avenue, presents the opportunity to **keep the intersection of these streets (with Duston and Dover Avenues) unsignalized** and to promote better free

flow movements, reducing delays that would be produced by traffic signal installation. The concept shows using a raised median and pavement striping to separate the one northbound travel lane from Route 1A and the one southbound to northbound travel lane from Ashworth Avenue so that vehicles stay in their dedicated lanes on Ocean Boulevard past Dover Avenue. The southbound lane on Ashworth Avenue remains under free flow. The enhanced median area better defines the travel way, showing a more direct path for vehicles destined for Ocean Boulevard that are exiting from the Duston Avenue, which will remain under stop control.

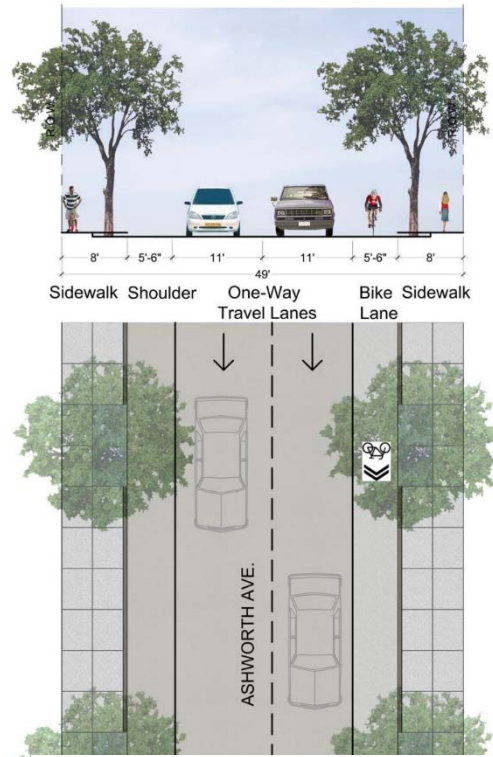

Recommended cross section for Ashworth Ave.

Similarly, **maintaining one-way travel southbound on Ashworth Avenue removes the need for traffic signal installation** at the intersections of Riverview Terrace/M Street, D Street, and Island Path as recommended in the 2001 plan. However, removing signalized intersections from the recommended plan for Ashworth Avenue requires further investigation into appropriate placement of crosswalks for pedestrians. As final design elements for this improvement progress, **formal study of pedestrian origins and destinations should be conducted to determine where pedestrian crossings should be installed to accommodate demands. Enhanced crossing areas with special pavement treatment, pavement markings, and signage should be considered to make the crossing locations more identifiable and attractive.**

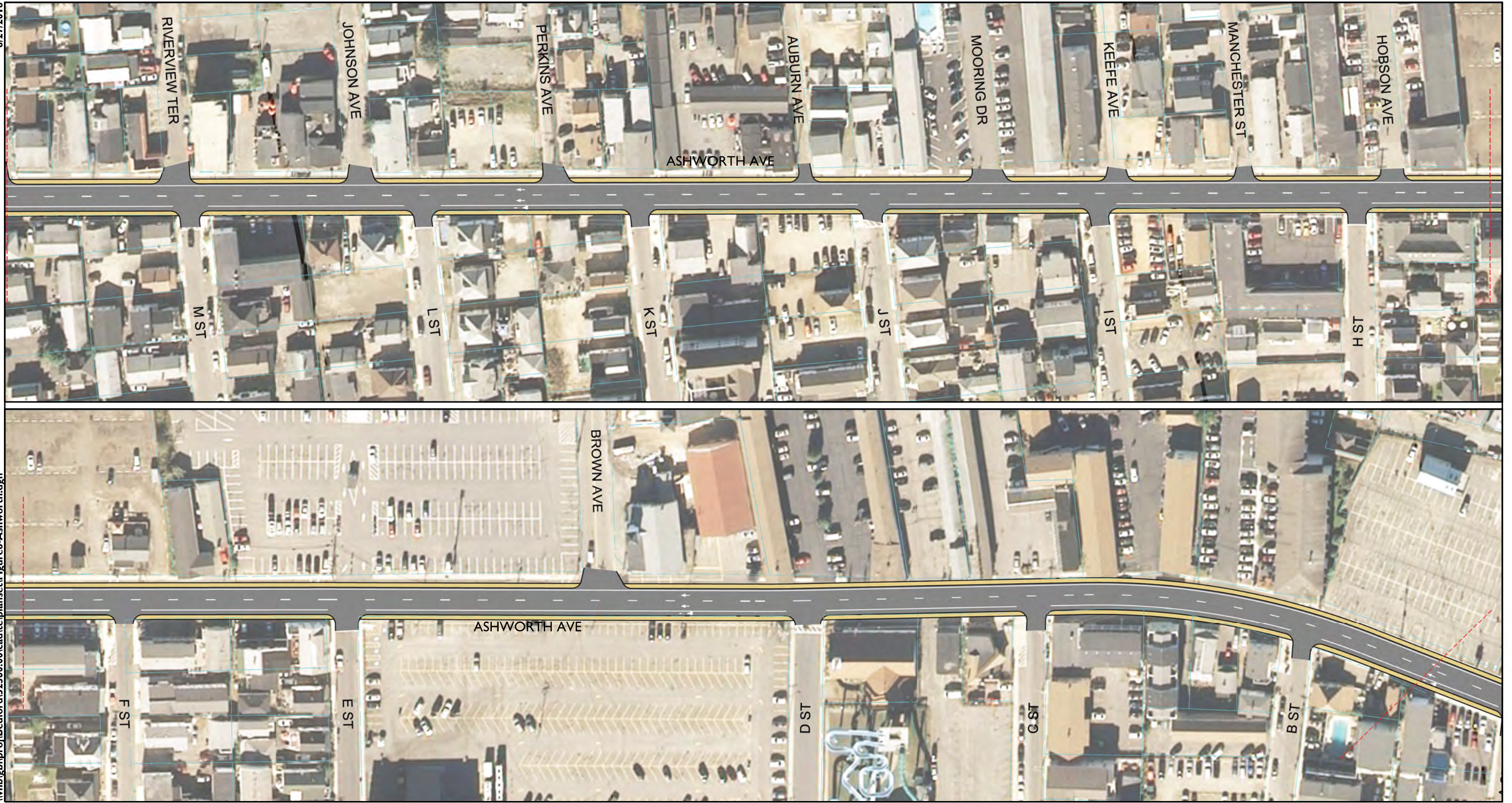

Figure 8 - Recommended Alternative for Ashworth Avenue B Street to M Street

Hampton Beach Transportation Master Plan Update
Town of Hampton, NH

Additional Engineering Design Considerations

When formal engineering design of the recommended plan is commenced, additional investigation will be required into a few areas, including the pedestrian crossings noted above. In addition, **the HBAC recommended that final design elements consider:**

- **Placing the crosswalks on the appropriate side of the intersections that minimize conflicts with vehicles turning into or out of the side streets**
 - **Crosswalk placed on the northside of the intersection when vehicles are exiting onto Ashworth Avenue**
 - **Crosswalk placed on the southside of the intersection when vehicles are turning onto side streets**
- **The placement of curbed bump-outs in concert with the crosswalks should be considered to reduce the overall length of the crosswalk while improving safety; however, appropriate placement and location should be vetted as to not slow traffic turning into side streets**
- **Softening radii on the corners of the side street intersections to make turning movements easier**
- **The placement and density of street trees for landscaping purposes**

Route 1A from Hampton Harbor Bridge to Dover Avenue

2018 Investigations and Recommendations

During the 2018 Master Plan update process, input from the public, the Hampton Beach Area Commission (HBAC) and various state and local stakeholders indicated that the 2001 recommended traffic circulation transformation on Ashworth Avenue and Ocean Boulevard was no longer desirable. **The HBAC was interested in investigating improvement opportunities that maintain the existing one-way travel loop on Ocean Boulevard and Ashworth Avenue with two lanes on each roadway.** This input was used to inform and develop the recommendations included in

this 2018 update for the segment of Route 1A from the bridge to the Ocean Boulevard/Ashworth Avenue intersection.

The 2018 update seeks to further evaluate the recommendations from the 2001 plan and to progress and conceptualize recommendations to move forward. The approach to developing concepts for this section of Route 1A sought to accomplish the desired safety and multimodal goals established in the original plan given the new direction noted above. Focal points of developing the concepts include opportunities to:

- Employ access management as a means of reducing conflict points and friction along Route 1A
- Install traffic control measures that will facilitate flow while managing turning movements and access to the side streets
- Implement a sidewalk on both sides of Route 1A with pedestrian crossings at both intersections
- Better accommodate bicycle traffic

Two concept plans were developed (see Figures 9 and 10). Both plans utilize access management strategies by relocating Harbor Road southerly, away from Duston Avenue. This relocation creates a new fourth leg to the intersection of Route 1A and State Park Drive and provides more direct and convenient access to the State Pier facility. Traffic control options for this four-way intersection include installation of a traffic signal with turning lanes on Route 1A for vehicles entering the side streets. Alternatively, a single lane roundabout could be considered to promote traffic calming and slower travel speeds at the four-way intersection, serving as a gateway to Ocean Boulevard. The roundabout option shifts the intersection southerly from the existing State Park Drive intersection location to better align with the entrance to the State Pier. Planning level analyses indicate that the roundabout would provide better operations than the signalized option; however, formal and more detailed analyses are required to confirm the operations and design details for each option.

Through this 2018 update process, the HBAC concluded not to support the roundabout at this location and would consider other intersection alternatives once the new Hampton Harbor bridge design and placement is determined.

The relocation of Harbor Road, combined with the direction from the HBAC to maintain the one-way circulation on Ocean Boulevard and Ashworth Avenue, presents the opportunity to keep the intersection of these streets unsignalized and to promote better free flow movements, reducing delays and congestion. The concept shows using a raised median and pavement striping to separate the one northbound travel lane from Route 1A and the one southbound to northbound travel lane from Ashworth Avenue so that vehicles stay in their dedicated lanes on Ocean Boulevard past Dover Avenue. The southbound lane on Ashworth

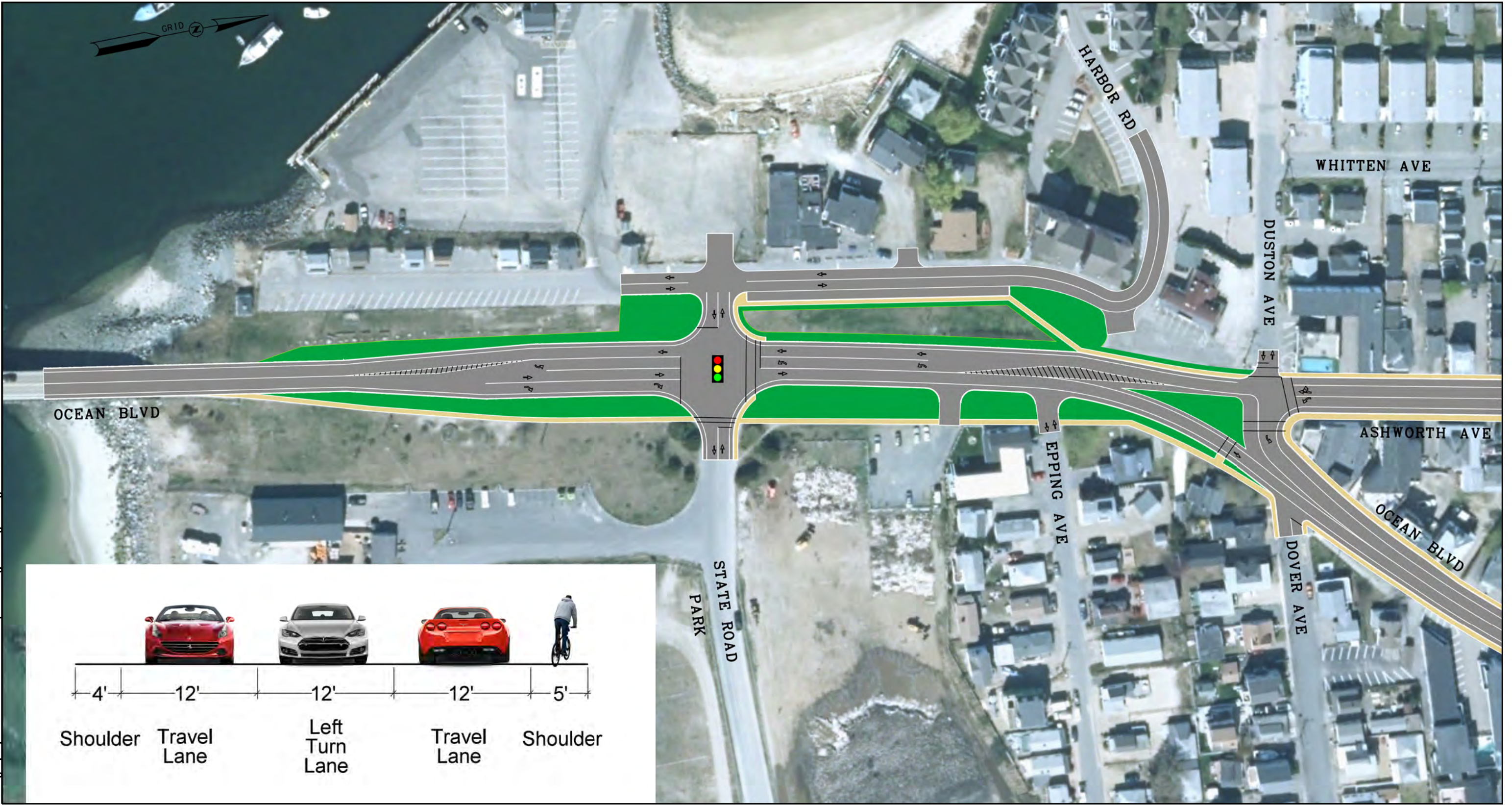

Figure 9 - Signalized Intersection Alternative Route 1A and State Park Drive

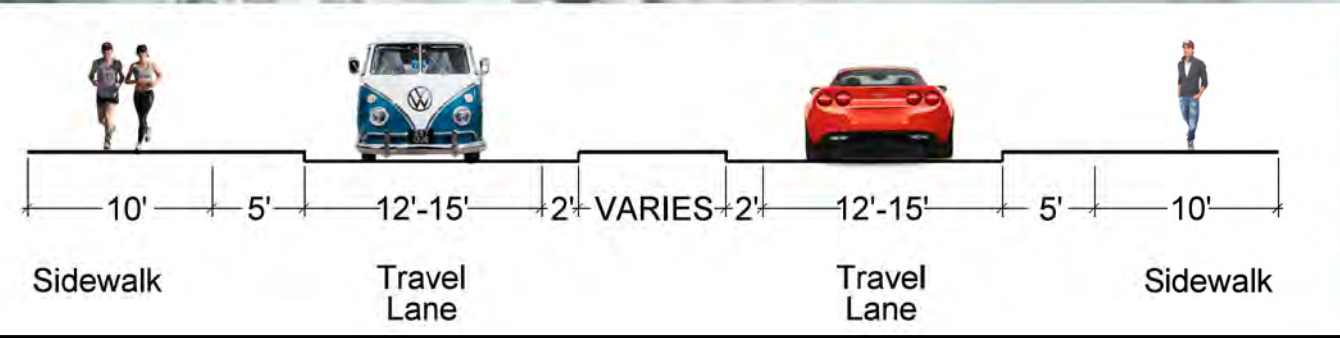
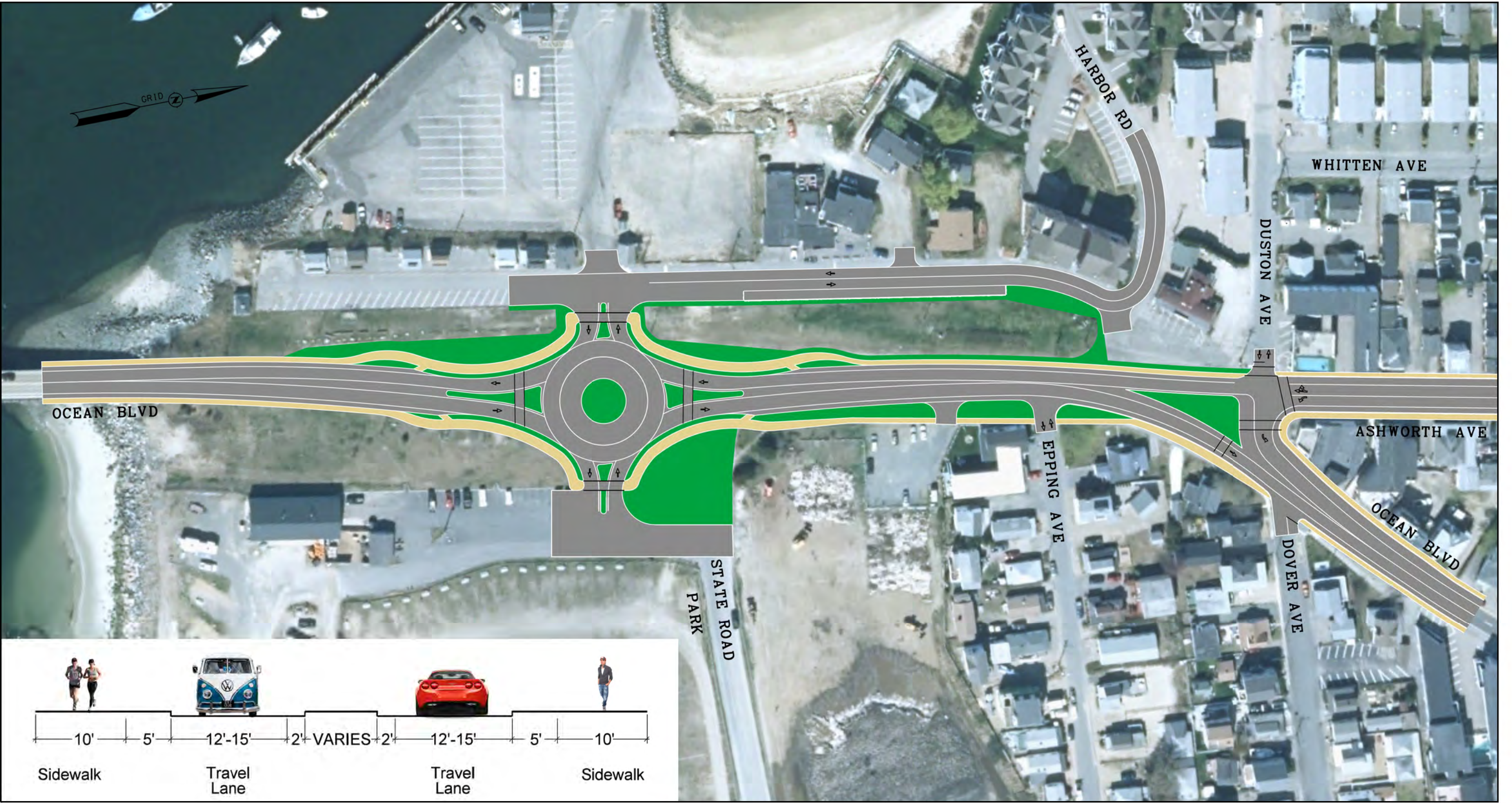

Figure 10 - Roundabout Alternative Route 1A and State Park Drive

Avenue remains under free flow. The enhanced median area better defines the travel way, showing a more direct path for vehicles destined for Ocean Boulevard that are exiting from the Duston Avenue, which will remain under stop control.

Finally, this option provides opportunities to improve access and safety near the Duston/Ocean/Harbor Road intersection. Specifically, the concepts reviewed corrected some of the access, parking and traffic circulation concerns near the restaurant on the corner of this intersection.

Additional Engineering Design Considerations

While these concepts show some promise at addressing existing traffic operations issues, there are additional concerns that could not be addressed as part of the plan update efforts – but will require additional investigation as engineering design progresses. These concerns include:

- **Improving state park access options such as:**
 - **More lanes and ticket booths entering the State Park to facilitate better flow into the site and reduce delays that result in vehicles stacking out onto Route 1A**
 - **Providing a separate right-turn lane for vehicles entering the State Park**
- Ensuring that the roundabout option can accommodate trucks and vehicles pulling boat trailers
- Examining if the relocation of Harbor Road requires on-site circulation changes for the operations of the State Pier and other business activities
- Examining Harbor Road access options from Duston Avenue
- Widening the Hampton Harbor Bridge and this segment of Route 1A to accommodate two travel lanes in each direction
- Coordinating proposed changes to this segment with the planned Hampton River Bridge replacement plans

As mentioned previously, the intent of this 2018 update is to further evaluate and refine the strategies outlined in the 2001 Master Plan. The analysis and plans developed at this stage are conceptual in nature. Further data collection, analysis, documentation, engineering design, and permitting will be required to bring the concepts to implementation. As funding becomes available to move portions of the plan into official projects, the comments and input from the stakeholders will be taken into consideration, addressed, and used to modify the plans accordingly.

Ocean Boulevard from Dover Avenue to Haverhill Avenue

2018 Investigations and Recommendations

During the 2018 Master Plan update, the 2001 recommended reduction of Ocean Boulevard to a single travel lane was further vetted for feasibility and presented to the HBAC and the public. This evaluation considered various scenarios of how a bicycle lane, wider sidewalks, parking and flex space for delivery vehicles could be incorporated into the plan if Ocean Boulevard were reduced to one-lane of travel northbound. While many of these concepts show great potential of meeting the goals of the 2001 plan, input from the public, the Hampton Beach Area Commission (HBAC) and various state and local stakeholders indicated that this change in circulation was no longer desirable. **The HBAC was interested in investigating improvement opportunities that maintain the existing one-way travel loop on Ocean Boulevard and Ashworth Avenue with two lanes on each roadway.** Therefore, the 2018 recommendations developed for Ocean Boulevard focused on balancing the desired goals of the Master Plan and the 2018 update (such as enhanced mobility and safety for pedestrians and bicyclists) within the constraints created by retaining two lanes of travel on Ocean Boulevard.

The recommended plan (see Figure 11) maintains the existing two-lanes of northbound travel, a five-foot shoulder on the east side of the roadway to accommodate bicycle traffic, a widened variable width shoulder on the west side to accommodate delivery vehicles, and formal variable width sidewalks on both sides. The inclusion of formal, curbed sidewalks will vastly improve safety along this segment of Ocean Boulevard, as well as the character of the roadway as it transitions into the beach area. As final engineering plans are developed, the recommendation is to focus on providing wider sidewalks as the roadway progresses northerly to better accommodate the increased volume of pedestrian travel to/from the beach.

Additional Engineering Design Considerations

When the next phase of work begins, formal ground survey will help to better inform the existing right-of-way along Ocean Boulevard, allowing better definition of how wide the sidewalk on the east side can be extended. **Providing enhanced pedestrian connectivity and improved mobility to/from the beach and parking lot area should be a priority, including consideration for a new entrance to the beach area. In addition, the HBAC recommended that wider sidewalks should take priority over on-street residential parking in this area. It was the consensus of the Commission that residential properties**



Figure 11 - Recommended Two-Lane Northbound Alternative for Ocean Boulevard Dover Avenue to Haverhill Avenue
Hampton Beach Transportation Master Plan Update
 Town of Hampton, NH

abutting Ocean Boulevard along this segment should accommodate their own parking. Consideration for limited parallel parking should be evaluated in balancing all the needs of this section.

Ocean Boulevard from Haverhill Avenue to Ashworth Avenue

2018 Investigations and Recommendations

During the 2018 Master Plan update, the 2001 recommended reduction of Ocean Boulevard to a single travel lane was further vetted for feasibility and presented to the HBAC and the public. This evaluation considered various scenarios of how a bicycle lane, wider sidewalks, parking and flex space for delivery vehicles could be incorporated into the plan if Ocean Boulevard were reduced to one-lane of travel northbound. **While many of these concepts show great potential of meeting the goals of the 2001 plan, input from the public, the Hampton Beach Area Commission (HBAC) and various state and local stakeholders indicated that this change in circulation was no longer desirable.** In particular the emergency responders expressed concerns with regard to response time and space for their equipment under the 2001 plan with one travel lane northbound on Ocean Boulevard and two-way traffic on Ashworth Avenue. Also noted, were concerns related to flooding and the impacts the reconfigured 2001 plan would have on Ashworth Avenue.

Alternatively, the HBAC was interested in investigating improvement opportunities that maintain the existing one-way travel loop on Ocean Boulevard and Ashworth Avenue with two lanes on each roadway.

Therefore, the 2018 recommendations developed for Ocean Boulevard focused on balancing the desired goals of the Master Plan and the 2018 update (such as enhanced mobility and safety for pedestrians and bicyclists) within the constraints created by retaining two lanes of travel on Ocean Boulevard.

The width on Ocean Boulevard is variable through this segment and widens heading north from Haverhill Avenue toward Ashworth Avenue. For the southern-most (narrowest) segment, the recommended plan calls for holding the existing sidewalk and on-street parking on the east side of the roadway, and then providing a five-foot shoulder (bicycle lane) and two northbound travel lanes (see Figures 12 and 13). The remaining roadway width, west of the travel lanes, would be designated for shoulder width (flex zone for delivery/loading purposes) and sidewalk. The amount of width allocated for shoulder and sidewalk space will need to be determined through the final design phase when physical ground survey is conducted to confirm the existing right-of-way.



Figure 12 - Recommended Two-Lane Northbound Alternative for Ocean Boulevard Haverhill Avenue to H Street

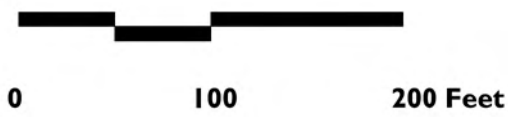

Figure 13 - Recommended Two-Lane Northbound Alternative for Ocean Boulevard H Street to B Street

Hampton Beach Transportation Master Plan Update
Town of Hampton, NH

As mentioned above, Ocean Boulevard widens traveling northbound, providing additional flexibility and options for sidewalk and shoulder widths, as well as bicycle lane design. Bicycle lane options presented to the HBAC include a five-foot shoulder, a formal five-foot bicycle lane with a three-foot buffer to the on-street parking, and a sixteen-foot wide northbound travel lane that allows bicyclists to share the road. These design options will be further vetted during the final design phase.

On and off-street parking facilities for this segment of Ocean Boulevard are anticipated to be generally unaffected by the plan options.

Additional Engineering Design Considerations

The recommended alternative determined through this 2018 update was selected for further evaluation in the next phase of work as it accomplishes many of the goals and objectives of the original 2001 plan with regard to improving mobility and safety for pedestrians and bicyclists, but also takes into consideration current existing conditions, data, and demands placed on the system, as well as concerns from stakeholders and emergency responders. When the next phase of work begins, formal ground survey will help to better inform the existing right-of-way along Ocean Boulevard, allowing formal decisions to be made regarding sidewalk, shoulder and bicycle lane widths. The HBAC recommended the following additional considerations for the final design phase:

- Implement formalized movable barricades to promote safer and more controlled pedestrian traffic flows
- Potentially eliminate the “middle” sidewalk south of the playground
- Preserve the existing parking supply in this core area
- Locate the bicycle lane on the east side of the traffic to minimize potential pedestrian conflicts
- Evaluate opportunities to reduce bicycle conflicts with vehicles parking along Ocean Boulevard

Ocean Boulevard from Ashworth Avenue to Great Boars Head Avenue

2018 Investigations and Recommendations

The 2018 update examined both the Highland Avenue and Church Street intersections as in the 2001 plan, but also explored opportunities to improve the overall corridor regarding multi-modal mobility and safety. Three options were evaluated for this segment of Ocean Boulevard. Each option considered reducing the existing four-lane roadway (with center median parking) to provide a three-lane section consisting of a single travel lane in each direction and a center turn lane. Most notably, the three options considered relocating

some or all the center median parking to the east side of the roadway to improve pedestrian safety, as well as potential changes in circulation for providing additional egress from the beach. In addition, Ocean Boulevard intersection improvements considered as part of this alternative included:

- Ashworth Avenue (north) – use of raised medians to reduce the openness of the intersection, better delineate the travel way, and narrow pedestrian crossings such that only one lane of travel will be crossed at a time.
- Highland Avenue – installation of a roundabout and reconfiguration of Highland Avenue to accommodate two-way traffic, or installation of a traffic signal while maintaining one-way travel eastbound on Highland Avenue.
- Church Street – installation of a traditional “T” signalized intersection with an exclusive pedestrian phase or a signalized jug handle intersection that would accommodate a concurrent pedestrian crossing on Ocean Boulevard. **The HBAC voted to not support the jug handle intersection alternative.**

Upon presenting these concepts to the public and receiving feedback that the residents prefer to keep the parking in the center of the roadway in order to protect the view shed of the ocean, the HBAC chose to modify the existing condition by:

- **Leaving the parking in the center of the roadway, but implement improvements that replace and raise the height on the guardrails such that pedestrians cannot step over them**
- **Exploring options that strategically minimize entrances and exits to the parking area**
- **Improving crosswalks and pedestrian walkways**

Additional Engineering Design Considerations

The 2018 plan recommended herein was selected for further evaluation in the next phase of work. However, the recommendations herein have not been conceptualized and therefore, additional data collection, analysis, and engineering design will be required to further detail the recommendations and determine project limits, impacts, and feasibility. Other considerations were identified by the HBAC for further evaluation during the formal design phase. The considerations include:

- Considering other alternatives for improvements at the Church Street and Highland Avenue intersections

- **Addressing safety and improving visibility at Highland Avenue**

Ocean Boulevard from Great Boars Head Avenue to Winnacunnet Road

2018 Investigations and Recommendations

During the preliminary stages of this update process, the HBAC requested that the study area be expanded to include the segment of Ocean Boulevard extending north to Winnacunnet Road. In March 2016 the expansion to the study area was approved and incorporated into the 2018 plan update. The goals and objections for this northern segment of Ocean Boulevard are consistent with those of the 2001 plan with emphasis on:

- Enhancing the pedestrian environment
- Accommodating bicycles
- Improving the location and supply of parking to better serve all users

In addition, the HBAC recommended that goals and objectives for this segment be expanded to specifically focus on addressing elevation and drainage deficiencies that exist in this area. Also, the HBAC recommended examining the opportunity to eliminate or reduce parallel parking along Ocean Boulevard.

Initial investigations of the expanded study area included mapping existing conditions such as sidewalks, bicycle and transit accommodations, parking inventories, and environmental resources. (More detail on the existing conditions of the expanded study area can be found in the Technical Memorandum prepared by VHB, dated May 19, 2016.) It is important to note that historical traffic volume data available from the NHDOT was compiled and reviewed; however, updated and detailed traffic volume data was not collected for the expanded study area (as was collected for the original study area).

Initial findings of the existing conditions

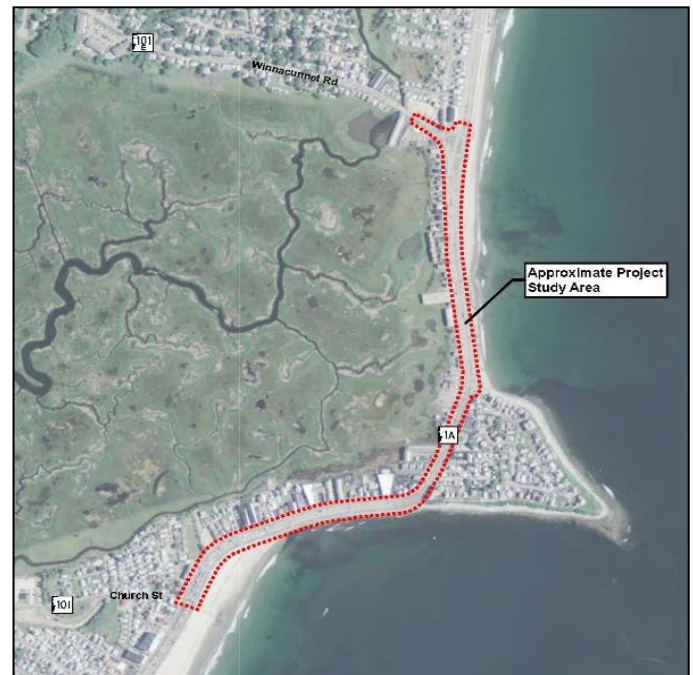

Expanded Study Area

investigation revealed numerous deficiencies, such as:

- **A lack of vertical delineation between the sidewalk and the shoulder, which is used for short term parking and/or delivery vehicles, along the western side of Ocean Boulevard;**
- **Sidewalk with utilities located within them along the western side of Ocean Boulevard;**
- **Only one of the existing pedestrian crossings on Ocean Boulevard (just north of Winnacunnet Road) provides ADA compliant pedestrian ramps and pedestrian warning signage;**
- **A lack of painted crosswalks on Ocean Boulevard; and**
- **A general lack of painted bike lanes, consistent shoulder widths, and/or share the road signage and striping (sharrows) throughout the expanded project study area.**

The 2018 update examined conceptual improvement plans and typical sections to address the future needs and deficiencies within the expanded project study area. This northern segment of Ocean Boulevard, unlike the southern segment that is heavily commercially based, presents the opportunity to promote an environment that is more multi-modal focused to enhance the beach experience for both residents and visitors. The following first summarizes the recommendation for the overall roadway segment, and then details the options and recommendations for the intersection of Winnacunnet Road. Recommendations for this segment are summarized in Figures 14 and 15.

Roadway Segment

The recommended plan seeks to reduce the Ocean Boulevard travel way from two lanes in each direction to a single lane northbound and southbound, and to eliminate the center parking that currently exists north of Dumas Avenue. This modification makes way for the installation of formal sidewalk on the west side of Ocean Boulevard and 6-foot bicycle lanes in each direction with an additional 2-foot offset (to protect from parked vehicles). The plan also calls for providing separate left-turn lanes on Ocean Boulevard at the intersections of Great Boars Head Avenue and Dumas Avenue. While the plan allows for parallel parking on both sides of the street, **the HBAC recommended eliminating parallel parking where possible.**



Figure 14 - Recommended Alternative for Ocean Boulevard-Great Boars Head Avenue Approaching Winnacunnet Road
Hampton Beach Transportation Master Plan Update
 Town of Hampton, NH



0 100 200 Feet



Figure 15 - Recommended Alternative for Ocean Boulevard at Winnacunnet Road

**Hampton Beach Transportation
Master Plan Update**
Town of Hampton, NH

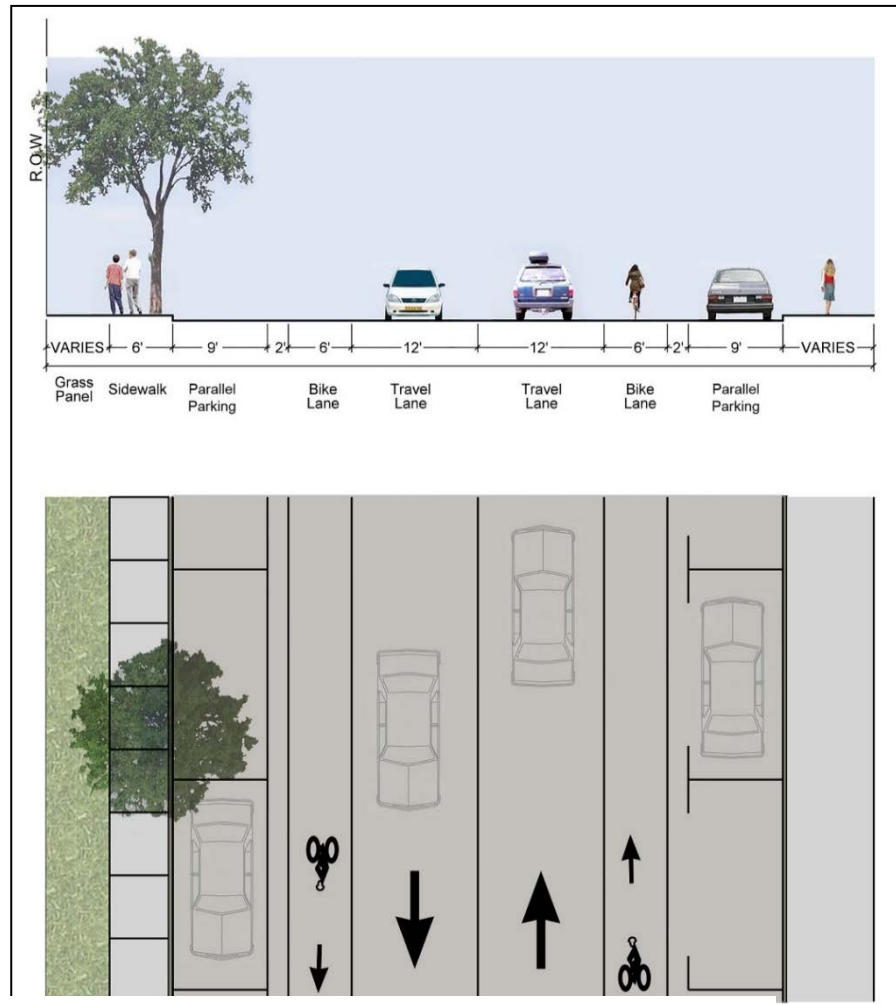

Typical Section for Ocean Boulevard North of Great Boars Head

Ocean Boulevard at Winnacunnet Road

Two options were evaluated for the intersection of Winnacunnet Road. The first option considered reconfiguring the intersection to accommodate a single lane roundabout. In order to meet the appropriate design criteria and operational needs of the intersection, the roundabout plan calls for closing off Kings Highway from the roundabout, creating a cul-de-sac. Alternatively, Kings Highway traffic would utilize alternative routes, such as 1st Street and 2nd Street, to gain access to and egress from Ocean Boulevard. The plan includes the construction of a 47-space off-street parking lot in the south east corner of the intersection. Under this option, it is estimated that the parking supply could increase by approximately 20 spaces from 136 to 156 spaces provided between on-street parking and the off-street parking facilities. This intersection option was not supported by the HBAC for further consideration because of the need to close off Kings Highway (the second option was preferred).

The second option, which is recommended, calls for reconfiguring the intersection to provide a traditional four-way intersection and installing a traffic signal. Under this concept, Ocean Boulevard provides a single through travel lane in each direction, plus a northbound left-turn lane and a southbound right-turn lane. Vehicles exiting from Winnacunnet Road would be accommodated with separate left-turn and right-turn lanes. This layout allows for a fourth leg to the intersection, providing egress from a small parking lot located in the south east corner. It is estimated that this alternative has the potential to increase the parking supply by 37 spaces (from 136 to 173 spaces) between on and off-street parking with 57 spaces in the off-street lot.

Additional Engineering Design Considerations

The recommendations herein are conceptual in nature and based on limited data and base information available at the time of this update. Therefore, additional data collection, analysis, and engineering design will be required to further detail the plans and determine project limits, impacts, and feasibility. Other considerations were identified by the HBAC for further evaluation during the formal design phase. The considerations include:

- **Maintaining connectivity to Kings Highway at Winnacunnet Road in proximity of the signalized intersection**
- **Addressing ADA deficiencies**
- **Considering placement of restroom facilities in the vicinity of the Winnacunnet intersection**
- **Improving physical access (stairs) to the beach**
- **Studying the elimination or reduction of parallel parking along Ocean Boulevard**
- **Evaluating a conceptual plan that provides a three lane section along Ocean Boulevard between Great Boars Head Avenue and Winnacunnet Road, providing a single travel lane in each direction and a center two-way left-turn lane.**

In addition, the HBAC recommended that, in the future, the limit of work for reconstruction should be extended northerly to the North Hampton town line, including modifications to address the flooding issues.

4

Construction Cost Estimates and Roadway Segment Prioritization

Construction cost estimates were prepared for the various segments within the limits of the Hampton Beach Master Plan update. The estimates are order of magnitude estimates based on very limited engineering and will be refined several times during preliminary and final design based on a topographic survey, design advancement and geotechnical engineering.

The conceptual quantities for the major construction items such as common excavation, select materials, pavement, curbing, sidewalks and drainage were calculated to use as the baseline for the construction cost estimate. The remainder of items such as lighting, traffic signals, landscaping, traffic control erosion control signage, construction engineering, etc. were estimated using a percentage of accumulated costs and anticipated needs. The unit costs were primarily established using the NHDOT's Average Weighted Unit Prices and include no escalation to the year of construction. It is anticipated that the actual unit prices will be higher than normal since the construction of these improvements will likely be required to be completed before and after the beach season.

It was assumed that full box reconstruction would be required for all roadways except for Ashworth Avenue which was assumed a pavement inlay typical section. The estimates do not include costs for preliminary design, final design, geotechnical engineering, utility relocation designs, right-of-way acquisitions, public outreach and project management.

The estimates were calculated in roadway segments as shown in Table 4.

Table 4 Construction Cost Estimates

Roadway Segment	Construction Cost (2018)
Route 1A at State Park - Signalized	\$2,400,000
Harbor Road Improvements	\$600,000
Route 1A at Ashworth Intersection	\$900,000
Ocean Boulevard - Ashworth Avenue to Haverhill Avenue	\$1,600,000
Ocean Boulevard - Haverhill Ave to F Street	\$2,000,000
Ocean Boulevard – F Street to C Street	\$700,000
Ocean Boulevard - C Street to A Street	\$900,000
Ocean Boulevard - Highland Ave Intersection	\$1,200,000
Ocean Boulevard - Highland Ave to Church Street	\$1,900,000
Ocean Boulevard - Church Street to Great Boars Head Avenue	\$4,100,000
Ashworth Avenue	\$400,000
Ocean Boulevard - Great Boars Head Avenue to Dumas Avenue	\$1,700,000
Ocean Boulevard - Dumas Avenue to Winnacunnet Road	\$2,400,000
Ocean Boulevard - Winnacunnet Road Intersection	\$1,900,000
Ocean Boulevard - Winnacunnet Road to High Street	\$5,900,000
TOTAL	\$28,600,000

The current construction funding allocated within the NHDOT’s 2019 – 2028 Ten-Year Plan is approximately \$6.56M for 2024 construction. Therefore, with this shortfall in funding, implementation of the recommendations included within the 2018 update will require a prioritization. The identification of priorities could be developed through a benefit-cost analysis considering the potential community benefit of each (such as traffic operations, safety, pedestrian amenities, bicycle amenities, roadway maintenance and operations, etc.). This type of analysis would require much more detailed information than currently available to effectively and fairly weigh the various roadway segments (or projects).

Therefore, the priorities presented herein are based on discussions that occurred throughout the development of the 2018 update and the perceived highest value at this time. The priorities are identified and discussed below.

Priority 1 – The Ocean Boulevard improvements from Epping Avenue to the north Ashworth Avenue intersection could be considered the highest priority. These segments

serve as the southernmost gateway to Hampton Beach and the proposed improvements will provide improved traffic operations, pedestrian and bicycle improvements.

Priority 2 – The improvements along Ocean Boulevard from the north Ashworth Avenue intersection through the Church Street intersection could be considered the second highest priority. This segment includes a major ingress location at the Highland Avenue intersection and a major egress intersection at Church Street. The proposed concepts would provide more consistency in the overall Ocean Boulevard corridor while improving traffic operations, pedestrian and bicycle safety while supporting beach and merchant activities.

Remaining Priorities – The remaining segments include:

- Ashworth Avenue
- Route 1A from the Hampton Harbor Bridge to Epping Avenue, including the intersection with the State Park
- Ocean Boulevard, Church Street Intersection to Great Boars Head Avenue
- Ocean Boulevard, Great Boars Head Avenue to Dumas Avenue
- Ocean Boulevard, Dumas Avenue to the Winnacunnet Road Intersection
- Ocean Boulevard, North of the Winnacunnet Road intersection to High Street

The first two priorities account for more than the available current funding. In general, it is anticipated that the priorities would progress from south to north to match the volume and density of vehicles, pedestrians, bicyclists, neighborhoods and overall development. However, should partial funding become available, spot improvements could be implemented at the Winnacunnet Road intersection or short corridor improvements could be implemented such as Ashworth Avenue or the completion of Ocean Boulevard from Church Street to the Great Boars Head Avenue.

The identification of priorities is a snapshot in time and there are many factors that could impact the priorities at the time funding becomes available. Therefore, when the NHDOT is about to begin preliminary and final design for the current funding, and any future funding identified through the Ten-Year Plan process, additional coordination with the HBAC is necessary to reaffirm the available funding is matching the current priorities.



www.vhb.com