

# New Hampshire Department of Transportation

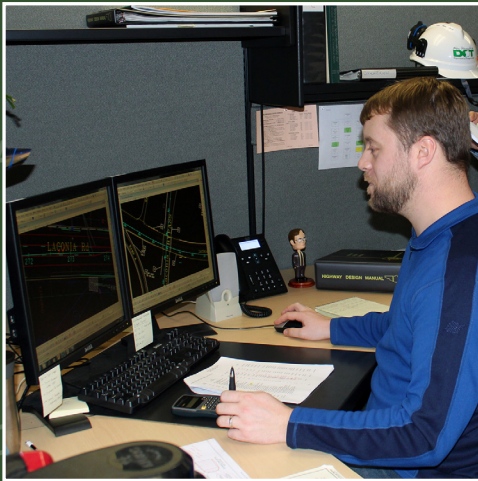

PROP. COMMON DRIVE  
PER PLAN L55-44

## 2017 CAD/D Procedures & Requirements

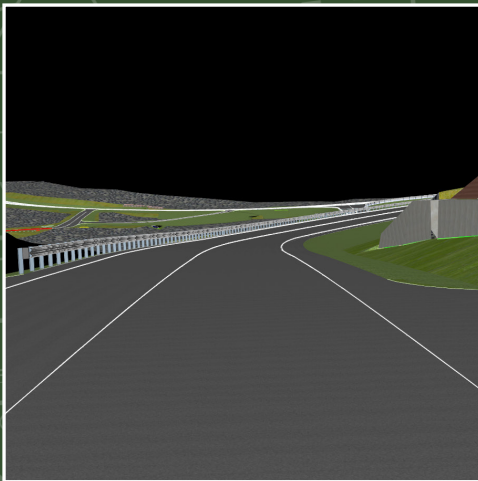

Effective June 1, 2017



|   |           |
|---|-----------|
| <b>PART I – GENERAL INTRODUCTION.....</b>           | <b>1</b>  |
| Disclaimer.....                                     | 1         |
| About the Cover.....                                | 1         |
| Revision Summary.....                               | 2         |
| June 2017.....                                      | 2         |
| April 2012.....                                     | 2         |
| Introduction.....                                   | 4         |
| Current NHDOT Software Versions.....                | 5         |
| Major Software and Current Production Versions..... | 5         |
| Future Upgrades.....                                | 5         |
| <b>PART II – GENERAL CAD/D INFORMATION .....</b>    | <b>7</b>  |
| Documentation.....                                  | 7         |
| Survey Datum.....                                   | 7         |
| Project Journal Files.....                          | 7         |
| Project Journal Guidelines.....                     | 7         |
| Sample CAD/D Project Journal.....                   | 8         |
| Directory Structure.....                            | 13        |
| <b>PART III – MICROSTATION.....</b>                 | <b>15</b> |
| MicroStation Workspace.....                         | 15        |
| File Naming.....                                    | 15        |
| Level Assignments and Symbology.....                | 15        |
| Reference File Attachments.....                     | 16        |
| Seed Files.....                                     | 16        |
| Imperial Seed Files (2D & 3D).....                  | 17        |
| Fonts.....  | 18        |
| Text Height and Spacing.....                        | 19        |
| Text Styles.....                                    | 19        |
| Linestyles.....                                     | 20        |
| NHDOT Custom Linestyle Resource Files.....          | 20        |
| True Size Linestyles.....                           | 20        |
| Scaled Linestyles.....                              | 21        |

|  |           |
|--|-----------|
| Custom Linestyle Scaling Charts .....              | 21        |
| Linestyles Created at 1:1 .....                    | 22        |
| <b>Color Table.....</b>                            | <b>22</b> |
| <b>Cross Hatching.....</b>                         | <b>22</b> |
| <b>Cell Files .....</b>                            | <b>24</b> |
| <b>Dimensioning.....</b>                           | <b>25</b> |
| <b>Plotting.....</b>                               | <b>25</b> |
| <b>Print Organizer.....</b>                        | <b>25</b> |
| <b>Pen Tables .....</b>                            | <b>26</b> |
| <b>PART IV – OPENROADS .....</b>                   | <b>27</b> |
| <b>Introduction .....</b>                          | <b>27</b> |
| <b>File Naming .....</b>                           | <b>27</b> |
| <b>Seed Files .....</b>                            | <b>27</b> |
| <b>OpenRoads Drawing Names .....</b>               | <b>27</b> |
| <b>Template Files.....</b>                         | <b>27</b> |
| <b>OpenRoads Cell Files &amp; Linestyles .....</b> | <b>28</b> |
| <b>Civil Cells .....</b>                           | <b>28</b> |
| <b>MX-Specific Notes .....</b>                     | <b>28</b> |
| MX File Naming.....                                | 28        |
| MX Model Naming .....                              | 29        |
| MX String Labeling.....                            | 29        |
| MX Style Sets.....                                 | 29        |
| MX Feature Sets .....                              | 29        |
| Cross-Section Settings Files .....                 | 29        |
| Add-Ins .....                                      | 30        |
| <b>PART V – PROCEDURES.....</b>                    | <b>31</b> |
| <b>Introduction .....</b>                          | <b>31</b> |
| <b>Exchanging Right-of-Way Data .....</b>          | <b>31</b> |
| <b>Legacy Alignments .....</b>                     | <b>32</b> |
| <b>Using OpenRoads Templates.....</b>              | <b>32</b> |
| <b>Roll Plans.....</b>                             | <b>32</b> |

---

|   |           |
|---|-----------|
| Cut Sheets.....   | 33        |
| Cross-Section Drawings .....  | 33        |
| Bridge Detail Sheets.....   | 33        |
| <b>PART VI – OTHER PROJECT DATA.....</b>                                | <b>35</b> |
| Drawing Quality Assurance / Quality Control.....                        | 35        |
| <b>PART VII - ENGINEERING CONSULTANT DELIVERABLE REQUIREMENTS .....</b> | <b>37</b> |
| Overview.....   | 37        |
| <b>File Format And Delivery .....</b>                                   | <b>37</b> |
| Requirements For Submitting Electronic Data To NHDOT .....              | 37        |
| Data Submission .....   | 38        |
| Intermediate Submissions .....  | 38        |
| Deviation From Format.....  | 38        |
| MicroStation Only Deliverable.....                                      | 39        |
| Record of Design as Submitted (Final Design Consultants Only).....      | 39        |
| File Conversion .....   | 39        |
| <b>Initiating a Design Project .....</b>                                | <b>40</b> |
| <b>Interim Project Deliverables.....</b>                                | <b>40</b> |
| <b>Project Completion.....</b>  | <b>41</b> |
| CAD/D File Information .....  | 41        |
| Projects Designed using InRoads.....                                    | 44        |
| Specialized Development by Design Consultants .....                     | 45        |
| <b>NHDOT Resources Available for Consultants.....</b>                   | <b>45</b> |
| <b>PART VIII - APPENDIX.....</b>  | <b>47</b> |
| <b>Appendix A - MicroStation Drawing Names.....</b>                     | <b>47</b> |
| <b>Appendix B - Level Mapping Convention .....</b>                      | <b>47</b> |
| <b>Appendix C - NHDOT Custom Linestyles &amp; Font .....</b>            | <b>49</b> |
| <b>Appendix D – MX Model Naming Convention .....</b>                    | <b>53</b> |
| <b>Appendix E – Civil Data Transfer Formats .....</b>                   | <b>53</b> |
| LandXML.....  | 53        |
| <b>Appendix F – Construction Reports .....</b>                          | <b>55</b> |
| Sample OpenRoads Alignment Report (COGO Style) .....                    | 55        |
| Sample OpenRoads Alignment Report (Coordinates) .....                   | 56        |
| <b>Appendix G – Cross Section Set Labels.....</b>                       | <b>57</b> |



# PART I – GENERAL INTRODUCTION

## DISCLAIMER

The procedures described in this document are for reference only. This information is provided on an "as is" basis. The material contained is provided without warranty or liability of any kind to the New Hampshire Department of Transportation (NHDOT).

Updating this manual is intended to be a continuous process. As technology evolves, policies change, and process improvements are discovered, this document will be updated to reflect those changes.

As with any documentation, improvements can and should be made. Any additions, suggestions or comments for improvement are encouraged. This documentation is not meant to be a complete instructional document. The intent is to provide guidelines that, if followed, will result in better quality and consistency for electronic plans and documents.

This manual, in its entirety, may be freely copied and distributed for the purpose of providing a consistent guide to the Computer Aided Design & Drafting (CAD/D) requirements of the New Hampshire Department of Transportation. Copies of this manual along with CAD/D resource files (style libraries, naming conventions, etc.) can be downloaded at <https://www.nh.gov/dot/cadd/downloads/index.htm>.

Any recommendations for improvements to this documentation are welcome. Any errors found should be brought to the attention of the CAD/D Staff so corrections can be made. For additional information or detailed explanations of the standards described within this document, contact:

CAD/D Support and Development  
Bureau of Highway Design  
New Hampshire Department of Transportation  
PO Box 483  
Concord, NH 03302-0483

NHDOT CAD/D Website: <https://www.nh.gov/dot/cadd/>  
E-mail: DOT-Cadd@dot.nh.gov  
Tel: 603-271-2171

## ABOUT THE COVER

With the transition to OpenRoads, it is now easier to work with 3D design models. This data can be used to produce 3D renderings of the design and provided to construction crews to set out control points, compute volume quantities and for guiding automated construction equipment. This year's cover depicts the process of developing the 3D model by the Bureau of Highway Design, reviewing the 3D rendering and using that data in Construction.

Photos courtesy of the Bureau of Highway Design and Bureau of Construction. 3D visualization by Highway Design's Joshua Lafond. Cover design by LJ Place of the CAD/D Section.

## REVISION SUMMARY

### JUNE 2017

#### Part I– General Introduction

- Updated software versions.

#### Part II– General CAD/D Information

- Revisions to Project Journal File to reflect transition from MX design to OpenRoads.
- Updates to project directory structure.

#### Part III– MicroStation

- Seed file information changed to reflect transition towards US Survey Foot files plus additional information of Geographic Coordinate Systems.
- Information about the NHDOT pen table has been updated.

#### Part IV– OpenRoads

- Section renamed from Part IV - MX.
- Rewrite to section to reflect transition from MX design to OpenRoads.

#### Part VII - Engineering Consultant Deliverable Requirements

- Section significantly modified to update for transition to OpenRoads design.
- Included information about Item 670.822 - GNSS Construction Inspection Equipment

#### Appendix

- Linstyle charts in Appendix C have been updated.
- *Appendix D – MX Model Naming Convention* has been removed.

### APRIL 2012

#### Part I– General Introduction

- New software versions.

#### Part II– General CAD/D Information

- The project directory structure was modified to separate MX data from contract plan drawing data.

#### Part III– MicroStation

- Updates to cell file listing.
- Seed file information now includes geographic coordinate system being used.
- Information about the NHDOT pen table has been updated.

#### Part V – Procedures

- The process for creating cut sheets has been modified along with the sheet naming convention.



**Part VI – Other Project Data**

- Notes on QA\_Input and other GDM programs have been replaced by descriptions of task menus.

**Appendix**

- Changes to MicroStation drawing names in Appendix A.
- Linestyle charts have been updated in Appendix C.
- Appendix D (MX model names) has been updated to reflect current practices.
- MX String label lists have been updated.

## INTRODUCTION

This document contains the New Hampshire Department of Transportation's (NHDOT) specifications for electronic (computer) data as it relates to engineering design projects. It explains the minimum requirements that must be met for all Computer Aided Design & Drafting (CAD/D) data produced by and for the New Hampshire Department of Transportation. This is to ensure that CAD/D files can be used by the entire project team throughout all phases of project development. While the requirements contained herein provide a basis for uniform CAD/D practice for NHDOT projects, precise rules that would apply to all possible situations that may arise are not possible to describe. Situations may exist where these standards will not apply. If variances from the "CAD/D PROCEDURES AND REQUIREMENTS" are necessary for a project, they must be approved in writing by the NHDOT Project Manager and documented in the Project Journal File as defined herein. The creation of MicroStation drawings and/or levels for features that are not described in this document shall be documented in the Project Journal File. The creation of MX models that are not described in this document shall be documented in the Project Journal File.

As a minimum, NHDOT Design staff and engineering consultants are expected to adhere to the standards that were in force at the time the contract was initiated. Although not required, following the latest standard is recommended whenever feasible.

In addition to the traditional hardcopy delivery items, NHDOT requires supplementary electronic data delivery items. This data shall be submitted in the formats specified in *Part VII - Engineering Consultant Deliverable Requirements*. In general, design data and Digital Terrain Model (DTM) data is to be provided in the OpenRoads DGN or LandXML formats, and graphical data is to be provided in MicroStation's .DGN drawing format. Organizations wishing to perform professional engineering services for NHDOT are required to deliver electronic data as specified by this document. This specification also requires organizations to accept and utilize pertinent electronic input data as provided by NHDOT.

These electronic delivery items **DO NOT** replace any **hardcopy** delivery items.

This document is published as an update to the "CAD/D PROCEDURES AND REQUIREMENTS" document dated April 2012 and supersedes all CAD/D standards previously published. Sections which have changed from the previous version are denoted by the vertical line in the right margin.

### Trademarks

**Microsoft** and **Windows** are registered trademarks of Microsoft Corporation.

**MicroStation**, **OpenRoads**, **MDL**, **InRoads**, **GEOPAK**, **MX**, and **MXROAD** are registered trademarks of Bentley Systems, Inc.

## CURRENT NHDOT SOFTWARE VERSIONS

NHDOT desires to stay current with state of the art trends in the market, however, budget constraints, statewide implementation, impact on users, and providing support for the new features must be considered prior to any change.

As NHDOT makes a change that results in modifying electronic procedures, the "CAD/D PROCEDURES AND REQUIREMENTS" will be updated where necessary to reflect the change. A list of the modifications will be found in the revision summary. **As a rule, until documentation is modified, deviation from the current dated requirements must be approved by the Project Manager.**

### MAJOR SOFTWARE AND CURRENT PRODUCTION VERSIONS

1. MicroStation V8i (SELECTseries 4) (version 08.11.09.832)
2. MX V8i (SELECTseries 4) (version 08.11.09.878)
3. Microsoft Office 2010 products with Access 2003

### FUTURE UPGRADES

A newer version of MicroStation (the CONNECT Edition) is presently available and will be tested in the future to determine when or if NHDOT will upgrade to that version.

OpenRoads Designer, Bentley's replacement for the civil design products – MX, InRoads and Geopak – will be tested and eventually replace MX.



## PART II – GENERAL CAD/D INFORMATION

### DOCUMENTATION

Documentation of NHDOT CAD/D practices and procedures can be found on the Internet at <https://www.nh.gov/dot/cadd/>. Summaries of selected procedures will be found in *PART V – PROCEDURES* beginning on page 31.

### SURVEY DATUM

For NHDOT projects, the horizontal and vertical coordinate systems can vary from project to project depending on a variety of conditions. New projects will tend to have a vertical datum based on NAVD88 with the horizontal coordinates using NAD83/2011F. However, the designer should always check with the Survey group to confirm these details so the CAD/D drawings can be set up correctly.

### PROJECT JOURNAL FILES

#### PROJECT JOURNAL GUIDELINES

A Project Journal will be produced for each project. On consultant-designed projects, a copy of the journal file will be delivered with each electronic project plan submission. The purpose for this journal is to aid downstream customers of the CAD/D data so they may utilize existing CAD/D work in their processes. The format of the journal will be an electronic file, either in text format or a format supported by Microsoft Word 2010. As a minimum, the journal will contain the following information:

- A listing (Index) of the project files, including brief descriptions of each file and where the file is located.
- Documentation about the CAD/D software used, special CAD/D decisions made, exceptions to standards that were made, problems encountered and how they were addressed or other important issues that arose during the course of the CAD/D work. For example, if a custom linestyle needed to be created, the justification, resource file, and files where that linestyle was used would be documented in the Journal. Other documentation would include the design software used (including version number), particular software settings, and other information that would help a downstream user of the data understand how it was created.

Important data that should also be contained in the Journal include:

- All information necessary for the regeneration or use of those files by subsequent customers of the CAD/D data

- Document the design data, controlling alignment and profile names and geometry input/output files, relevant survey information, cross sections and the methodology used to obtain the final geometric controls in the CAD/D product.

NHDOT has not established a specific format for the Journal file. The sample file shown on the following pages should be used as a guideline for the type of information to be included and format that is expected.

The project journal must be kept up to date as the CAD/D design work progresses and be delivered with the project on the preferred media for archival purposes.

#### SAMPLE CAD/D PROJECT JOURNAL

## CAD/D PROJECT JOURNAL

(12345\_project\_journal.doc)

5-7-2017

### PROJECT JOURNAL

This file contains information about the project **12345** and the corresponding electronic files contained in the **project directory**. This file should be kept up to date and stored in the project's "cadd" directory. If a project is archived, this file is to be included with the project's electronic files. When filling in the required information, please delete the instructions and examples in order to maintain a concise record.

### PROJECT DESCRIPTION

**State Project Number:** ..... 12345  
**Federal Aid Number:**..... N/A  
**County:** ..... County  
**Project Manager:** ..... Project Manager  
**Project Designer:**..... Project Designer  
**Project Directory:** ..... N:\cadd\pbt\xx\12345\cadd\prj  
  
**Project Units:**.....Imperial-USSF  
  
**Project Scale:**.....50 20  
  
**Survey Field Book #'s:**...#,#,#

### SCOPE OF WORK

Include as much detail as necessary to define the work done for the project.

## PROJECT FILES

List any drawing files that do not fit into the standard naming convention. Include a brief description of the data contained in each one.

## MICROSTATION FILE INFORMATION

**Seed File(s) Used for this Project:** nhseedf2-ussf.dgn nhseedft-ussf.dgn nhseed-or-ussf.dgn

### Non-Standard Drawings

List any drawings that are not on the standard naming convention list with a brief description of each one's contents.

### Plot Information

List information about Print Organizer specifications, pen tables, or other features used to generate the plot files.

## OPENROADS

Template File name – 12345NHDOT-IMP.itl  
Project XIN file if not standard -  
Project Features DGNLIB if used –  
Project Civil Cell DGNLIB if Used -

### Roadway – "Road Name"

#### *Alignment Information*

DGN Name .....12345-Geometry.dgn  
  
Horiz. Alignment Feature Name..MCxM Rte 16  
Vert. Alignment Feature Name....MCxM Rte 16 Prof  
Existing Feature Name       MCxM Sect Exist Elev  
Associated MX Model .....GEOMETRY  
Associated MX String.....MCxM  
Old Ground Profile String.....OCxM

#### *Reports*

Horizontal Review ASCII- ....12345-MCxM-Hor-Review.txt  
Horiz. Interval Points XYZ....12345-MCxM-Hor-XYZ.xls  
Vertical Review ASCII.....12345-MCxM-Vert-Review.txt  
LandXML .....12345-MCxM-Landxml.xml (saved as a Text file named xml)

#### *Corridor Information*

DGN Name .....12345-Corridor  
Corridor Name .....MCxM   Rte 16 Cor

SuperElevation XLS file name MCxM-ss4\_superelevations\_2\_4.xlsm  
 Parametric Constraint txt file for import -  
 Guardrail Design XLS file name MCxM\_guardrail\_calcs\_office\_2010.xlsx  
 Parametric Constraints txt file for import -  
 Corridor Exported Parametric Constraints  
 Corridor Exported Template Drops CSV

***Drive Information***

DGN Name  
 Drive list containing:  
 Drive Station \ Horizontal Geometry Name \ Vertical Geometry Name \ Civil Cell

***Section Information***

DGN Name .....12345-xsections  
 Custom Settings .XSC .....12345-MCxM-Sta-Sta.xsc  
 XS Model Name .....MCxM Sta to Sta  
 XS Detail dgn name .....12345-Xs-Detail-MCxM  
 XS Detail Data File

**MX FILE INFORMATION**

Preliminary Design Engineer: Your Name

Final Design Team Leader: Team Leader

**General MX (Plan Prep) Information**

Existing Traverse Model.....TRAV  
 Existing Detail Model.....TOPO  
 Existing Triangulation Model TRIANGLES  
 String.....TX00  
 Existing Contour Model.....CONTOURS  
 Strings .....Major - D  
 .....Minor - 0

| <b><u>MX Design Input File Names</u></b> | <b><u>Description</u></b>   |
|--|---|
| Topo.inp                                 | A compilation of processed survey data recorder files that creates TOPO model.                      |
| Triangles.inp                            | Creates TRIANGLES and CONTOURS models by triangulating TOPO model.                                  |
| PPalign.inp                              | Creates PPALIGN model and includes “geometry” to create each Plan Prep alignment.                   |
| PPprofiles.inp                           | Creates existing ground profile (“O”) strings for each Plan Prep alignment, which are stored in the |



|                   |   |
|-------------------|---|
|                   | PPALIGN model.  |
| PPsections.inp    | Creates cross sections for each Plan Prep alignment, which are then stored in their own model (ex. PPSECTMC1S).   |
| Topo-features.inp | Creates TOPO FEATURES, TOPO UTILITY, and TOPO STRUCTURE models and copies various strings from the TOPO model into each. Used for creating OpenRoads terrain models and features. |
| Topo-features.prn | Output of input file above.   |
|                   |   |
|                   |   |
|                   |   |
|                   |   |

| <b><u>MX Design Output File Names</u></b> | <b><u>Description</u></b>   |
|---|---|
| Topo.prn                                  | Output from Topo.inp – Reports assigned string labels and errors. Contains X, Y, Z coordinates of the survey points.          |
| Triangles.prn                             | Output from Triangles.inp – Reports crossing strings, minimum and maximum elevations and plan area.                           |
| PPprofiles.prn                            | Output from PPprofiles.inp – Reports x,y,z coordinates of each Plan Prep alignment.   |
| PPsections.prn                            | Output from PPsections.inp – Reports string assignments as well as point and offset information for each Plan Prep alignment. |
|   |   |
|   |   |
|   |   |
|   |   |
|   |   |

**TEXT FILES**

Include information about output files, genio files, or other ASCII files provided with the project drawings.

**SPECIAL INFORMATION/COMMENTS**

**Master Alignment – "Road Name"**

**Alignment Information**

Plan Prep Alignment Model...PPALIGN  
String.....MC1S  
Prelim. Alignment Model  
String  
Final Alignment Model  
String

**Plan Prep Cross Sections**

Master Alignment Model:.....PPALIGN  
Master Alignment Name:.....MC1S  
Triangle String: .....TX00  
Cross Section Model:.....PPSECTMC1S  
Cross Section Label: .....D

**Existing Cross Sections**

Master Alignment Model:  
Master Alignment Name:  
Description:  
Triangle String:  
Cross Section Model:  
Cross Section Label:

**Proposed Cross Sections**

Design Model:  
Master Alignment Name:  
Description:  
Triangle String:  
Cross Section Model:  
Cross Section Label:

## DIRECTORY STRUCTURE

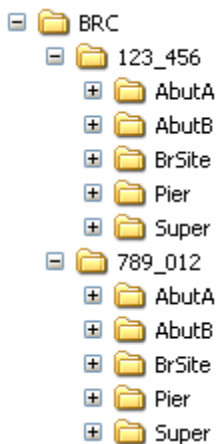
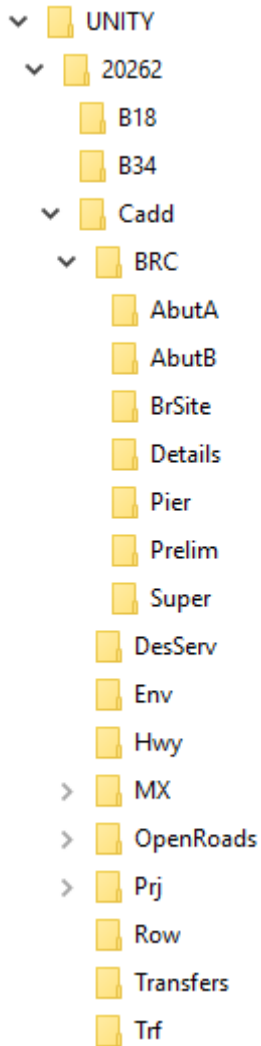

The standard directory structure being used for CAD/D projects within NHDOT is shown below: Directory and file names will only contain alphanumeric characters, dashes (“-”) and underscores (“\_”). Spaces in file names should be avoided whenever possible. Since every project is unique, file structure will vary. A representative example is shown here.

CAD/D files are stored in directories under the *Cadd* folder.

Files that are used with MicroStation or by multiple bureaus are stored in the *Prj* folder.

The following folders will contain files that are only pertinent to that particular bureau:

*BRC* – Bridge Design

*DesServ* – Design Services

*Env* – Environment

*Hwy* – Highway Design

*MX* – Data and drawings associated with MX. Being retired as NHDOT transitions to OpenRoads.

*OpenRoads* – Data and drawings associated with OpenRoads. It includes separate folders for *Preliminary* and *Final Design* alternatives.

*Row* – Right of Way

*Trf* – Traffic

The *BRC* folder contains the following subdirectories:

*AbutA* - Detail plans depicting Abutment A footing, masonry, and reinforcing.

*AbutB* - Detail plans depicting Abutment B footing, masonry, and reinforcing.

*BrSite* - General Plan, Site Plan, notes, and boring logs.

*Details* - Miscellaneous details, for example Bridge and Approach Rail.

*Pier* - Detail plans depicting Pier footing, masonry, and reinforcing.

*Prelim* - Preliminary Plans. After preliminary plans are accepted, pdf files of the Genplan & Siteplan drawings are created. Other drawings are copied into this directory and renamed.

*Super* - Superstructure details.

The *CutSheet* folder under *Prj* is where Highway Design's final contract plan DGN files will be stored. Front sheets are stored in the *FrontSheet* folder under *Prj*. Right-of-Way drawings will be stored in the *ROWPlans* folder under the *CutSheet* folder. Bridge Design contract plan files are stored in the various Bridge directories.

If there are multiple bridges on a project, the *BRC* directory structure is typically modified so that drawings for each bridge are kept separate. The subdirectories under *BRC* can be named for the feature being crossed or in cases where the same feature is crossed multiple times, the bridge number as shown here.



## PART III – MICROSTATION

### MICROSTATION WORKSPACE

Through a collaborative effort, the NHDOT has made available a spreadsheet (nhdotdownloads.xls) to clarify how to best and most easily utilize the files provided for download on the DOT's website. The spreadsheet and associated readme files found in the workspace download from the CAD/D website should provide the information necessary to duplicate the intent of the MicroStation workspace used at NHDOT. This will aid the consultant in producing plans that meet the expectations laid out in the Department's "CAD/D PROCEDURES AND REQUIREMENTS" document with minimal interference to a site's established workspace.

### FILE NAMING

An attempt shall be made to have MicroStation files named using only an eight character file name with a .DGN extension. However, it is understood that this will not always be possible or preferable. Directory and file names will only contain alphanumeric characters, dashes ("-") and underscores ("\_"). Spaces in file names should be avoided whenever possible. The current list of drawing names can be found in the MicroStation section of the CAD/D website at the address listed in the *DOCUMENTATION* section on page 7 of this document.

### LEVEL ASSIGNMENTS AND SYMBOLOGY

The files mentioned in this section are available on the CAD/D website or can be requested through the Project Manager. The website address is listed in the *DOCUMENTATION* section on page 7. Once at the CAD/D Homepage, select the Downloads link.

Level library files contain level names and color/weight/style information for MicroStation .DGNs. For Highway Design there are level library files available for most plan drawings. These files have the same 3-character name as the drawing plus a .csv extension. For example, the level naming file for drawing *12345exd.dgn* will be *exd.csv*. Level libraries are attached through MicroStation's Level Manager.

There are two CSV files to be utilized when creating DGNs for the Bureau of Bridge Design. The first file is called *brc.csv*, and stands for BRidge Cut-sheet. It contains the names required to accurately place graphical elements on a cut sheet (also referred to as a detail sheet). The second file, called *brd.csv*, contains the names required to place graphical elements in a .DGN at project coordinates. Many of the names in *brd.csv* are required in order to convert elements to MX from MicroStation.

Level standards for front sheets are in *fsh.csv*, and for all other cut sheets in *bxx.csv*. Filters for displaying borders are included in *BorderFilters.dgnlib*.

Standard plan drawings are not maintained by the CAD/D Section. The latest copies can be found on the NHDOT website ([www.nh.gov/dot](http://www.nh.gov/dot) → Doing Business with DOT → Engineers/Consultants → Standard Plans for Road Construction). Symbol sheets can also be found on the NHDOT website ([www.nh.gov/dot](http://www.nh.gov/dot) → Doing Business with DOT → Engineers/Consultants → Detail Sheets – Highway Design)

Line weights, styles and text heights are set by task menus for the various types of drawings. The task menus are described in more detail in *DRAWING QUALITY ASSURANCE / QUALITY CONTROL* on page 35. Use of NHDOT-defined MicroStation linestyles is required. The consultant, with the approval of the Project Manager, may create symbols that are not covered in the NHDOT Design Manual or contained in NHDOT cell libraries that are needed to complete project plans. Resource files containing any linestyles and/or symbols created by the consultant for use on the project drawings will be provided to NHDOT.

MicroStation symbols, including standard borders, are contained in NHDOT's standard cell libraries and are available in MicroStation .CEL file format. A standard color table, linestyle resource files with NHDOT linestyles and font library with NHDOT fonts for use with MicroStation are available for download.

## REFERENCE FILE ATTACHMENTS

A reference file is a MicroStation drawing or other CAD/D file attached as a background to an active design file, thus allowing several design groups to share the same information without the need to copy the file(s). MicroStation and MX can attach a reference file by one of three different ways:

1. Name only – the path to the referenced file is resolved by the MicroStation configuration variable MS\_RFDIR.
2. Relative path – the reference file name and its location relative to the master file.
3. URL address – the file is attached in the form of a URL address using relative paths.

In order for a project to be delivered to NHDOT in an electronic format that will allow future use of the files for printing purposes without modification to the files, the reference files must be attached in a way that will allow MicroStation or MX to resolve the reference file attachment paths regardless of the drive or parent directory of the project. Option 1 above is the preferred method for NHDOT projects, since it allows the files to be moved from drive to drive without losing the reference file attachments. However, this option requires the MicroStation configuration variable, MS\_RFDIR, be set for all NHDOT projects.

## SEED FILES

MicroStation uses “seed” files to create all design files. These seed files are templates in which standard parameters are set according to what is needed to begin drafting for a specific type of work in accordance with NHDOT standards. Seed files allow the user to begin work in a standard format and maintain uniformity. The seed file defines the working units for the file, coordinate system, view attributes, default color table, text settings, coordinate readout and several other important parameters. NHDOT supplies seed files for both 2D and 3D drawings.

NHDOT design teams are working with both 2D and 3D MicroStation drawings. As a general rule, drawings strictly used for drafting are 2D while those which are also used within OpenRoads (survey and design files) will be 3D.

Working units are expressed as master units and fractional sub-units. The number of positional units per sub-unit is called the working resolution. The working resolution determines the precision to which elements are drawn. The format for the working units in MicroStation is defined as MU:SU (master units, sub-units).

In late 2016, NHDOT started creating new project files with Working Units of U.S. Survey Feet. Projects started with the International Foot seed files will generally continue to use those units. This was done to correct an inconsistency created when U.S. Survey Foot units became an option within MicroStation. Coordinates used for survey and design had always been in U.S. Survey Feet even though the DGN files had Working Units of "Feet". The working units of the drawings for any particular project must be noted in the Project Journal File.

U.S. Survey Foot seed files are identified by having "-USSF" appended to the file name.

**SEED FILES (2D & 3D)**

Working Units:

- Master Units ..... U.S. Survey Feet
- Sub-Units ..... U.S. Survey Inches
- Resolution ..... 10000/U.S. Survey foot
- Geographic Coordinate System:  
 ..... NH83/2011F

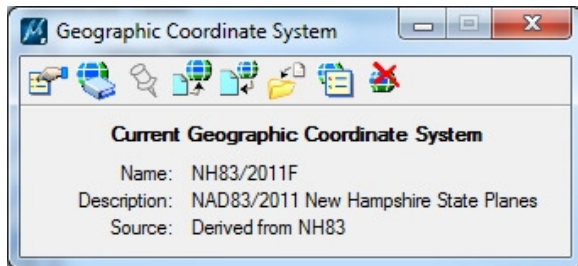
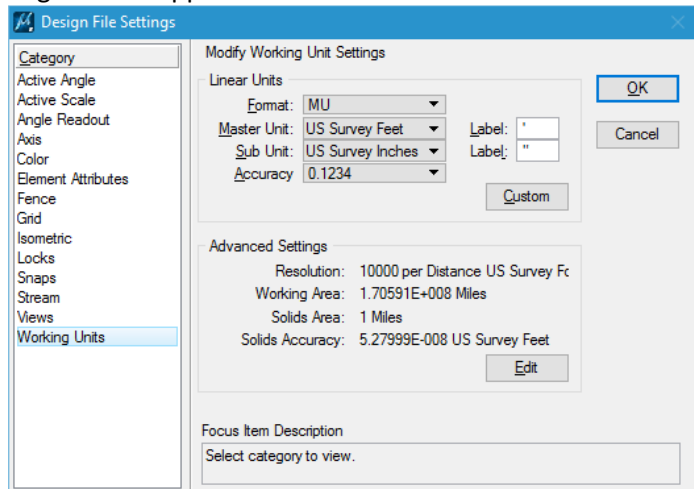

The Geographic Coordinate System (GCS) has been set to NAD83/2011F New Hampshire State Plane coordinate system. Using these coordinates, the seed files can be used for both drawings based at State Plane Coordinates and drawings, such as cross-sections, profiles, typicals and special details, using a local coordinate base.

Designers should confirm which coordinate system was used during the survey of the project and adjust the Geographic Coordinate System of the drawing files if necessary before developing the drawing.

## FONTS

MicroStation font resource files are binary files created from font cells, TrueType, Postscript, or AutoCAD SHX fonts. MicroStation will read multiple font resource files according to the paths set by the MS\_SYMBRSC configuration variable in the selected workspace. However, within MicroStation they are compiled into a list of all the fonts from all the resource files that were found. If one file contains a font with the same number assigned as another font resource file, the user will see the last one located.

The NHDOT font resource files are called *nh-custom-font.rsc* & *nhttfont.rsc*. Any fonts within the NHDOT resource files that are no longer in use will be maintained for backward compatibility purposes. The fonts contained within the NHDOT resource files are described below. Font numbers below 170 are reserved for standard MicroStation fonts.

### **NH-CUSTOM-FONT.RSC**

| Font | Description  |
|------|--|
| 180  | nh_engineering (Engineering w/bridge and drafting symbols) Non-alphanumeric characters contained within this font are pictured in <i>APPENDIX C - NHDOT CUSTOM LIFESTYLES &amp; FONT</i> on page 49. |

### **NHTTFONT.RSC**

| Font | Description                         |
|------|-------------------------------------|
| 170  | True Type font Arial                |
| 171  | True Type font Arial Bold           |
| 173  | True Type font Courier              |
| 174  | True Type font Courier Bold         |
| 176  | True Type font Times New Roman      |
| 177  | True Type font Times New Roman Bold |
| 182  | True Type font Comic Sans           |
| 183  | True Type font Comic Sans Bold      |



## TEXT HEIGHT AND SPACING

Standard text heights and fonts have been defined to ensure uniformity and legibility on all CAD/D drawings. The correct text height is shown on the level mapping table and is dependent on the plot scale. Note that the text height listed represents both the text height and width. Since, the most important issue with text is that it should be legible, font and text height may vary if absolutely necessary. Text line spacing varies between half of the text height and the text height depending on the use.

## TEXT STYLES

For bridge drawings, text styles are available at various engineering and architectural scales. The styles are located within nhdotTextandDimStyleLibraryFT.dgnlib (Imperial).

These dgnlib's should be defined by the MS\_DGNLIBLIST variable. The style names include the intended purpose of the text and the scale of the drawings they will be used on.

|                   |                                      |
|-------------------|--------------------------------------|
| nh_eng            | Used for note and detail text        |
| Title nh_eng      | Used for detail title text           |
| Note Title nh_eng | Used for a smaller or sub-title text |

Dimension and text style libraries used by Bridge Design are available on the NHDOT CAD/D website.

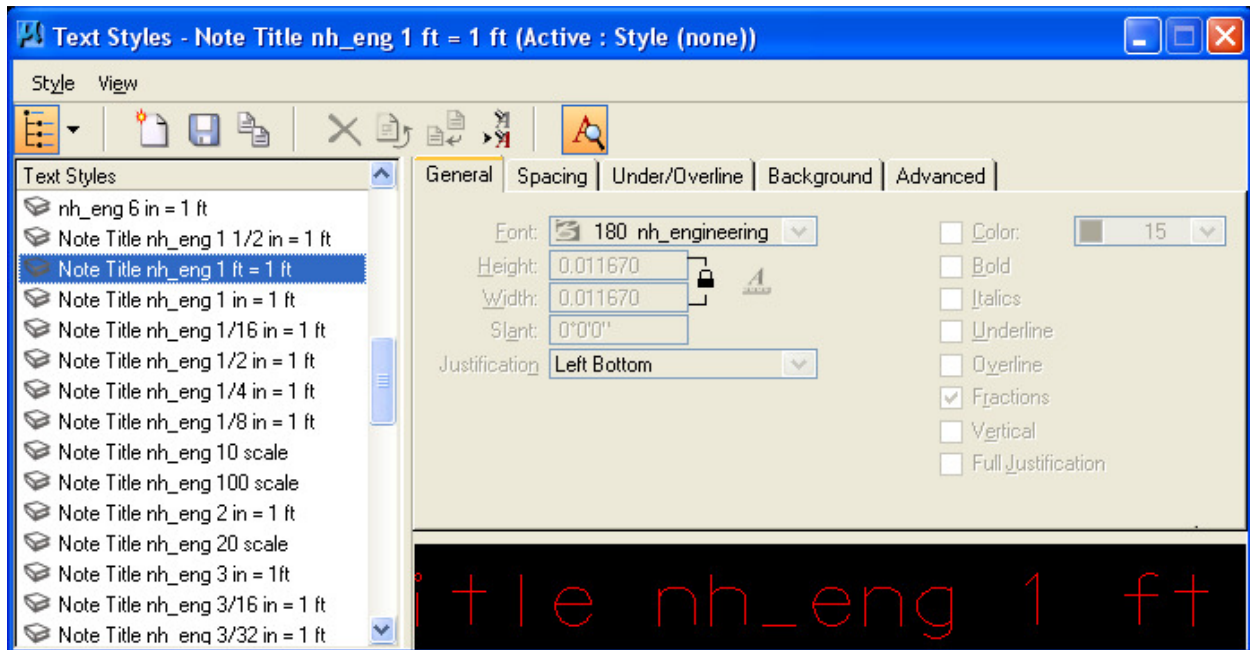

## LINESYLES

Line style is part of the symbology of graphical elements in MicroStation. An element can be set to the standard MicroStation linstyles (numbered 0 - 7) or to a custom linstyle defined in a custom linstyle resource file. Custom linstyles are user definable resource files for the display of different patterns, for example, a tree line, fence line, guardrail, etc. When an element is drawn in MicroStation with a custom linstyle, the definition of the linstyle is not contained within the design file. The resource file from which it was selected must be packaged with the design file and it must be found by MicroStation's configuration in order to properly display the line. Therefore, users are strongly discouraged from creating their own custom linstyles. Use the NHDOT supplied custom linstyle resources whenever practical. Graphical depictions of NHDOT MicroStation linstyles are shown in *APPENDIX C - NHDOT CUSTOM LINESYLES & FONT* on page 49.

### NHDOT CUSTOM LINSTYLE RESOURCE FILES

|                                      |
|--------------------------------------|
| Standard NHDOT Custom linstyle files |
| line-ft.rsc                          |
| pipe-ft.rsc                          |

As mentioned above, custom linstyles are user definable in MicroStation. NHDOT linstyles are created at two different scales (1:1 and 1"=50') depending on the intended use. These settings are included in the task menus. The task menus are described in more detail in *DRAWING QUALITY ASSURANCE / QUALITY CONTROL* on page 35.

Caution must be exercised as the definition for the linstyle is maintained in a resource file and a design file only contains links to custom linstyle resource files. If a new (non-standard) custom linstyle is developed by a user, those resource files must be delivered with the project. Users shall not modify the NHDOT delivered standard custom linstyle files.

### TRUE SIZE LINESYLES

Linstyles that are defined to be a specific size (such as pipe and railroad styles) should always be drawn at a scale of 1. Styles in this group include:

|          |               |            |
|----------|---------------|------------|
| BmGrDbI  | CurbRt        | PipeP#     |
| BmGrLt   | DrainPipe     | Railroad   |
| BmGrRt   | JerseyBarrier | SheetPile  |
| CblGrLt  | PCurbLt       | TrafBarls  |
| CblGrRt  | PCurbRt       | UnderDrain |
| CblGrMed | Pavemark      | XPipE#     |
| CurbLt   | PipeE#        | XPipP#     |

**SCALED LINSTYLES**

Linestyles for plan drawings have been created for use on a 1"=50' scale Imperial drawing. This includes most of the linestyles available. When these linestyles are used on 1"=20' Imperial drawings, they should be scaled by 0.4. Charts showing scale values for other drawing scales are shown below.

**CUSTOM LINSTYLE SCALING CHARTS**

**Imperial**

| Scale for plotting | Ratio  | Custom linestyle scale setting |
|--------------------|--------|--------------------------------|
| 1"=1"              | 1:1    | 0.0016                         |
| 6"=1'              | 1:2    | 0.003                          |
| 3"=1'              | 1:4    | 0.006                          |
| 2"=1'              | 1:6    | 0.01                           |
| 1 1/2" = 1'        | 1:8    | 0.013                          |
| 1" = 1'            | 1:12   | 0.02                           |
| 3/4" = 1'          | 1:16   | 0.026                          |
| 1/2" = 1'          | 1:24   | 0.04                           |
| 3/8" = 1'          | 1:32   | 0.053                          |
| 1/4" = 1'          | 1:48   | 0.08                           |
| 1" = 5'            | 1:60   | 0.1                            |
| 3/16" = 1'         | 1:64   | 0.1066                         |
| 1/8" = 1'          | 1:96   | 0.16                           |
| 1" = 10'           | 1:120  | 0.2                            |
| 3/32" = 1'         | 1:128  | 0.2135                         |
| 1/16" = 1'         | 1:192  | 0.32                           |
| 1" = 20'           | 1:240  | 0.4                            |
| 1" = 30'           | 1:360  | 0.6                            |
| 1" = 50'           | 1:600  | 1                              |
| 1" = 100'          | 1:1200 | 2                              |

### LINESTYLES CREATED AT 1:1

The *line-ft.rsc* file also contains custom linestyles created at a scale of 1:1. In order for these lines to be properly proportioned, the user must enter the scale associated with the plot size of the drawing in the Linestyles dialog box for custom linestyles before placing the line. The linestyles for which this rule applies include:

|          |            |            |
|----------|------------|------------|
| ArBegOpn | BreakBr    | LeaderBr   |
| ArBegSld | BreakDimBr | LedgeBr    |
| ArEndOpn | DimBr      | RocklineBr |
| ArEndSld | GroundBr   |            |
| ArrowBr  | ITS-Prop   |            |

There are multiple ways to alter the scale of linestyles on a drawing. To set the scale, select *Element* → *Line Style* → *Custom*. Select the linestyle, check the "Scale factor" box and enter the desired scale. Click on the graphic representation of the linestyle to implement the change. An alternative way is to issue the key-in *dwg celtscale #* where the # is replaced with the desired scale. Future lines will be drawn at the new scale. To alter the scale of linestyles that have already been drawn, select all the elements to be changed. Issue the *Change Linestyle Scale #* key-in replacing the # with the desired scale.

### COLOR TABLE

A standard color table is necessary to provide visual consistency thus allowing users to easily identify elements in shared files and for consistency in color plotting. NHDOT has its own default color table called *nh-color.tbl*. The table defines 256 colors from which an active color can be selected and applied to an element. NHDOT's black and white plotters are configured to print all colors except 10-14 in black. Colors 10-14 will plot in the shades of gray displayed in MicroStation.

### CROSS HATCHING

Cross-hatching used by Bridge Design is shown on the next page.

| Architect     | Hatch spacing |      |
|---------------|---------------|------|
|               | in            | ft   |
| 1/16" = 1'-0" | 24            | 2.00 |
| 3/32" = 1'-0" | 16            | 1.33 |
| 1/8" = 1'-0"  | 12            | 1.00 |
| 3/16" = 1'-0" | 8             | 0.67 |
| 1/4" = 1'-0"  | 6             | 0.50 |
| 3/8" = 1'-0"  | 4             | 0.33 |
| 1/2" = 1'-0"  | 3             | 0.25 |
| 3/4" = 1'-0"  | 2             | 0.17 |
| 1" = 1'-0"    | 1.5           | 0.13 |
| 1.5" = 1'-0"  | 1             | 0.08 |
| 2" = 1'-0"    | 0.75          | 0.06 |
| 3" = 1'-0"    | 0.5           | 0.04 |
| 6" = 1'-0"    | 0.25          | 0.02 |
| 12" = 1'-0"   | 0.125         | 0.01 |

| Highway   | in  | ft    |
|-----------|-----|-------|
| 1" = 100' | 150 | 12.50 |
| 1" = 50'  | 75  | 6.25  |
| 1" = 30'  | 45  | 3.75  |
| 1" = 20'  | 30  | 2.50  |
| 1" = 10'  | 15  | 1.25  |

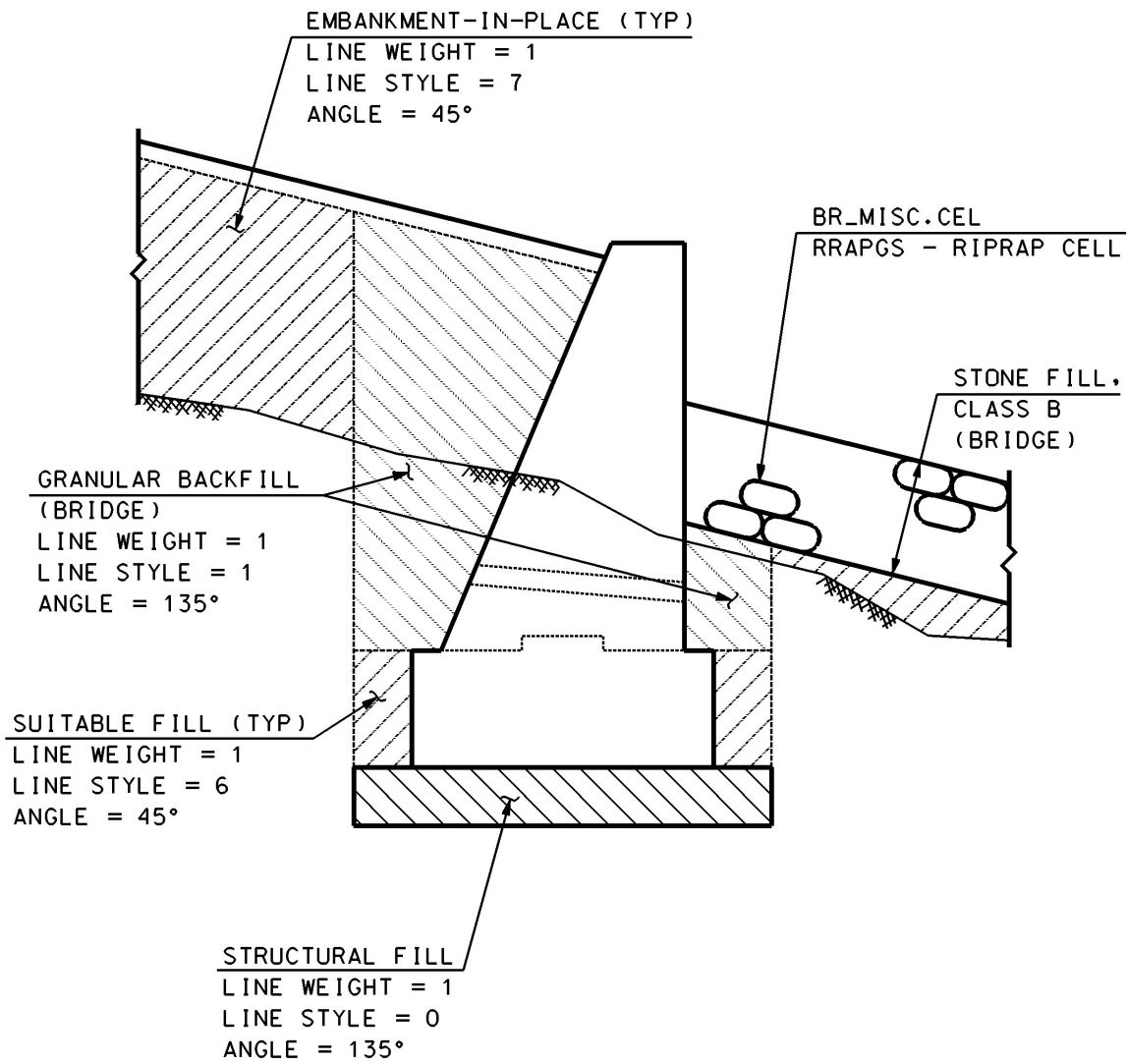

## BRIDGE DESIGN TYPICAL HATCHING

SCALE:  $\frac{3}{8}'' = 1' - 0''$

## CELL FILES

The following graphic cell files have been created for use on NHDOT projects. Items shown in *italics* have been added since the previous edition.

|                 |  |               |  |
|-----------------|--|---------------|--|
| alignment.cel   | symbols for alignment transfers and ms tasks   | environ.cel   | environmental detail cells             |
| borders.cel     | cut sheet borders (including front sheets, ROW summary, property layout and xsection borders and their text cells) | exist-in.cel  | existing topography cells              |
| br_Borders.cel  | miscellaneous bridge borders   | geotech.cel   | geotechnical cells                     |
| br_bore.cel     | boring sheet symbols   | grdrail.cel   | proposed guardrail detail cells        |
| br_Misc.cel     | rip-rap, slope lines, waterstops, sheet piles, section A-A, North arrow, shear connector, & RR section             | legends.cel   | hearing plan legends                   |
| br_pile.cel     | HP sections and Pile Key   | logos.cel     | NHDOT and other logos                  |
| br_precast.cel  | New England Bulb Tees (precast concrete beams)   | notes.cel     | project begin/end notes                |
| br_Rail.cel     | 2 bar, 3 bar aluminum and T2,3,4 steel bridge and approach rails   | pavemark.cel  | proposed pavement marking detail cells |
| br_Railmisc.cel | existing/superseded, temporary, and Texas 101 bridge and approach rails  | profile.cel   | cells for profile drawings             |
| br_weld.cel     | weld symbols   | row.cel       | proposed right-of-way detail cells     |
| drainage.cel    | proposed drainage detail cells   | signals.cel   | proposed signalization detail cells    |
|                 |  | signs.cel     | proposed sign detail cells             |
|                 |  | stamps.cel    | miscellaneous roll/plan sheet cells    |
|                 |  | StnOffset.cel | Station–Offset macro cells             |
|                 |  | turnrad.cel   | Imperial turning radii templates       |
|                 |  | utility.cel   | proposed utility detail cells          |
|                 |  | xsect.cel     | cross-section detail cells             |

The following pattern cell file has been created for use on NHDOT projects.

nhpatern.cel      hearing plan removal patterns

Cells from Bentley's archpa.cel may also be used.

Additional cell files used for OpenRoads are included in the OpenRoads section.

## DIMENSIONING

Dimensions should appear as shown in the Highway Design Manual with the following exception: The dimensions for Bridge detail drawings shall be placed to have the appearance of those that follow:

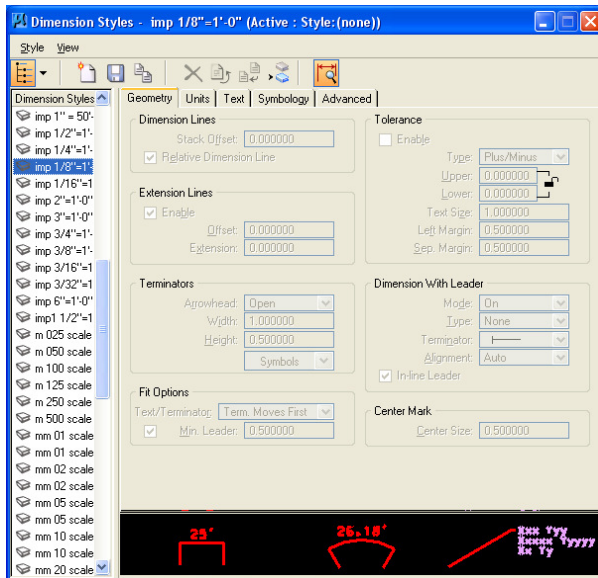

The use of Dimension Styles is strongly encouraged for the placement of all dimensions on structural design drawings, since, at a minimum, it will select the proper text height. It is understood that in order to achieve the dimension appearances shown above, the Dimension Style defaults will, at times, need to be overridden.

Dimension style names reflect the scale.

Dimension and text style libraries are available on the NHDOT CAD/D web site.

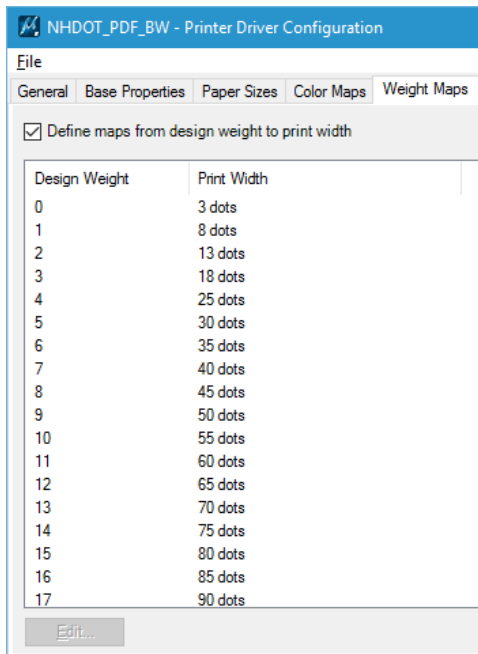

## PLOTTING

The plotter configuration file (file extension .PLTCFG) is used to set default plotter settings. Black and white plot configuration files have been modified to force all pen colors to black except pens 10-14 which are defined as various shades of gray in the NHDOT color table. Line weights for full size plotters are as indicated in the graphic.

Plotter driver files should be edited for plotter specific adjustments only. Changes intended to affect all plots should be made in the pen tables.

Plot configuration files for creating PDF files are included in the workspace downloads available on the CAD/D website. Information about creating PDF files is in the MicroStation section of the website.

## PRINT ORGANIZER

To plot cut sheets, a rectangular element drawn on level Border and in color 84, style 0, weight 0 has been placed at the outer edge of NHDOT border cells. A print style, *BorderLevelandColor*, was created for Print Organizer to use this element as a boundary when plotting cut sheets. When developing CAD/D drawings, elements of this color, style and weight should be avoided unless an element defining a batch print limit is being created.

## PEN TABLES

A pen table is used to alter the way a drawing is sent to the plotter. It can be used to control the levels that are plotted, control the order in which they are plotted, make text substitutions, or run macros at plot time. NHDOT uses a pen table called nhdot-pen.tbl to make a number of text substitutions in plan borders and front sheets. The variables that are substituted are typically defined in the project configuration file (pcf). Items added since the previous version of this document are shown in *italics*. Currently defined substitutions include:

| Drawing text         | Text substitution                | Description   |
|----------------------|----------------------------------|---|
| \$PROJCLASS\$        | \$(PROJCLASS)                    | Project class   |
| \$STNO\$             | \$(STNO)                         | State project number                                    |
| \$SCALE\$            | \$(NH_SCALE)                     | Project scale   |
| \$FEDNO\$            | \$(FEDNO)                        | Federal project number                                  |
| \$NHPROJ\$           | \$(NHPROJ)                       | "N.H. PROJECT NO. 12345"                                |
| \$ROUTENO\$          | \$(ROUTENO)                      | Route number or road name                               |
| <i>\$ROUTENAME\$</i> | <i>\$(ROUTENAME)</i>             | <i>Road name on Right-of-Way registry plan borders</i>  |
| \$CSHTOT\$           | \$(CSHTOT)                       | Total number of construction plan sheets                |
| \$LSHTOT\$           | \$(LSHTOT)                       |   |
| \$MRSHTOT\$          | \$(MRSHTOT)                      | Total number of Materials & Research plan sheets        |
| \$RSHTOT\$           | \$(RSHTOT)                       | Total number of right-of-way plan sheets                |
| \$SSHTOT\$           | \$(SSHTOT)                       | Total number of shoreland plan sheets                   |
| \$WSHTOT\$           | \$(WSHTOT)                       | Total number of wetland plan sheets                     |
| \$BT\$               | \$(BT)                           | Total number of bridge sheets                           |
| \$PBT\$              | \$(PBT)                          | Total number of preliminary bridge sheets               |
| \$BRNO\$             | \$(BRNO)                         | Bridge inventory number                                 |
| \$BRDESCR\$          | \$(BRDESCR)                      | Bridge description (road over feature crossed)          |
| \$BRFILNO\$          | \$(BRFILNO)                      | Bridge file number                                      |
| \$BRDIR\$            | \$(lastdirpiece(_DGNFILE))       | Bridge directory  |
| \$TIME\$             | _TIME_                           | Current time  |
| \$FILE\$             | _FILE_                           | DGN file name   |
| \$USER\$             | \$( _USTN_USERNAME)              | User name   |
| \$DATE\$             | _DATE_                           | Current date  |
| \$FILENAME\$         | \$(basename(_DGNFILE))           | DGN file name without directory path                    |
| \$ROWTOWN\$          | \$(ROWTOWN)                      | "TOWN OF -----"   |
| \$COUNTY\$           | \$(COUNTY)                       | County name   |
| \$TOWN\$             | \$(TOWN)                         | Project Name (Town)                                     |
| \$MODELNAME\$        | _MODELNAME_                      | Model name  |
| \$REVNUM\$           | \$(REVNUM)                       | Right-of-Way plan revision number                       |
| \$REVDATE\$          | \$(REVDATE)                      | Right-of-Way plan revision date                         |
| \$PROJNAMENUM\$      | \$(PROJNAMENUM)                  | Partial file path to project folder                     |
| <i>\$PSETNO\$</i>    | <i>&lt;expr?name=Snumber&gt;</i> | <i>Sheet number from Print Organizer file</i>           |
| <i>\$PSETTOT\$</i>   | <i>&lt;expr?name=Stotal&gt;</i>  | <i>Total number of sheets from Print Organizer file</i> |
| <i>\$REGDATE\$</i>   | <i>\$(REGDATE)</i>               | <i>Registry Plan submission date</i>                    |



## PART IV – OPENROADS

### INTRODUCTION

Bentley's decision to replace their three different Civil Design software packages, (MX, InRoads and Geopak), with OpenRoads provide the opportunity for NHDOT staff to exchange Civil Design data with consultants regardless of which package they used. NHDOT has been aggressively testing and internally promoting the use of OpenRoads updates as they are released. Consulting firms should be aware that software updates are likely to occur in between updates to this document. When receiving a new project, one should check with the Project Manager or CAD/D staff to confirm which version of the Civil Software was used for the project's design up to that point.

NHDOT has begun providing 3D design data to construction contractors for use in electronic field survey equipment and GPS-guided construction vehicles. The transition from MX design to OpenRoads has provided more complete 3D designs for these projects.

### FILE NAMING

OpenRoads files should be named in such a way that someone unfamiliar with the project can figure out what the file is for. Similar to MicroStation drawings, OpenRoads file names should always begin with the project number.

### SEED FILES

OpenRoads seed files vary from those used by MicroStation. The primary difference is the inclusion of a 3D model in the OpenRoads seed files. Additional details can be found in the MicroStation *SEED FILES* section on page 16.

### OPENROADS DRAWING NAMES

A naming convention for OpenRoads drawings has been established. To reduce the potential for errors and conflicting data, this information is not included in this document. The current naming conventions can be found within the OpenRoads section of the CAD/D web-site at the address listed in the *DISCLAIMER* section of this document.

### TEMPLATE FILES

Templates are used to create corridors. Each template is basically a typical section that contains the features and components that are extruded along a civil geometry. Since each project is unique and will likely need modification to any standard template, a "seed" template file has been created - 00000NHDOT-IMP.itl which contains templates developed by the NHDOT. When working in a new project, 00000NHDOT-IMP.itl should be copied into appropriate folder for that project. When using MX,

that is the project's */MX/imperial\_styles* directory. InRoads and Geopak likely have their own location for this file. The file would then be renamed to replace the "00000" with the state project number. The template files obtain their component feature definitions from two dgnlib files, RWDSC.DGNLIB and RWDSC2.DGNLIB. Roadway linear feature definitions come from the NHDOT-Road-Features.dgnlib.

## OPENROADS CELL FILES & LINSTYLES

3D linstyles which can be used in OpenRoads and for the Subsurface Utility Engineering features are still being developed. These linstyles are used to represent linear features such as guard rails in 3D views. Once they are ready, they will be available for download from the CAD/D website.

The 3D linstyles which are available as of this writing are contained within two resource files -gr-post.rsc and Civil\_Custom\_Linstyles\_PVM.rsc. Additional linstyles will be available for download as they are developed.

## CIVIL CELLS

Sample Civil Cells for driveways and side roads are available in *nhdot-civil-cells.dgnlib* which is included in the files available for download from the CAD/D website. Additional libraries will be added in the future.

## MX-SPECIFIC NOTES

Although NHDOT is moving away from MX design to OpenRoads, this information is being retained for reference when working on older projects.

### MX FILE NAMING

MX projects are typically given names beginning with the town name followed by the state project number. For example: *Concord 12345.mmd*. It is not uncommon for the MMD file name to also include an indication of the MX version being used for the design, i.e. *Concord 12345 SS4.mmd*. Other file types are listed in the table below.

| Type    | Extension | Portability | Description   |
|---------|-----------|-------------|---|
| Input   | .INP      | MX Only     | Used to store line mode commands to create or modify MX strings   |
| Output  | .PRN      | MX Only     | Used to store the results of an input file or interactive commands  |
| Draw    | .DRW      | MX Only     | An input file that is used to create a display using a drawing macro or major option DRAW and/or ENHANCE commands |
| Journal | .JOU      | MX Only     | A journal file stores commands issued during an MX session so they can be rerun at a later time                   |

## **MX MODEL NAMING**

Suggested MX model names are listed in *APPENDIX D – MX Model Naming Convention*, on page 53. Any variations from this convention shall be noted in the project journal file.

## **MX STRING LABELING**

MX data is contained in strings and the strings are contained in models. Each string has a unique four-character label. Typically the first two characters of the string label are used to identify the type of string. NHDOT's string labeling convention can be found in the MX section of the CAD/D website at the address listed in the *DOCUMENTATION* section on page 7.

## **MX STYLE SETS**

A style set is a collection of styles which is used to draw a complete model or a selected part of it. Beginning with MX v8i, style set references to MX macro symbols and macro lines have been replaced with MicroStation cell and linestyle references. NHDOT style and features sets are stored on the network in MX's Public folder so they are accessible to all users. This eliminates the need to upgrade each workstation when changes are made.

## **MX FEATURE SETS**

Feature sets are a means of grouping strings and identifying them with a description. They are used throughout MX to make it easier to select strings for subsequent operations. The strings belonging to a feature set are specified using a partial string name, and are drawn with a style set (usually having the same name as the feature set).

For design detail, NHDOT uses a modified version of *mxroad.fns* provided by Bentley to conform to MX design wizards. When transferring detail between MX and MicroStation, be aware that MicroStation elements are drawn based on the model's default style set. This should be the same style set that was used to draw the MX DPW/DPF.

The MX style sets are also used to display OpenRoads survey detail until OpenRoads Designer is implemented. When transferring OpenRoads alignments to and from MX, *OpenRoads.pss* and *OpenRoads.fns* should be set as the style and feature sets.

A table of NHDOT MX style and feature sets is on the MX section of the CAD/D website.

## **CROSS-SECTION SETTINGS FILES**

Cross sections and profiles can be generated in a number of different ways. Using the cross-section wizard within MX allows the user to save parameters defining the cross-section set. These saved settings files have a .CSU extension and are stored in the project directory. The settings file will define the type of sections cut (based on the cross-section feature set used), models selected, and information about any special stations or skewed sections. By default, the cross-section wizard uses the information in the cross section model's default style set to determine the different types of cross-sections. String labels for cross sections are listed in *APPENDIX G – CROSS SECTION SET LABELS* on page 57. For NHDOT projects, the default cross-section style set and feature set are listed in the table on the previous page.

**ADD-INS**

MX Add-Ins are applications such as Visual Basic programs that can interact with MX. NHDOT has developed a number of these programs to simplify some operations. These programs and their descriptions are available on the CAD/D website.

## PART V – PROCEDURES

### INTRODUCTION

This section offers summaries of some NHDOT CAD/D procedures. It is not intended to provide an in-depth discussion of any particular topic. For more details, refer to the CAD/D website.

### EXCHANGING RIGHT-OF-WAY DATA

Right-of-way data is routinely updated during the project's lifetime. This information is typically maintained by the NHDOT Bureau of Right-Of-Way for both in-house and Consultant-designed projects. Knowing that DOT staff and Consultants both need to work on the existing right-of-way drawings, a process has been developed to ensure that this data is kept current and accurate.

The existing right-of-way information will be divided between multiple drawings. One contains the line work (ERL) a second will have the text information (ERT). Some projects may also have a third drawing containing digitized right-of-way information (ERD). It is intended that the Department will maintain the master ERL drawing (abstracting) and send the consultant a copy when updates have been made.

The Bureau of Right-Of-Way will continue to utilize Design History and that record will be maintained throughout the life of the project. This is in line with how business was conducted when the process included the ROW Abstracting mylar. The Bureau of Right-Of-Way will continue business as usual with the ability to make changes at any time during the design process with the understanding that the NHDOT Consultant Reviewer will be notified when changes have been made.

The process shall be:

- ERT and ERL drawings are created by the Bureau of Right-Of-Way and Design History is turned on. Under normal circumstances, only the NHDOT Bureau of Right-Of-Way should be making changes to the ERL drawing.
- The Consultant receives a copy of the ERT drawing. At their discretion, the Consultant is free to adjust text position or make other cosmetic changes to improve legibility of the drawings.
  - Updates to parcel ownerships made by the NHDOT abstractors are revised on the ERT drawing and a copy of the updated ERT drawing is sent to the Consultant. The Consultant will be responsible for updating their copy of the ERT drawing. Design History can be used to highlight changes and text revisions made to the ERT drawing by NHDOT staff.
- The Consultant also receives a copy of the ERL drawing which is referenced into other drawings (Not copied or merged).
  - Updates to property lines, ROW lines, easement lines etc. are made to the ERL.dgn by NHDOT Bureau of Right-Of-Way staff and a copy is sent to the Consultant. The revised ERL.dgn supercedes all previous versions.
  - Updates to the ERL.dgn can be reviewed using the Design History to identify changes and impacts to the property line and ROW line locations

- Right-of-way data is submitted in both paper and DGN format to NHDOT Bureau of Right of Way for review and approval prior to the production of recordable plans.

## LEGACY ALIGNMENTS

Prior to the implementation of a CAD/D system in the 1980's, it was customary to show alignments of former projects on plan drawings as a reference between the old and new projects. Computer-aided design, electronic survey equipment and advancement in GPS technology eliminated the need to reference former alignments when creating new ones. As a result, former project data was no longer shown on the plan drawings.

The Bureau of Right-of-Way has expressed a need to reference this historical information to facilitate the locating of right-of-way boundaries that were laid out during these former projects. To assist this process, future projects are to include information about these "legacy" alignments. Whenever possible, this information should also be added to current projects.

The process includes:

- Researching former projects to identify those within the limits of the current project. On consultant projects, the Bureau of Right-of-Way will do the research.
- Obtaining alignment information from the as-built plans.
- Drafting that information onto the alignment drawing of the current project.

## USING OPENROADS TEMPLATES

Templates within the NHDOT-developed 00000NHDOT-IMP.itl can be modified as necessary to facilitate design of the project.

When templates from the template library are applied to the assigned horizontal and vertical geometry of a corridor, they are copied, not referenced, from the template library into the design file and are assigned station ranges. It is possible to drop different templates at defined station ranges to achieve changes in the roadway design. The template drop interval is the spacing that final templates will be dropped. Set this at a value appropriate for the project. For automated machine guidance construction, a rule of thumb is 5-ft between points on horizontal and vertical tangents and 1-ft between points where there is horizontal or vertical curvature or widening. Data points are also required at key stations, including horizontal and vertical geometry points, superelevation stations, offset geometry points, drainage facilities and guardrail and barrier limits.<sup>1</sup>

## ROLL PLANS

Project "roll-plan" file names are composed of three parts; the NHDOT state project number (first five characters), drawing type (last three characters), and the .DGN file extension.

---

<sup>1</sup> Recommendation from FHWA EDC-3 initiative "3D Engineered Models: Schedule, Cost and Post-Construction"

A further explanation of standard naming conventions and drawing type designators used by NHDOT can be found in the MicroStation section of the CAD/D website at the address listed in the *DISCLAIMER* section of this document.

## CUT SHEETS

The Highway Design group at NHDOT presently uses a method for preparing cut sheets where a single drawing is created for an entire set of drawings (general plans, drainage plans, etc.) with each sheet stored in a different model within the drawing file.

The drawing file names will be the project number followed by the type of drawing such as 12345genplans.dgn for the general plans of project #12345. Within this file there will be models for each individual sheet using the naming convention outlined in the following table. For example, the model for the first general plan sheet will be called GEN01.

For more details of the processes for developing cut sheets, see the documentation in the MicroStation section of the CAD/D website at the address listed in the *DISCLAIMER* section of this document.

Realizing that there are a number of different ways to accomplish this same task, variations to the method described above may be acceptable with prior approval of NHDOT. Consultants wishing to use an alternative method should contact the CAD/D Development Staff at the email address listed in the *DISCLAIMER* section of this document. Any deviations from these formats shall be noted in the Project Journal File. A listing of drawing type designators used by NHDOT is contained in the MicroStation section of the CAD/D Website.

## CROSS-SECTION DRAWINGS

With the transition to OpenRoads, cross-section drawings will be generated by OpenRoads and remain in that format, not exported to a native MicroStation format like MX drawings were. That will allow for updates to the cross sections if the design changes plus allow the ability to compute end area volumes and apply cross section labeling tools. Additional annotation can be applied with MicroStation when necessary.

Realizing that there are a number of different ways to accomplish this same task, variations to the method described above may be acceptable with prior approval. Consultants wishing to use an alternative method should contact the CAD/D development staff.

## BRIDGE DETAIL SHEETS

A single detail sheet frequently requires the placement of several details of various scales. To accomplish this, all details shall be drawn at a scale of 1:1 while using the NHDOT standard working units defined within the NHDOT seed files. The detail sheet shall be composed by applying scale factors to the self-referenced attachments of the detail drawing. The border of the detail sheet shall be a cell placed on the drawing at a scale of 1. Detail drawings shall not be created by either increasing the scale of the border or by temporarily adjusting the working units of the file, in any way.





## PART VI – OTHER PROJECT DATA

### DRAWING QUALITY ASSURANCE / QUALITY CONTROL

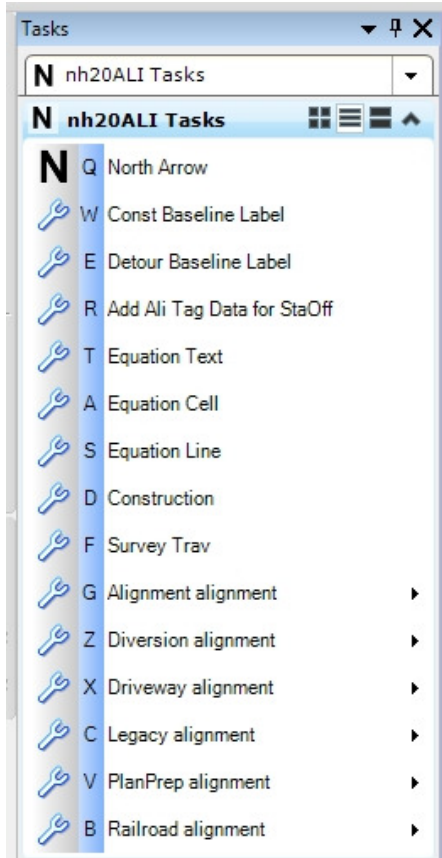

To aid the consultant and in-house staff in developing a set of contract plans that conform to the requirements contained in this document, NHDOT has developed a series of task menus for working on MicroStation drawings. Using the task menus provided will ensure that elements on the drawings are created according to the established MicroStation standards. At this time, use of the task menus is optional although their use is strongly encouraged.

The task menu system is composed of a collection of dgnlib files. The dgnlib files contain the element templates, tools, and tasks for the particular drawing type. Separate task menus have been created for each of the standard drawing names at both 50-scale and 20-scale. Metric files will be created when necessary. The task menu for 20-scale alignment drawings is shown here. The menu includes sections for the various types of alignments, each containing commands to set the level/color/style for drafting the particular feature.

For NHDOT operators, a macro checks the dgn name and project scale when a drawing is opened to determine the appropriate task list to load. If the dgn name is non-standard the NH50bxx Tasks are loaded assuming the dgn is a cut sheet type of drawing.



## PART VII - ENGINEERING CONSULTANT DELIVERABLE REQUIREMENTS

### OVERVIEW

The purpose of this section is to establish the minimum acceptable criteria for electronic CAD/D deliverables. Obtaining drawings and ground models in a common format will reduce the amount of time spent becoming familiar with the designs if they are transferred from one designer to another and allows for their reuse in the future.

### FILE FORMAT AND DELIVERY

#### REQUIREMENTS FOR SUBMITTING ELECTRONIC DATA TO NHDOT

All electronic data furnished to the NHDOT shall use the appropriate naming scheme and format for the type of data to be transmitted. It is very important to clearly communicate what is being transmitted and to describe the format of the transmitted files.

A letter is to be attached to **all submissions** stating briefly:

1. File content
2. File Format (zipped, MicroStation, OpenRoads, etc. and the utility used)
3. OpenRoads and/or MicroStation version
4. Number of CDs, DVDs, etc.
5. Files must be in the proper format before transmitting to NHDOT. **No translating of information by NHDOT personnel shall be required.**
6. If files are zipped or backed up, a brief explanation of the recommended procedure to extract the files should be included.
7. Versions of software must be current to or fully compatible with that of the NHDOT.
8. Each disk submitted shall be labeled and dated with a minimum of the State Project # and date. If a series of CDs/DVDs are transmitted, the disk label shall also include the disk number and the total CDs/DVDs of that set, (ex: 1 of 10). Other subsequent CDs/DVDs shall be labeled so as to uniquely identify each group or set and shall include the sequence number followed by the total number in the group (ex: 2 of 10, 3 of 10, etc.)
9. NHDOT reserves the right to reject any file transmitted that does not conform to these requirements.

#### **DATA SUBMISSION**

In addition to hard copy drawings specified by the contract, the consultant shall submit electronic drawing files in MicroStation .DGN file format. Contact the Project Manager for the preferred method for submitting drawing files.

The final submission shall include all files necessary to reproduce the cut sheet drawings as well as copies of the original “roll-plan” drawings used to generate the cut sheets. Documentation of procedures and project history shall be maintained in a Project Journal File. An in-depth description of the Project Journal File is in *PART II – GENERAL CAD/D INFORMATION* beginning on page 7. The Project Journal File will be provided with the submission. Any drawings not included in the NHDOT standard drawing list will be identified and will include a description of levels used on each drawing.

Detailed descriptions of the data to be provided by NHDOT to the consultant and expected deliverables at various stages of the project's development begin on page 40.

If MicroStation tables for linestyles, multilines, level tables, symbology tables, database, special fonts, or any special user defined feature is used, that information must be provided and shall become property of NHDOT. Similarly, any civil design libraries developed by the consultant that are necessary to properly display the project data shall become property of NHDOT. A name and description of each file must also be provided. NHDOT will not distribute these items to any other individual, consultant or State Transportation Department without prior permission of the developer.

#### **INTERMEDIATE SUBMISSIONS**

The consultant shall be prepared to submit sample cut sheet, profile, typical or detail, and/or cross-section sheets for review of conformity to the NHDOT CAD/D specifications at various stages of the project's development. As a minimum, the final design consultant should be prepared to submit electronic project drawings at the Preliminary Plans, Specifications & Estimate (PPS&E) and PS&E stages of the project. Depending on the project, NHDOT may request electronic submissions at a more or less frequent interval.

Since numerous groups work together during the project's design, it is important that everyone uses the same data. Therefore, when changes are made that would affect the design, updated drawings shall be provided to the NHDOT Consultant Reviewer. These, in turn, will be distributed to all affected parties.

#### **DEVIATION FROM FORMAT**

Any file to be submitted that deviates from the above-mentioned DGN format must have prior NHDOT approval. The approval must be in writing with the name of the individual from NHDOT who permitted the varying format.

### **MICROSTATION ONLY DELIVERABLE**

For projects that were initiated after April 18, 2002, NHDOT will only accept plan drawings that were developed in MicroStation's DGN format. Translations from AutoCAD or any other CAD/D software will no longer be allowed on those projects. Projects initiated before that date can continue to follow the requirements in place at the time the project was initiated. Engineering consultants may, at their discretion, choose to follow a subsequent release of these requirements.

### **RECORD OF DESIGN AS SUBMITTED (FINAL DESIGN CONSULTANTS ONLY)**

In addition to MicroStation format drawings, plot files of project cut sheets in PDF format will be required at the completion of the project. Plot files should be named with the convention for plan sheets outlined in *APPENDIX A - MICROSTATION DRAWING NAMES* beginning on page 47 using a .PDF file extension. The purpose of this requirement is to provide a viewable and reproducible copy of the drawing as it existed at the end of the consultant contract.

### **FILE CONVERSION**

**This information only applies to projects initiated prior to April 18, 2002.**

Translation tables, conversion tables, or special software programs have not been created or standardized for exchanging information between common file formats such as DXF, DWG, ICES, IGES, or software such as AutoCAD, ARCVIEW, ARCINFO, GDS, etc.

MicroStation provides methods for exchanging select file types but data is often modified during the process. The Consultant is solely responsible for any translation and verification required to convert non-MicroStation graphics files to the current NHDOT MicroStation design file format. All translated design files shall conform to the standards adopted by NHDOT for electronic plans and the specifications required in this document. Those files shall be converted to MicroStation and thoroughly reviewed prior to transmitting to NHDOT.

## INITIATING A DESIGN PROJECT

This section describes the data that is to be provided to a design consultant at the beginning of a project.

The Plan Preparation section is responsible for taking project survey and preparing the digital terrain model (DTM) and base drawings that will be used during the design process. They should also be the ones to initiate the Project Journal File described in *PART II – GENERAL CAD/D INFORMATION* beginning on page 7.

**By default, NHDOT design teams are working with mostly 2D plan drawings. However, 3D versions of survey detail and contour drawings are also being created. 3D terrain model drawings are being created for use with OpenRoads.**

Electronic data to be provided by the NHDOT Plan Preparation Section to:

Consultants using OpenRoads software:

1. Copy of the 2D and 3D DGN files containing survey data with Plan Preparation modifications/enhancements.
2. 3D terrain model
3. Copy of MicroStation .DGN file containing annotation for survey detail.
4. Copy of the Project Journal File containing all pertinent information about the project.

Consultants without OpenRoads software:

1. LandXML files of existing detail and triangulation generated from the OpenRoads terrain or MX model file
2. Copy of annotated MicroStation .DGN files developed for the project.
3. Copy of the Project Journal File containing all pertinent information about the project.

## INTERIM PROJECT DELIVERABLES

This section describes the data that is to be provided when a project moves from one designer to the next. This could be a transition between Preliminary Design and Final Design consultant designers or a transition between NHDOT designers and consultants. Data received at this point will be provided to the group continuing the design process.

Electronic deliverables expected from NHDOT Highway & Bridge Design staff and Consultants using OpenRoads software:

1. Copy of the 2D and 3D DGN files containing processed survey data and terrain models
2. Copy of any templates necessary to recreate the submitted design
3. Copy of MicroStation .DGN files developed for the project
4. Copy of the Project Journal File containing all pertinent information about the project.
5. Copies of any MicroStation cell files and linestyle resource files used on the project that are not included in the NHDOT standards.

From Consultants without OpenRoads software:

1. LandXML files of existing detail and triangulation generated from the design software
2. Copy of project horizontal and vertical alignments and associated design features in LandXML formats. Descriptions of file transfer formats can be found in APPENDIX E – CIVIL DATA TRANSFER FORMATS beginning on page 53
3. Copy of MicroStation .DGN files developed for the project
4. Copy of the Project Journal File containing all pertinent information about the project.
5. Copies of any MicroStation cell files and linestyle resource files used on the project that are not included in the NHDOT standards.

Electronic data to be provided to the group continuing the design:

Consultants using OpenRoads software:

1. Copy of the 2D and 3D DGN files containing processed survey data and terrain models
2. Copy of OpenRoads design files
3. Copy of any templates necessary to recreate the submitted design
4. Copy of MicroStation .DGN files developed for the project
5. Copy of the Project Journal File containing all pertinent information about the project.
6. Copy of the Project Public Hearing Plan in PDF format

Consultants without OpenRoads software:

1. Copy of project horizontal and vertical alignments and associated design features in LandXML format.
2. LandXML files of existing detail and triangulation generated from the OpenRoads terrain or MX model file.
3. Copy of MicroStation .DGN files developed for the project
4. Copy of the Project Journal File containing all pertinent information about the project.
5. Copy of the Project Public Hearing Plan in PDF format

## **PROJECT COMPLETION**

At the completion of a design project, the following list is a guide to what electronic information is expected to be returned from the design Consultants to NHDOT for final storage. Additional deliverables may be required if 3D design data is to be provided to the construction contractor. In this instance, additional deliverables would be required to comply with Item 670.822 - GNSS Construction Inspection Equipment. Check with the Project Manager for full details.

### **CAD/D FILE INFORMATION**

#### **CAD/D Data in MicroStation DGN Format**

- Copy of MicroStation .DGN files developed for the project

- Include any files from sub-consultants (including Traffic Signals, Ret. Walls, ROW plans, Mitigation sites, Soundwalls, etc...).
- Plotting references needed to re-produce project cut-sheets including sheet numbering (include final project .pcf file, pen-tables, etc...)
- Files used to number the project cut-sheets (project .pcf file, pen tables, etc...).
- Copies of any cell files and linestyle resource files used on the project that are not included in the NHDOT standards.
- Final embellished presentation plan for use by the Construction field office personnel.

#### **Civil Design Data**

- 3D terrain model surfaces (existing and proposed surfaces), triangulation models or dtm surfaces developed by OpenRoads, InRoads, MX or Geopak for use by the Construction Contractor.
- Copy of any templates necessary to recreate the submitted design.
- Copy of any OpenRoads, InRoads, MX or Geopak DGN files used to develop the final contract plan drawings such as drawings containing alignments, profiles, corridors and subsurface utility features.
- If the project was developed using MX, include a copy of the model file and any style/feature sets developed for the project.
- If the project was developed using InRoads, see the additional requirements in *PROJECTS DESIGNED USING INROADS* on page 44.

#### **Spreadsheet Information**

- All project quantity summary sheets in original format (Excel).
- All sign text sheet information in original format (Excel).
- All quantity sheet information in original format (Excel), to be used by Construction staff.
- All drainage note information in original format (Excel, Word, or .dgn), to be used by Construction staff.
- All pollutant loading and related information in original format (Excel, Word, etc...).
- All design spreadsheets used to complete certain design elements (guardrail design, borings, monitoring wells, etc...) in original format (Excel, Word, .dgn, etc...).
- All traffic analyses studies done during the project including any HCM analyses, traffic simulation models, and presentation graphics.
- Any special quantity studies done during the project that could be useful in the future.

#### **Drainage Information**

- All Hydrocad Models in their original format (include index of models in the file).
- All Stormcad, Storm and Sanitary, HY8, Pond Pac, or Hydrain data in their original formats include an index of the numbering sequence of tables).
- All watershed maps in their original format (GIS, .dgn, mapping software, etc...).
- All soil map information that was included in the pollutant loading package.



### **Project Image Files**

The following plans are needed for the Department's plan inventory:

- Provide final .pdf or .tif files of all project final design plan sheets included in the Proposal Prints, in the following format: 12345POPXXXX.pdf where the "12345" is the project number, the XXXX is the sheet number, and POP is the "plan of Proposed", (i.e. 13933GPOP0001.pdf would be the front sheet number 0001 from the 13933G project plans). This format matches the Department's internal naming format for archiving. This includes the Final Roadway plans, Final Bridge plans, etc...
- Provide final .pdf or .tif files of all project plan sheets included in the Proposal Prints, in the following format: 12345ROWXXX.pdf where the "12345" is the project number, the XXX is the sheet number, and ROW is the "Right-Of-Way", (i.e. 13933GROWXXX.pdf would be sheet number XXX from the 13933G project ROW plans). This format matches the Department's internal naming format for archiving. This includes the Final Roadway plans, Final Bridge plans, etc...

The following additional plans are needed for use by the Department:

- Provide the Final Erosion Control Plans in .pdf or .tif files of all project final design erosion control plan sheets in the following format: 12345ECPXXX.pdf where the "12345" is the project number, the XXX is the sheet number, and ECP is the "erosion control plan", (i.e. 13933GECPXXX.pdf would be sheet number XXX from the 13933G project erosion control plans). This format is in keeping with the Department's internal naming format for archiving.
- Provide the Wetland Impact Plans in .pdf or .tif files of all project final design plan sheets in the following format: 12345WETXXX.pdf where the "12345" is the project number, the XXX is the sheet number, and WET is the "wetland impact", (i.e. 13933GWETXXX.pdf would be sheet number XXX from the 13933G project wetland impact plans). This format is in keeping with the Department's internal naming format for archiving. Roll plan .pdf files may also be required depending on project specific's (including scale and layout).
- Provide the Shoreland Impact Plans in .pdf or .tif files of all project final design plan sheets in the following format: 12345SHOXXX.pdf where the "12345" is the project number, the XXX is the sheet number, and SHO is the "Shoreland impact", (i.e. 13933GSHOXXX.pdf would be sheet number XXX from the 13933G project Shoreland impact plans). This format is in keeping with the Department's internal naming.
- Final embellished presentation roll plan for use by the Construction field office personnel in .pdf form.

### **Project Photographs**

- Provide electronic versions of all photograph's taken during design of the project. This would include any photo's used in the Wetland Impact and Shoreland Impact application process.

### **Project Journal File**

- Care shall be taken to prepare a complete Project Journal File outlining all files and descriptions used on the project. In addition to the cut-sheet definitions, all cut sheet models need to be included so the sheets can be re-produced.

### Text Files

- COGO and coordinate reports of each alignment similar in format to the ones shown in *APPENDIX F – CONSTRUCTION REPORTS* on page 55 for use by NHDOT Survey section and the Construction Contractor.
- Station and offset listing of proposed bounds.
- Complete index of all 3D model surfaces provided and what they are used for.
- Any information necessary to properly plot the drawings. Include any pen-tables used in the project.

### Additional Data

- Additional deliverables may be required if 3D design data is to be provided to the construction contractor. In this instance, additional deliverables would be required to comply with Item 670.822 - GNSS Construction Inspection Equipment. Check with the Project Manager for full details.

### PROJECTS DESIGNED USING INROADS

If a project is designed with InRoads the following files should be delivered as part of the electronic deliverable:

InRoads Preferences (\*.xin): This file will contain the settings used to control the display of information as well as the default values displayed in InRoads dialogs for generating the design graphics.

Surface data: (\*.dtm): These files will contain existing and proposed surface information. This information will include but is not limited to the surface triangulation. Other information that will potentially be found in the DTM include planimetric features like: breaklines representing existing and proposed objects, feature lines for entities like R.O.W. or easements, as well as random point information that can depict features like catch basins, mailboxes, or other single point features.

Alignment data (alg): This will contain all coordinate geometry and alignment information for the project alignments.

Template Library file (\*.itl): Contains the templates (Typical sections), cut and fill tables, material tables, decision tables and transition control features. This is one of the building blocks used in Roadway Designer.

Roadway designer files (\*.ird): The roadway designer file will include the templates (Typical sections) in addition to the roadway model definition, this is the “recipe” to build your design. Items in this file include: superelevation, links to the alignments used in the design, as well as the limits of design.

Survey data (\*.fwd or other formats): If the survey for the project was completed by people outside the department, then all data used to create the existing conditions plans should be

provided. If the survey was done in InRoads Survey, then the .fwd files that were imported into InRoads Survey should be provided. If the survey was prepared with a different software, then the data brought into InRoads should be provided in its original format.

Style Sheets (\*.xsl): InRoads report style sheets used for reports included in the design should also be delivered with the project.

Storm & Sanitary files (\*.sdb): The design information entered into InRoads Storm & Sanitary should also be included for the Department's use. This will include location, sizes and structure types for the drainage design.

Quantity Manager files (\*.mdb): This file is the database containing the automatically generated quantities from InRoads for the project.

#### **SPECIALIZED DEVELOPMENT BY DESIGN CONSULTANTS**

Any specialized programs, macros, utilities, symbology, etc., developed by the consultant that are necessary to properly display drawings submitted to NHDOT shall be included with other project deliverables.

Submission of copies of other specialized programs, macros, utilities, symbology, etc. developed to improve the CAD/D drafting and design processes is encouraged. It is understood that NHDOT accepts these items without any guarantee of usefulness or expectations of support by the developer. In addition, NHDOT will not distribute these items to any other individual, consultant or State Transportation Department without prior permission of the developer.

### **NHDOT RESOURCES AVAILABLE FOR CONSULTANTS**

To assist in the production of the required CAD/D files, NHDOT has provided MX and MicroStation support files available from the Department's web site. The website address is listed in the *DOCUMENTATION* section on page 7. Many of the files that are available are described in the *LEVEL ASSIGNMENTS AND SYMBOLOGY* section on page 15.



## **PART VIII - APPENDIX**

### **APPENDIX A - MICROSTATION DRAWING NAMES**

**Note:** MicroStation drawing information was included in previous editions of this document. To reduce the potential for errors and conflicting data, this information has been removed. The current list of drawing names can be found in the MicroStation section of the CAD/D website at the address listed in the *DISCLAIMER* section of this document.

### **APPENDIX B - LEVEL MAPPING CONVENTION**

**Note:** MicroStation level information was included in previous editions of this document. To reduce the potential for errors and conflicting data, this information has been removed. The latest mapping convention can be found on the NHDOT web-site at the address listed in the *DISCLAIMER* section of this document. Previous versions of the level mapping will be maintained on the website.



## APPENDIX C - NHDOT CUSTOM LINSTYLES & FONT

|  |   |
|--|---|
| <p>————— 0</p> <p>..... 1</p> <p>----- 2</p> <p>----- 3</p> <p>----- 4</p> <p>----- 5</p> <p>----- 6</p> <p>----- 7</p> <p>————— ( Border )</p> <p>————— ( Center )</p> <p>----- ( Dashdot )</p> <p>----- ( Dashed )</p> <p>----- ( Divide )</p> <p>----- ( Dot )</p> <p>----- ( Hidden )</p> <p>----- ( Phantom )</p> <p>————— ArBegOpn</p> <p>————— ArBegSlid</p> <p>————— ArEndOpn</p> <p>————— ArEndSlid</p> <p>————— Arrow</p> <p>————— Arrow2</p> <p>————— ArrowBr</p> <p>~~~~~ Berm</p> <p>----- BmGrDbI</p> <p>----- BmGrLt</p> <p>----- BmGrRt</p> <p>----- BmGrSpExLt</p> <p>----- BmGrSpExRt</p> <p>----- BmGrSpPrLt</p> <p>----- BmGrSpPrRt</p> <p>----- Break</p> <p>----- BreakBr</p> <p>----- BreakDimBr</p> <p>~~~~~ Bush</p> <p>----- CATV</p> <p>----- CbIGrLt</p> <p>----- CbIGrMed</p> <p>----- CbIGrRt</p> <p>----- ConduitL</p> <p>----- ConduitL-Prop</p> <p>----- Conduits</p> <p>----- PC-Conduits-Prop</p> <p>----- Continuous</p> <p>----- County</p> <p>----- CurbLt</p> <p>----- CurbRt</p> <p>----- CutLt</p> <p>----- CutRt</p> <p>----- DFL_P</p> <p>----- Dim2</p> <p>----- DimBr</p> <p>----- Ditch</p> <p>===== DrainPipe</p> <p>===== DrainPipe-Prop</p> | <p>----- CDL ----- E-CDL</p> <p>----- DTBZ ----- E-DTBZ</p> <p>----- LC ----- E-LC</p> <p>----- MHW ----- E-MHW</p> <p>----- MLW ----- E-MLW</p> <p>----- NHW ----- E-NHW</p> <p>----- NJDA ----- E-NJDA</p> <p>----- PWET100 ----- E-PWET100</p> <p>----- WBF ----- E-WBF</p> <p>----- ERCP</p> <p>----- ERCPL</p> <p>----- ERCWB</p> <p>----- ERCWBL</p> <p>----- ERNBPC</p> <p>----- ERPC</p> <p>----- Electric-Exist</p> <p>----- Electric-DH</p> <p>----- Electric-Prop</p> <p>----- FP100</p> <p>----- FP500</p> <p>----- FW</p> <p>----- Fence-Barbed</p> <p>----- Fence-Barbed(short)</p> <p>----- Fence-Noarb</p> <p>----- Fence-Noarb(short)</p> <p>----- FiberOptic-Exist</p> <p>----- FiberOptic-Prop</p> <p>----- Fill</p> <p>----- Fire-Exist</p> <p>----- Fire-Prop</p> <p>----- GR-BlockoutLt</p> <p>----- GR-BlockoutRt</p> <p>----- GR-SteelPostLt</p> <p>----- GR-SteelPostRt</p> <p>----- Gas-Exist</p> <p>----- Gas-Prop</p> <p>----- Ground-Exist</p> |
|--|---|

|  |               |  |                 |
|--|---------------|--|-----------------|
|  | GroundBr      |  | PipeP12         |
|  | HOTL          |  | PipeP15         |
|  | Hedge         |  | PipeP18         |
|  | INV           |  | PipeP24         |
|  | ITS-Exist     |  | PipeP30         |
|  | ITS-Prop      |  | PipeP36         |
|  | JerseyBarrier |  | PipeP42         |
|  | LABL          |  | PipeP48         |
|  | LTRD          |  | PipeP54         |
|  | Leader        |  | PipeP60         |
|  | Leader2       |  | PipeP66         |
|  | LeaderBr      |  | PipeP72         |
|  | Ledge         |  | PipeP84         |
|  | LedgeBr       |  | PipeP96         |
|  | Light-Exist   |  | PropLine        |
|  | Light-Prop    |  | QML             |
|  | MHT           |  | REF             |
|  | MJCY          |  | RG              |
|  | MJS           |  | RDW             |
|  | MagDet        |  | RRPSS           |
|  | NWB150        |  | RRRow           |
|  | NtnlForest    |  | Railroad        |
|  | OHT           |  | RetWallLt       |
|  | OHW           |  | RetWallRt       |
|  | Overhead-Wire |  | RockRt          |
|  | PCurbLt       |  | RockLine        |
|  | PCurbRt       |  | RocklineBr      |
|  | PS250         |  | SAS             |
|  | PWET          |  | Sewer-Exist     |
|  | PaveMark      |  | Sewer-Prop      |
|  | PedRail       |  | SheetPile       |
|  | PipeE12       |  | StateLine       |
|  | PipeE15       |  | Steam-Exist     |
|  | PipeE18       |  | Steam-Prop      |
|  | PipeE24       |  | StoneFill       |
|  | PipeE30       |  | StoneWall-Exist |
|  | PipeE36       |  | StoneWall-Prop  |
|  | PipeE42       |  | StoneWall-Short |
|  | PipeE48       |  | StreamLt        |
|  | PipeE54       |  | StreamRt        |
|  | PipeE60       |  | TBZ             |
|  | PipeE66       |  | TDB             |
|  | PipeE72       |  | TOB             |
|  | PipeE84       |  | TOBOW           |
|  | PipeE96       |  |                 |



|  |                 |             |  |                       |
|--|-----------------|-------------|--|-----------------------|
|  | T               | Tele-Exist  |  | XP1pP42               |
|  | PT              | Tele-Prop   |  | XP1pP48               |
|  | Tick            |             |  | XP1pP54               |
|  | TownLine        |             |  | XP1pP60               |
|  | TrafBarIs       |             |  | XP1pP66               |
|  | UE              |             |  | XP1pP72               |
|  | UEH             |             |  | XP1pP84               |
|  | UT              |             |  | XP1pP96               |
|  | UTH             |             |  | XUnderDrain           |
|  | UTV             |             |  | XUnderDrain-Prop      |
|  | UnderDrain      |             |  | ZPropLine             |
|  | UnderDrain-Prop |             |  | { -E- }               |
|  | VP              | VP          |  | { Arrow }             |
|  | WB50            | WB50        |  | { Batten }            |
|  | W               | Water-Exist |  | { Cable / Tele }      |
|  | PW              | Water-Prop  |  | { Chain Double-Dash } |
|  | DW              | Wetland     |  | { Curtain }           |
|  | WoodsLt         |             |  | { Dashed Triple-Dot } |
|  | WoodsRt         |             |  | { Diamond }           |
|  | XP1pE12         |             |  | { Gas Line }          |
|  | XP1pE15         |             |  | { Ground Line }       |
|  | XP1pE18         |             |  | { Half Dash }         |
|  | XP1pE24         |             |  | { Leader Line }       |
|  | XP1pE30         |             |  | { Offset Lines }      |
|  | XP1pE36         |             |  | { Origin Line }       |
|  | XP1pE42         |             |  | { Rail Road }         |
|  | XP1pE48         |             |  | { Tapered Dash }      |
|  | XP1pE54         |             |  | { Tree Line }         |
|  | XP1pE60         |             |  | { Wide Dash }         |
|  | XP1pE66         |             |  |                       |
|  | XP1pE72         |             |  |                       |
|  | XP1pE84         |             |  |                       |
|  | XP1pE96         |             |  |                       |
|  | XP1pP12         |             |  |                       |
|  | XP1pP15         |             |  |                       |
|  | XP1pP18         |             |  |                       |
|  | XP1pP24         |             |  |                       |
|  | XP1pP30         |             |  |                       |
|  | XP1pP36         |             |  |                       |

nh\_engineering (Font 180) Special Characters

|                    |                |                       |                          |                     |
|--------------------|----------------|-----------------------|--------------------------|---------------------|
| 035 = #            | 082 = R        | 129 = $\frac{1}{2}$   | 176 = $\frac{33}{64}$    | 223 = $\cap$        |
| 036 = \$           | 083 = S        | 130 = $\frac{1}{4}$   | 177 = $\frac{35}{64}$    | 224 = $\cup$        |
| 037 = %            | 084 = T        | 131 = $\frac{3}{4}$   | 178 = $\frac{37}{64}$    | 225 = $\sqcap$      |
| 038 = &            | 085 = U        | 132 = $\frac{1}{8}$   | 179 = $\frac{39}{64}$    | 226 = $\sqcup$      |
| 039 = '            | 086 = V        | 133 = $\frac{3}{8}$   | 180 = $\frac{41}{64}$    | 227 =               |
| 040 = (            | 087 = W        | 134 = $\frac{5}{8}$   | 181 = $\frac{43}{64}$    | 228 =               |
| 041 = )            | 088 = X        | 135 = $\frac{7}{8}$   | 182 = $\frac{45}{64}$    | 229 = $\sqcup$      |
| 042 = *            | 089 = Y        | 136 = $\frac{1}{16}$  | 183 = $\frac{47}{64}$    | 230 = $\sqcap$      |
| 043 = +            | 090 = Z        | 137 = $\frac{3}{16}$  | 184 = $\frac{49}{64}$    | 231 = $\sqcup$      |
| 044 = ,            | 091 = [        | 138 = $\frac{5}{16}$  | 185 = $\frac{51}{64}$    | 232 = $\sqcap$      |
| 045 = -            | 092 = $\leq$   | 139 = $\frac{7}{16}$  | 186 = $\frac{53}{64}$    | 233 = $\sqcup$      |
| 046 = .            | 093 = ]        | 140 = $\frac{9}{16}$  | 187 = $\frac{55}{64}$    | 234 = $\sqcap$      |
| 047 = /            | 094 = °        | 141 = $\frac{11}{16}$ | 188 = $\frac{57}{64}$    | 235 = $\sqcup$      |
| 048 = 0            | 095 = _        | 142 = $\frac{13}{16}$ | 189 = $\frac{59}{64}$    | 236 = $\square$     |
| 049 = 1            | 096 = $\angle$ | 143 = $\frac{15}{16}$ | 190 = $\frac{61}{64}$    | 237 = $\square$     |
| 050 = 2            | 097 = a        | 144 = $\frac{1}{32}$  | 191 = $\frac{63}{64}$    | 238 = $\circ$       |
| 051 = 3            | 098 = b        | 145 = $\frac{3}{32}$  | 192 = $\mathbb{C}$       | 239 =               |
| 052 = 4            | 099 = c        | 146 = $\frac{5}{32}$  | 193 = $\mathbb{R}$       | 240 = $\square$     |
| 053 = 5            | 100 = d        | 147 = $\frac{7}{32}$  | 194 = $\emptyset$        | 241 = $\rightarrow$ |
| 054 = 6            | 101 = e        | 148 = $\frac{9}{32}$  | 195 = $\mathbb{N}$       | 242 = $\rightarrow$ |
| 055 = 7            | 102 = f        | 149 = $\frac{11}{32}$ | 196 = $\mathbb{Q}$       | 243 = $\rightarrow$ |
| 056 = 8            | 103 = g        | 150 = $\frac{13}{32}$ | 197 = $\mathbb{E}$       | 244 = $\checkmark$  |
| 057 = 9            | 104 = h        | 151 = $\frac{15}{32}$ | 198 = $\mathbb{G}$       | 245 = *             |
| 058 = :            | 105 = i        | 152 = $\frac{17}{32}$ | 199 = $\Delta$           | 246 = $Q_{10}$      |
| 059 = ;            | 106 = j        | 153 = $\frac{19}{32}$ | 200 = $\pm$              | 247 = $Q_{25}$      |
| 060 =              | 107 = k        | 154 = $\frac{21}{32}$ | 201 =                    | 248 = $Q_{50}$      |
| 061 = =            | 108 = l        | 155 = $\frac{23}{32}$ | 202 = $\subset$          | 249 = $Q_{100}$     |
| 062 = $\mathbb{C}$ | 109 = m        | 156 = $\frac{25}{32}$ | 203 = $\supset$          | 250 = $\emptyset$   |
| 063 = ?            | 110 = n        | 157 = $\frac{27}{32}$ | 204 = $\sqsubset$        | 251 = $f_6$         |
| 064 = @            | 111 = o        | 158 = $\frac{29}{32}$ | 205 = $\sqsupset$        | 252 = $^2$          |
| 065 = A            | 112 = p        | 159 = $\frac{31}{32}$ | 206 = $\downarrow$       | 253 = $^3$          |
| 066 = B            | 113 = q        | 160 = $\frac{1}{64}$  | 207 = $\angle$           | 254 =               |
| 067 = C            | 114 = r        | 161 = $\frac{3}{64}$  | 208 = $\downarrow$       | 255 = 7             |
| 068 = D            | 115 = s        | 162 = $\frac{5}{64}$  | 209 = $\angle$           |                     |
| 069 = E            | 116 = t        | 163 = $\frac{7}{64}$  | 210 = $\downarrow$       |                     |
| 070 = F            | 117 = u        | 164 = $\frac{9}{64}$  | 211 = $\angle$           |                     |
| 071 = G            | 118 = v        | 165 = $\frac{11}{64}$ | 212 = $\angle$           |                     |
| 072 = H            | 119 = w        | 166 = $\frac{13}{64}$ | 213 = $\downarrow$       |                     |
| 073 = I            | 120 = x        | 167 = $\frac{15}{64}$ | 214 = $\angle$           |                     |
| 074 = J            | 121 = y        | 168 = $\frac{17}{64}$ | 215 =                    |                     |
| 075 = K            | 122 = z        | 169 = $\frac{19}{64}$ | 216 = $\subset$          |                     |
| 076 = L            | 123 = {        | 170 = $\frac{21}{64}$ | 217 = $\supset$          |                     |
| 077 = M            | 124 = $\geq$   | 171 = $\frac{23}{64}$ | 218 = $\curvearrowright$ |                     |
| 078 = N            | 125 = }        | 172 = $\frac{25}{64}$ | 219 = $\curvearrowleft$  |                     |
| 079 = O            | 126 = $\angle$ | 173 = $\frac{27}{64}$ | 220 = $\sqcap$           |                     |
| 080 = P            | 127 = $<$      | 174 = $\frac{29}{64}$ | 221 = $\sqcap$           |                     |
| 081 = Q            | 128 = $>$      | 175 = $\frac{31}{64}$ | 222 = $\cap$             |                     |

Character 245 is used in dimensions where a character appearing as an \* is needed. The normal \* will show the dimension value.

## **APPENDIX D – MX MODEL NAMING CONVENTION**

NHDOT is transitioning from MX to OpenRoads for Civil Design work. As a result, this section has been retired. For information on the MX Model Naming Convention, please visit the NHDOT CAD/D website at the address listed in the *DISCLAIMER* section of this document.

## **APPENDIX E – CIVIL DATA TRANSFER FORMATS**

### **LANDXML**

The use of LandXML is encouraged for transferring design data. LandXML was established to exchange design data utilizing a non-proprietary data standard. LandXML is the easiest avenue for transferring alignments between design softwares, including (but not limited to) OpenRoads, MX, InRoads, and Geopak.

Survey data and surface triangulations may also be transferred via LandXML. However at this time, there are still limitations when transferring large models (surfaces). Therefore, it is strongly recommended to translate only essential data.

Importing LandXML data to OpenRoads and exporting OpenRoads data to LandXML are documented on the Department's web site. Also, learn more about LandXML at [www.LandXML.org](http://www.LandXML.org).



## APPENDIX F – CONSTRUCTION REPORTS

**SAMPLE OPENROADS ALIGNMENT REPORT (COGO STYLE)**

### Horizontal Alignment Review Report

Report Created: 4/7/2017 3:20pm

**Project:** Unity 20262  
**Description:**  
**File Name:** \Unity\20262\OpenRoads\FinalDesign\20262geometry.dgn  
**Last Revised:** 4/7/2017 15:20:37  
**Note:** All units in this report are in feet unless specified otherwise.

Alignment Name: MC1M  
 Alignment Description:  
 Alignment Style: Alignment

|                       |                 | Station    | Northing    | Easting      |
|-----------------------|-----------------|------------|-------------|--------------|
| Element: Linear       |                 |            |             |              |
| POB                   | ( )             | 506+00.000 | 473216.5314 | 1112416.8044 |
| PC                    | ( )             | 518+98.666 | 474501.7220 | 1112603.3988 |
| Tangential Direction: | N 8°15'39.39" E |            |             |              |
| Tangential Length:    | 1298.6655       |            |             |              |

|                            |                   |            |             |              |
|----------------------------|-------------------|------------|-------------|--------------|
| Element: Circular          |                   |            |             |              |
| PC                         | ( )               | 518+98.666 | 474501.7220 | 1112603.3988 |
| PI                         | ( )               | 523+15.352 | 474913.6842 | 1112665.9685 |
| CC                         | ( )               |            | 474680.4163 | 1111426.8662 |
| PT                         | ( )               | 527+00.285 | 475274.6939 | 1112457.8825 |
| Radius:                    | 1190.0255         |            |             |              |
| Delta:                     | 38°35'43.23" Left |            |             |              |
| Degree of Curvature (Arc): | 15°47'46.16"      |            |             |              |
| Length:                    | 801.6199          |            |             |              |

|                    |                  |
|--------------------|------------------|
| Tangent:           | 416.6867         |
| Chord:             | 786.5498         |
| Middle Ordinate:   | 66.8623          |
| External:          | 70.8426          |
| Tangent Direction: | N 8°38'10.33" E  |
| Radial Direction:  | S 81°21'49.67" E |
| Chord Direction:   | N 10°39'41.29" W |
| Radial Direction:  | N 60°02'27.10" E |
| Tangent Direction: | N 29°57'32.90" W |

|                       |                  |            |             |              |
|-----------------------|------------------|------------|-------------|--------------|
| Element: Linear       |                  |            |             |              |
| PT                    | ( )              | 527+00.285 | 475274.6939 | 1112457.8825 |
| PI                    | ( )              | 551+97.003 | 477341.3433 | 1111056.9681 |
| Tangential Direction: | N 34°07'55.45" W |            |             |              |
| Tangential Length:    | 2496.7180        |            |             |              |

|                       |                  |            |             |              |
|-----------------------|------------------|------------|-------------|--------------|
| Element: Linear       |                  |            |             |              |
| PI                    | ( )              | 551+97.003 | 477341.3433 | 1111056.9681 |
| POE                   | ( )              | 552+02.003 | 477338.4029 | 1111052.9241 |
| Tangential Direction: | S 53°58'46.85" W |            |             |              |
| Tangential Length:    | 5.0000           |            |             |              |

**SAMPLE OPENROADS ALIGNMENT REPORT (COORDINATES)**

**Horizontal Elements XYZ Report**

Report Created: 4/7/2017 3:20pm

**Project:** Unity 20262  
**Description:**  
**File Name:** \Unity\20262\OpenRoads\FinalDesign\20262geometry.dgn  
**Last Revised:** 4/7/2017 15:20:37  
**Note:** All units in this report are in feet unless specified otherwise.

| Alignment Name: |              | MC1          |           |            |                  |            |  |
|-----------------|--------------|--------------|-----------|------------|------------------|------------|--|
| Point           | Easting (X)  | Northing (Y) | Elevation | Station    | Direction        | Radius     |  |
| 1               | 1112416.8044 | 473216.5314  | 0.00      | 506+00.000 | N 8°15'39.39" E  |            |  |
| 10              | 1112423.9885 | 473266.0126  | 0.00      | 506+50.000 | N 8°15'39.39" E  |            |  |
| 11              | 1112431.1725 | 473315.4938  | 0.00      | 507+00.000 | N 8°15'39.39" E  |            |  |
| 12              | 1112438.3566 | 473364.9750  | 0.00      | 507+50.000 | N 8°15'39.39" E  |            |  |
| 13              | 1112445.5407 | 473414.4562  | 0.00      | 508+00.000 | N 8°15'39.39" E  |            |  |
| 14              | 1112452.7248 | 473463.9374  | 0.00      | 508+50.000 | N 8°15'39.39" E  |            |  |
| 15              | 1112459.9089 | 473513.4186  | 0.00      | 509+00.000 | N 8°15'39.39" E  |            |  |
| 16              | 1112467.0930 | 473562.8998  | 0.00      | 509+50.000 | N 8°15'39.39" E  |            |  |
| 17              | 1112474.2770 | 473612.3810  | 0.00      | 510+00.000 | N 8°15'39.39" E  |            |  |
| 18              | 1112481.4611 | 473661.8622  | 0.00      | 510+50.000 | N 8°15'39.39" E  |            |  |
| 19              | 1112488.6452 | 473711.3434  | 0.00      | 511+00.000 | N 8°15'39.39" E  |            |  |
| 20              | 1112495.8293 | 473760.8246  | 0.00      | 511+50.000 | N 8°15'39.39" E  |            |  |
| 21              | 1112503.0134 | 473810.3058  | 0.00      | 512+00.000 | N 8°15'39.39" E  |            |  |
| 22              | 1112510.1974 | 473859.7870  | 0.00      | 512+50.000 | N 8°15'39.39" E  |            |  |
| 23              | 1112517.3815 | 473909.2682  | 0.00      | 513+00.000 | N 8°15'39.39" E  |            |  |
| 24              | 1112524.5656 | 473958.7494  | 0.00      | 513+50.000 | N 8°15'39.39" E  |            |  |
| 25              | 1112531.7497 | 474008.2306  | 0.00      | 514+00.000 | N 8°15'39.39" E  |            |  |
| 26              | 1112538.9338 | 474057.7118  | 0.00      | 514+50.000 | N 8°15'39.39" E  |            |  |
| 27              | 1112546.1178 | 474107.1930  | 0.00      | 515+00.000 | N 8°15'39.39" E  |            |  |
| 28              | 1112553.3019 | 474156.6742  | 0.00      | 515+50.000 | N 8°15'39.39" E  |            |  |
| 29              | 1112560.4860 | 474206.1554  | 0.00      | 516+00.000 | N 8°15'39.39" E  |            |  |
| 30              | 1112567.6701 | 474255.6366  | 0.00      | 516+50.000 | N 8°15'39.39" E  |            |  |
| 31              | 1112574.8542 | 474305.1178  | 0.00      | 517+00.000 | N 8°15'39.39" E  |            |  |
| 32              | 1112582.0383 | 474354.5990  | 0.00      | 517+50.000 | N 8°15'39.39" E  |            |  |
| 33              | 1112589.2223 | 474404.0802  | 0.00      | 518+00.000 | N 8°15'39.39" E  |            |  |
| 34              | 1112596.4064 | 474453.5614  | 0.00      | 518+50.000 | N 8°15'39.39" E  |            |  |
| 2               | 1112603.3988 | 474501.7220  | 0.00      | 518+98.666 | N 8°15'39.39" E  |            |  |
| 3               | 1112603.3988 | 474501.7220  | 0.00      | 518+98.666 | N 8°38'10.33" E  | -1190.0255 |  |
| 35              | 1112603.5984 | 474503.0414  | 0.00      | 519+00.000 | N 8°34'19.03" E  | -1190.0255 |  |
| 36              | 1112610.0103 | 474552.6249  | 0.00      | 519+50.000 | N 6°09'52.62" E  | -1190.0255 |  |
| 37              | 1112614.3338 | 474602.4339  | 0.00      | 520+00.000 | N 3°45'26.22" E  | -1190.0255 |  |
| 38              | 1112616.5613 | 474652.3806  | 0.00      | 520+50.000 | N 1°20'59.82" E  | -1190.0255 |  |
| 39              | 1112616.6890 | 474702.3768  | 0.00      | 521+00.000 | N 1°03'26.58" W  | -1190.0255 |  |
| 40              | 1112614.7165 | 474752.3342  | 0.00      | 521+50.000 | N 3°27'52.99" W  | -1190.0255 |  |
| 41              | 1112610.6474 | 474802.1646  | 0.00      | 522+00.000 | N 5°52'19.39" W  | -1190.0255 |  |
| 42              | 1112604.4888 | 474851.7802  | 0.00      | 522+50.000 | N 8°16'45.79" W  | -1190.0255 |  |
| 43              | 1112596.2516 | 474901.0933  | 0.00      | 523+00.000 | N 10°41'12.20" W | -1190.0255 |  |
| 44              | 1112585.9503 | 474950.0168  | 0.00      | 523+50.000 | N 13°05'38.60" W | -1190.0255 |  |

## APPENDIX G – CROSS SECTION SET LABELS

**Note:** MX cross-section label information was included in previous editions of this document. To reduce the potential for errors and conflicting data, this information has been removed. The current list of cross-section information can be found in the MX section of the CAD/D website at the address listed in the *DISCLAIMER* section of this document.